



GEZE SLIDING DOOR SYSTEMS
VERSATILE AND COMFORTABLE



TABLE OF CONTENTS

Overview table	4
Standard sliding door systems	5
GEZE ECdrive	7
GEZE Slimdrive SL NT	18
GEZE Powerdrive PL	28
Special versions of sliding door systems	37
GEZE Slimdrive SLT	38
GEZE Slimdrive SL RC2	47
GEZE Slimdrive SL-BO	52
GEZE Slimdrive SL-RD	54
GEZE Slimdrive SF	56
GEZE Slimdrive SL-T30	61
GEZE Slimdrive SLV	62
GEZE Slimdrive SL inclined	63
Special functions for escape and rescue routes	
Redundant sliding doors for escape and rescue routes with locked shop closing function (FR-LL)	64
Redundant sliding doors for escape and rescue routes in both directions (FR-DUO)	65
Redundant sliding doors for locked escape and rescue routes (FR-RWS)	66
Sliding doors for escape and rescue routes according to CO48 (France)	67
Functions and solutions	
Accessible toilet	68
Vestibule systems	69
Sliding door fittings	70
Accessories	
Operating automatic sliding doors	72
Automatic activation	73
Manual activation	74
Electronic protection	75
Locks	76
Service tools	78
Cable diagram	79
References	80

GEZE SLIDING DOOR SYSTEMS

Overview table for automatic sliding door systems

	ECdrive	Slimdrive SL NT	Powerdrive PL	Page
Product features				
Dimensions (height x depth)	120 x 175 mm 150 x 175 mm	70 x 190 mm	150 x 185 mm 200 x 185 mm	
Opening width 1-leaf	700 - 3000 mm	700 - 3000 mm	700 - 3000 mm	
Opening width 2-leaf	900 - 3000 mm	900 - 3000 mm	800 - 3000 mm	
Leaf weight (max.) 1-leaf	120 kg	125 kg	200 ¹ kg	
Leaf weight (max.) 2-leaf	2 x 120 kg	2 x 125 kg	2 x 180 ¹ kg 2 x 200 ² kg	
Opening / closing speed (max.)	0.8 / 0.8 m/s	0.8 / 0.8 m/s	0.8 / 0.8 m/s	
Redundant sliding doors for escape and rescue routes (FR)	•	•	•	6
Special functions for escape and rescue routes				
FR with locked shop closing (FR-LL)	•	•	•	64
FR in both directions (FR-DUO)	•	•	•	65
FR locked (FR-RWS)	•	•	•	66
CO48 (France)	•	•	•	67
Fittings				
ISO glass fine-framed	•	•	•	
MONO glass fine-framed	•	•	•	
ESG clamping profile fine-framed	•		•	
All-glass system (GGS)		•		
Integrated all-glass system (IGG)		•		
Stainless steel			•	
On-site leaves	•	•	•	
Page	7	18	28	

• = Yes

¹ = max. 160 kg for FR version, max. 120 kg for fine-framed leaves

² = increased opening and hold-open times if nec.

STANDARD SLIDING DOOR SYSTEMS

Standard sliding door systems

For comfort and perfection

Sliding doors are space-saving, elegant and modern. Glass sliding doors are ideal when it comes to making good use of daylight and fulfilling optical criteria. GEZE automatic sliding doors can be used to realise various user scenarios in one building.

- The variants of the **Slimdrive** series with an overall height of only seven centimetres blend perfectly into any building's architecture and offer a wide range of application possibilities.
- **ECdrive** drives are economical and extremely reliable in their functionality.
- **Powerdrive** drives are real power packages and capable of moving heavy doors conveniently and safely.



Augustinum, Stuttgart, Germany (photo: Dirk Wilhelmy)

Area of application

- Public buildings and authorities
- Businesses and car dealerships
- Shopping centres and retail
- Airports and railway stations
- Health and care sector, e.g. hospitals, pharmacies
- Hotels and gastronomy
- Banks and education institutes e.g. schools, universities
- Industrial buildings
- Vestibule systems

DIN 18650

The industrial standard DIN 18650 was created to guarantee operators and users of automatic doors optimum safety. GEZE sliding door systems have been type-tested and certified in accordance with DIN 18650.

EN 16005

The new European standard EN 16005 sets out the design requirements and testing methods used to ensure the safe use of automatic doors. The new standard has created a Europe-wide safety standard for automatic doors.

All automatic door systems and safety sensors from GEZE meet the EN 16005 standard and are available.

STANDARD SLIDING DOOR SYSTEMS

Redundant sliding doors for escape and rescue routes (FR)

To guarantee the safety of escape and rescue routes, the control unit is designed in a redundant way in connection with the complete system. This redundancy guarantees that in the event of a power failure or fault, the sliding door will automatically open safely in the modes of operation „Automatic“ and „Shop closing“. In „Night“ mode of operation the lock prevents unauthorised opening of the door. There is no escape and rescue route function in this mode of operation.



Kolbenschmidt Pierburg, Neckarsulm, Germany (photo: Nikolaus Grünwald)

Design possibilities with the sliding door system



- 1 = Sliding door drive
- 2 = Moving leaf
- 3 = Side part
- 4 = Combined detector
- 5 = Active infrared light curtain
- 6 = Programme switch with key switch

- 7 = Plastic elbow switch
- 8 = Glass LED sensor push button
- 9 = Proximity switch
- 10 = Elbow switch
- 11 = Foot contact switch
- 12 = Photoelectric barriers

GEZE ECdrive

Drive system for linear sliding doors in high traffic areas

The linear sliding door system GEZE ECdrive offers numerous convincing benefits at an excellent cost/performance ratio. The drive is suitable for doors in high traffic areas. The ECdrive covers door leaf weights of up to 120 kg and is uncompromisingly reliable. High-quality materials and the latest control technology guarantee high efficiency. Servicing costs are considerably reduced thanks to the self-cleaning roller carriage. The rounded cover in the elegant GEZE design gives the system an attractive appearance.



Technical data

Product features	ECdrive	ECdrive FR
For 1-leaf door systems	•	•
For 2-leaf door systems	•	•
Height	120 / 150 mm	
Depth	175 mm	
Leaf weight (max.) 1-leaf	120 kg	
Leaf weight (max.) 2-leaf	120 kg	
Opening width 1-leaf	700 – 3000 mm	
Opening width 2-leaf	900 – 3000 mm	
Temperature range	-15 – 50 °C	
IP rating	IP20	
Disconnection from mains	Main switch in the drive	
Opening speed (max.)	0.8 m/s	
Closing speed (max.)	0.8 m/s	
Hold-open time	0 – 60 S	
Adjustable opening and closing force (max.)	150 N	
Automatic adaptation to traffic flow	•	•
Automatic reversal when an obstacle is detected	•	•
Pharmacy opening	•	•
Interlocking door system function	•	-
Vestibule function	•	-
Automatic opening in the event of a power failure	adjustable	fitted as standard
Automatic closing in the event of a power failure	adjustable	not available
Function in the event of a power failure	adjustable for 30 min. / 30 cycles	open
Automatic opening in the event of a fault	not available	fitted as standard
Approvals	DIN 18650 BGR232 DIN EN ISO 13849: Performance Level D	DIN 18650 BGR232 DIN EN ISO 13849: Performance Level D AutSchR

- = YES
- = NOT AVAILABLE

GEZE ECdrive

Drive components

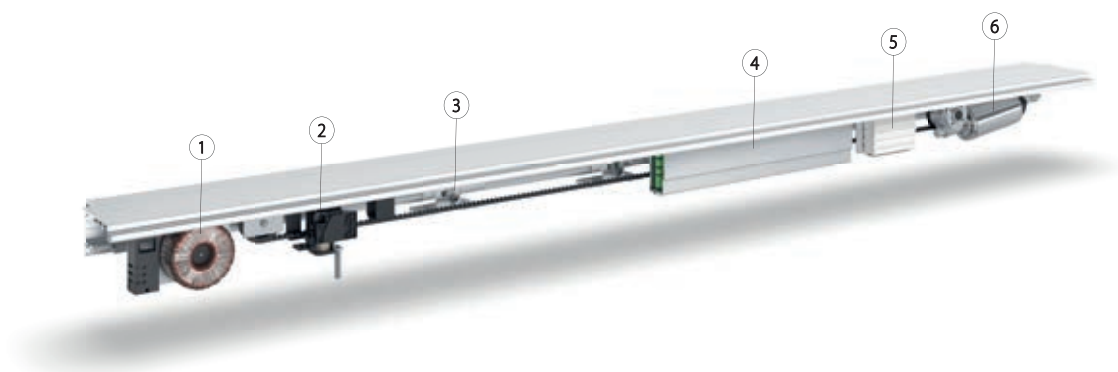

- 1 = Transformer
- 2 = Lock
- 3 = Roller carriage
- 4 = Control unit
- 5 = Battery
- 6 = Motor

Technical data	ECdrive	ECdrive FR
Transformer	Ring core with fuse and main switch	
Voltage	230 V	
Frequency	50 – 60 Hz	
Capacity rating	150 W	
Lock	Toothed belt locking, electromagnetic, two-stage	
Roller carriage		
Door leaf adjustment vertical	10 mm	
Door leaf adjustment horizontal	15 mm	
Anti-tilt protection	fitted as standard	
Self-cleaning	●	●
Control unit	DCU1-NT	DCU1-2M-NT
With fault memory	●	●
With memory for statistical data	●	●
Software update possible	●	●
Optional bus interface	●	●
Connection for fire alarm system	●	●
Power supply for peripherals	●	●
Programmable inputs	3 pc.	
Programmable outputs	2 pc.	
Battery	NiCd, 24 V, 700 mAh	
Motor	Gear motor	Double gear motor
Torque	400 Ncm	

● = YES

Fitting variations

Fittings	ECdrive
ISO glass fine-framed	●
MONO glass fine-framed	●
ESG clamping profile	●
All-glass system (GGS)	-
Integrated all-glass system (IGG)	-
Frame leaf (provided by customer)	●
Wooden leaf (provided by customer)	●

● = YES
- = NOT AVAILABLE

Calculation of the drive length (AL) in mm*

	ECdrive		ECdrive-FR**	
	Opening width (ÖW)	Drive length (AL)	Opening width (ÖW)	Drive length (AL)
2-leaf	900 - 3000	$2 \times \text{ÖW} + 100$	900 - 3000	$2 \times \text{ÖW} + 100$
1-leaf	700 - 3000	$2 \times \text{ÖW} + 60$	700 - 3000	$2 \times \text{ÖW} + 60$

* Minimum overall length of the complete system with ISO glass profile system

** For FR versions (FR-RWS, FR-LL).

Note:

Opening widths of escape route sliding doors < 1000 mm are only permitted in exceptional cases.
A continuous floor guide is recommended for external systems from an opening width of 2000 mm.
The minimum opening widths depend on the requirements of building law.

Calculation of leaf and glass dimension in mm

		ISO-glass with Alu-NSK	ISO-glass with rubber NSK	ESG
Leaf width	1-leaf	$\text{ÖW} + 40$	$\text{ÖW} + 35$	$\text{ÖW} + 35$
	2-leaf	$\text{ÖW} / 2 + 40$	$\text{ÖW} / 2 + 35$	$\text{ÖW} / 2 + 35$
Leaf height	with cover 120 mm	$\text{DH} + 25$		
	with cover 150 mm	$\text{DH} + 55$		
Glass width	1-leaf	ÖW	ÖW	$\text{ÖW} + 9$
	2-leaf	$\text{ÖW} / 2$	$\text{ÖW} / 2$	$\text{ÖW} / 2 + 9$
Glass weight		FH - 90	FH - 90	FH - 85
Glass thickness		22	22	10, 12

NSK = secondary closing edge

Note:

max. leaf ratio width to height 1:4

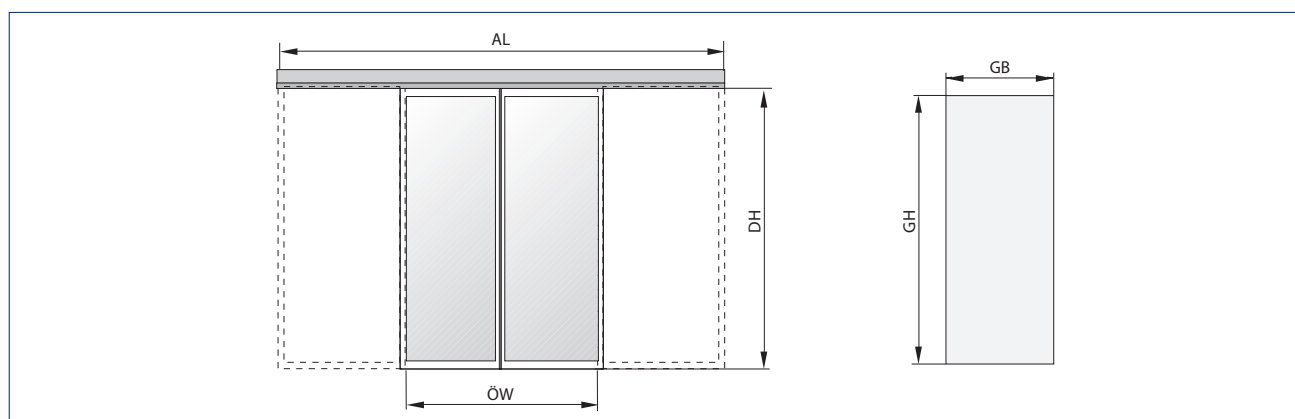

AL = Drive length
DH = Passage height
GB = Glass width
GH = Glass height
ÖW = Opening width

GEZE ECdrive

Support beam ECdrive ISO glass fitting

1-leaf

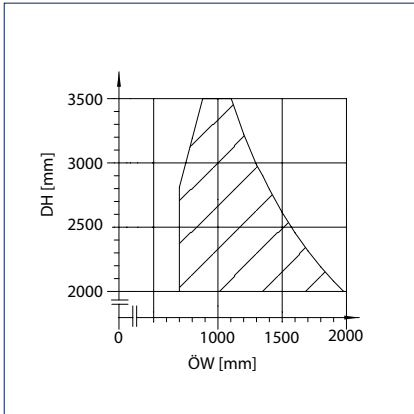

DH = Passage height
 ÖW = Opening width

2-leaf

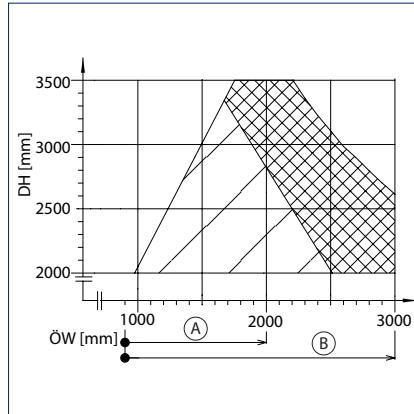

A = External application
 B = Internal application
 DH = Passage height
 ÖW = Opening width

Profiles

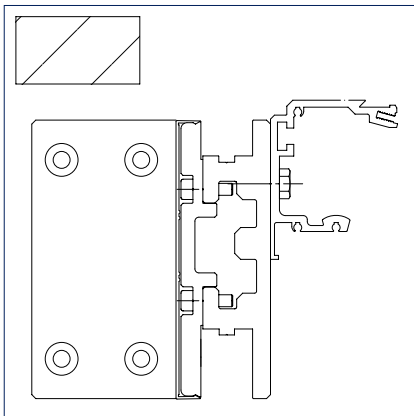

Standard

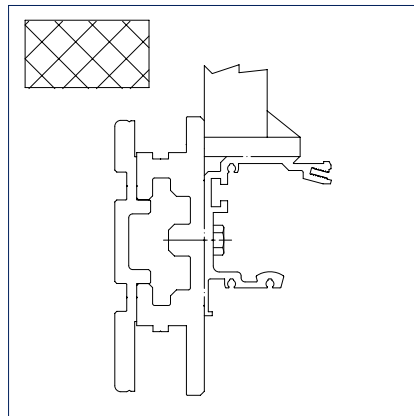

Carrier and track additionally suspended from the ceiling

With ISO/MONO glass fitting – without side part

Drawing no. 70504-ep01

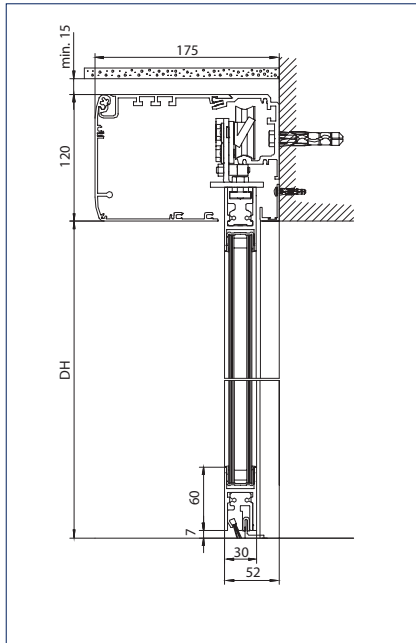

Floor guide: for floor mounting

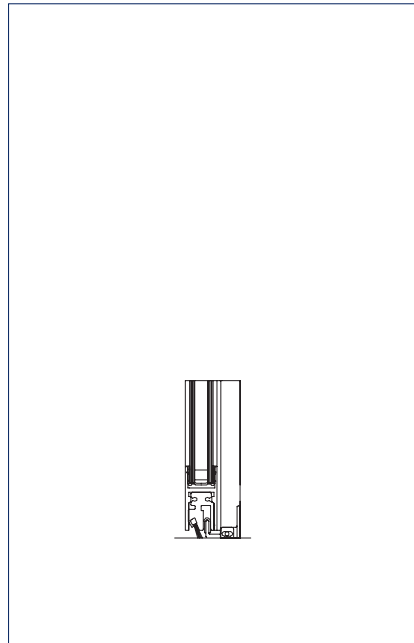

Floor guide: adjustable for wall assembly

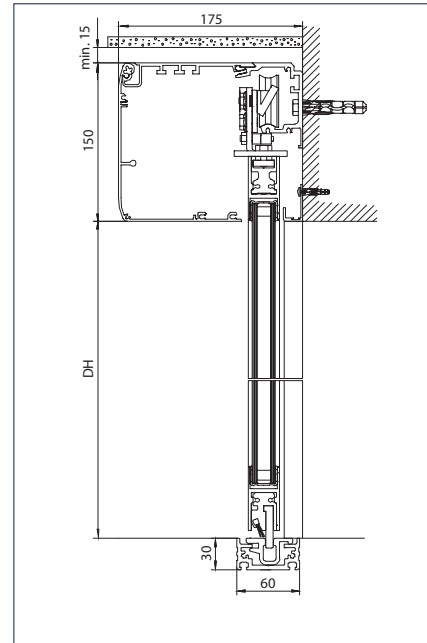

Floor guide: continuous

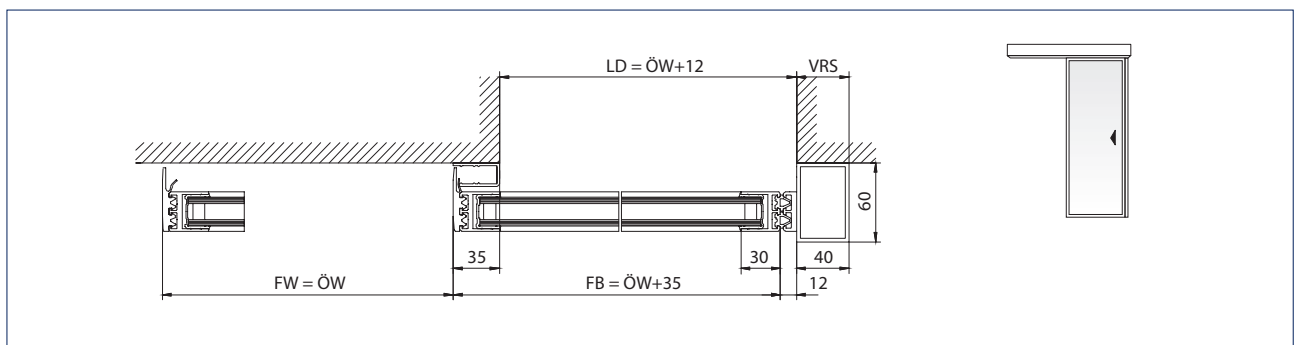

1-leaf door system

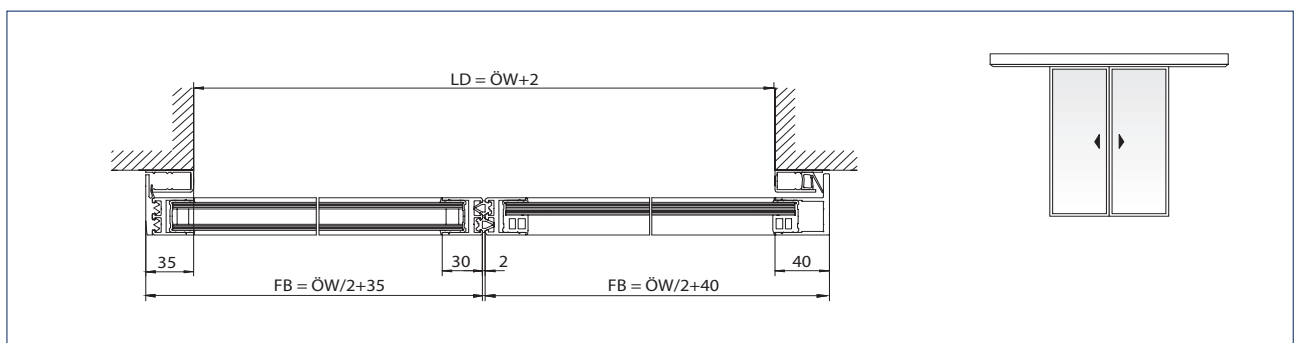

2-leaf door system

- LD = Clear passage
- FW = Travel path
- FB = Leaf width
- ÖW = Opening width
- VRS = Drive extension right
- DH = Passage height

With ISO/MONO glass fitting – with side part

Drawing no. 70504-ep12

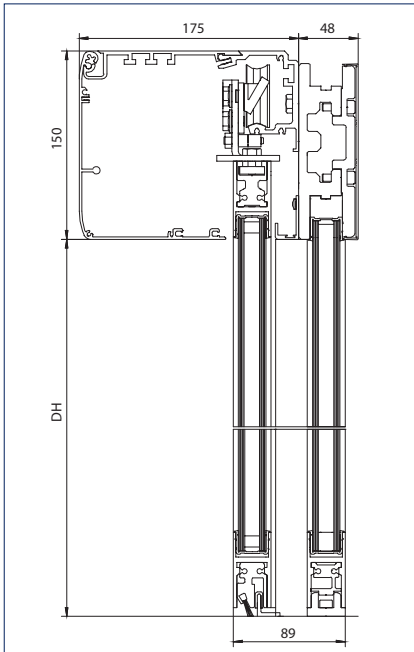

Low self-supporting beam

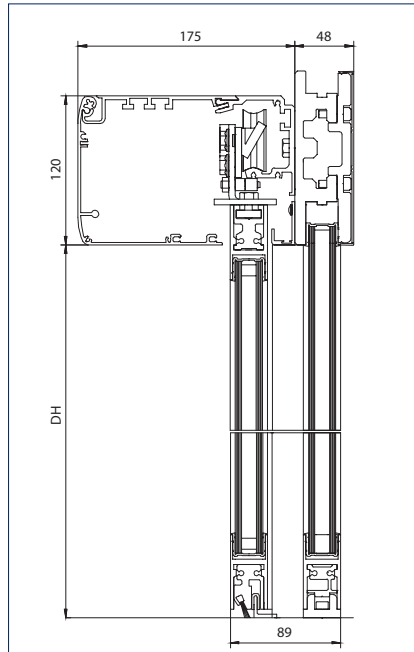

High self-supporting beam

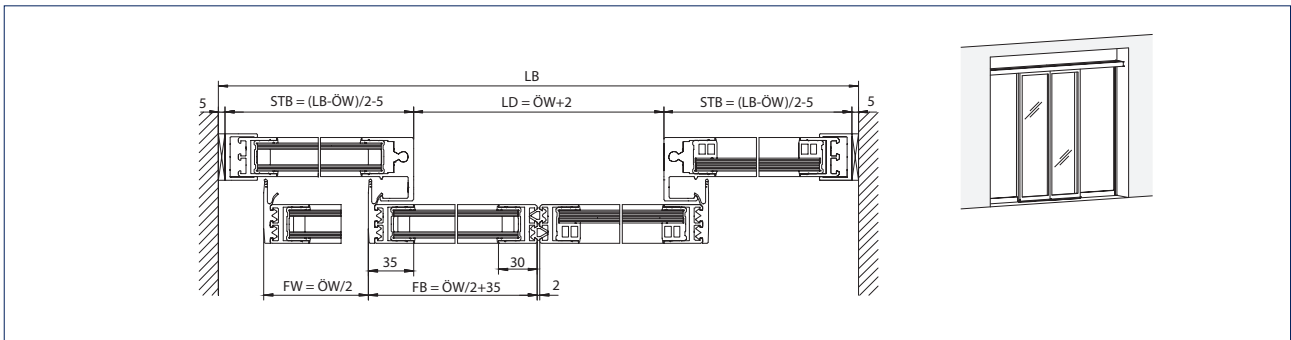

Installation: self-supporting installation

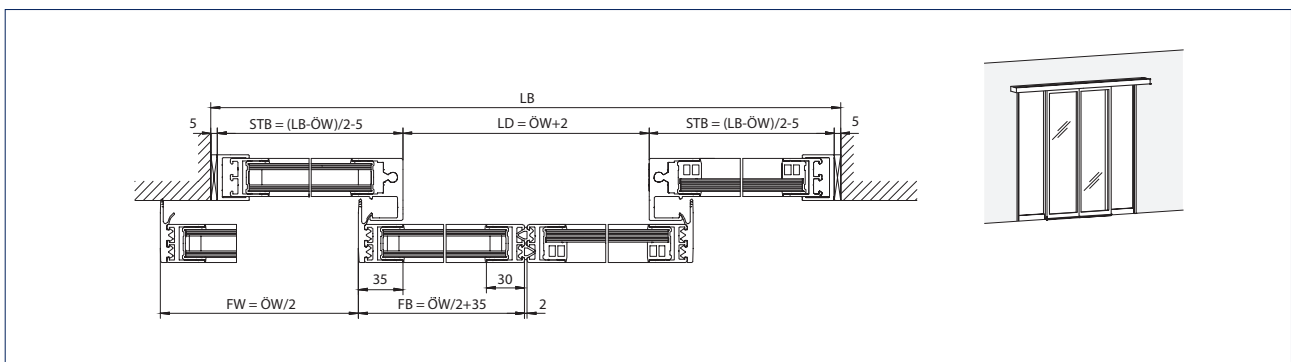

Installation: wall assembly with longer drive and carrier between the walls

- LB = Clear construction width
- STB = Width of side parts
- LD = Clear passage
- FW = Travel path
- FB = Leaf width
- ÖW = Opening width
- DH = Passage height

Note: See installation drawing for area of application

With ISO/MONO glass fitting – with protective leaf

Drawing no. 70504-ep11

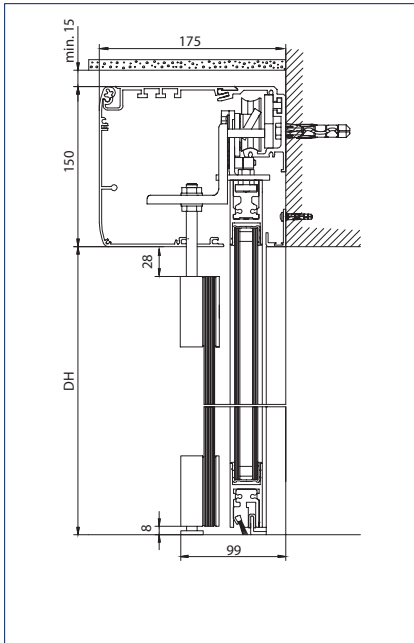

Protective leaf: drive installation

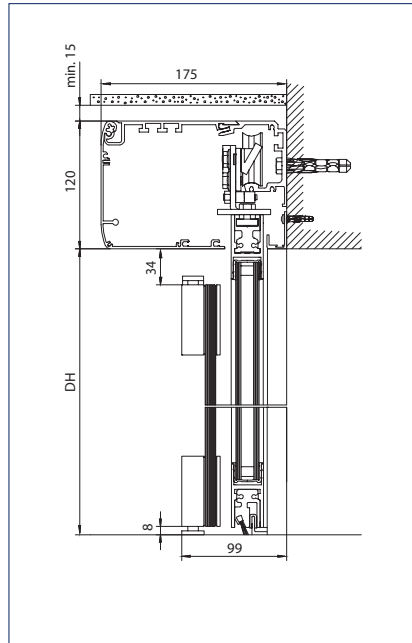

Protective leaf: wall assembly

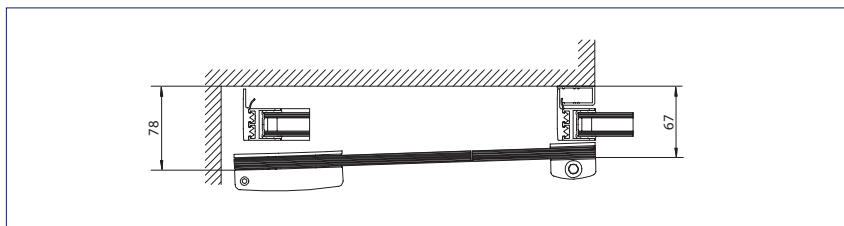

Protective leaf

With ISO/MONO glass fitting – with safety leaf

Drawing no. 70504-ep14

Note: See installation drawing for area of application

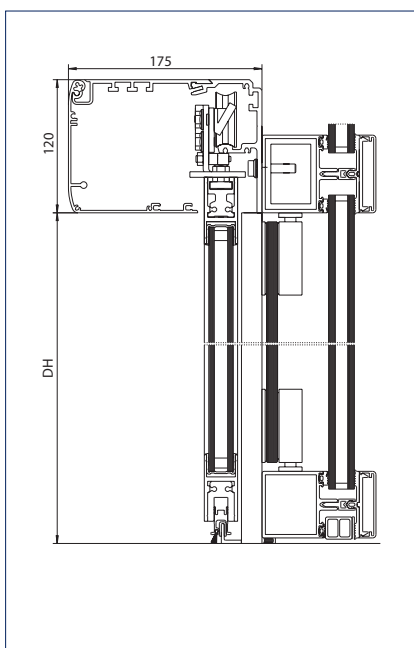

Installation: On post-rail construction with safety leaf

DH = Passage height

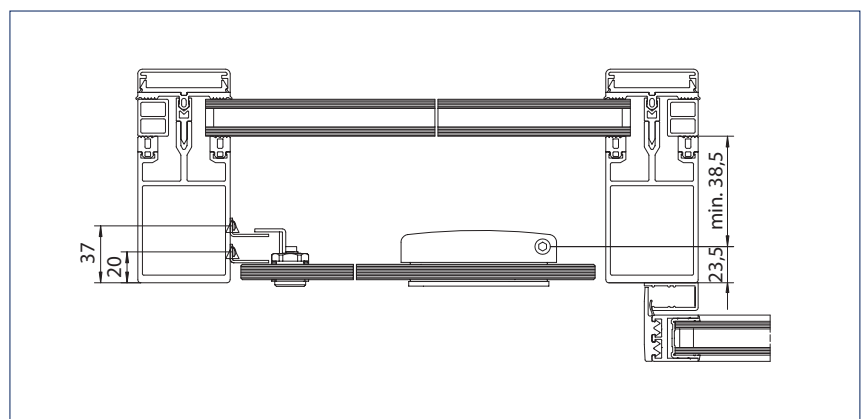

Installation: On post-rail construction with safety leaf

Toughened safety glass clamp fitting – without side part

Drawing no. 70506-ep03

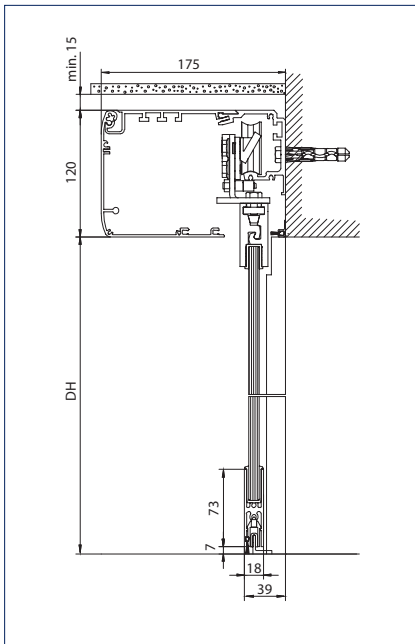

Floor guide: for floor mounting

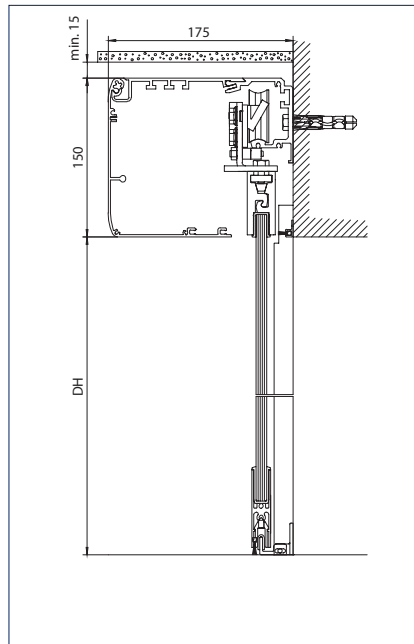

Floor guide: adjustable for wall assembly

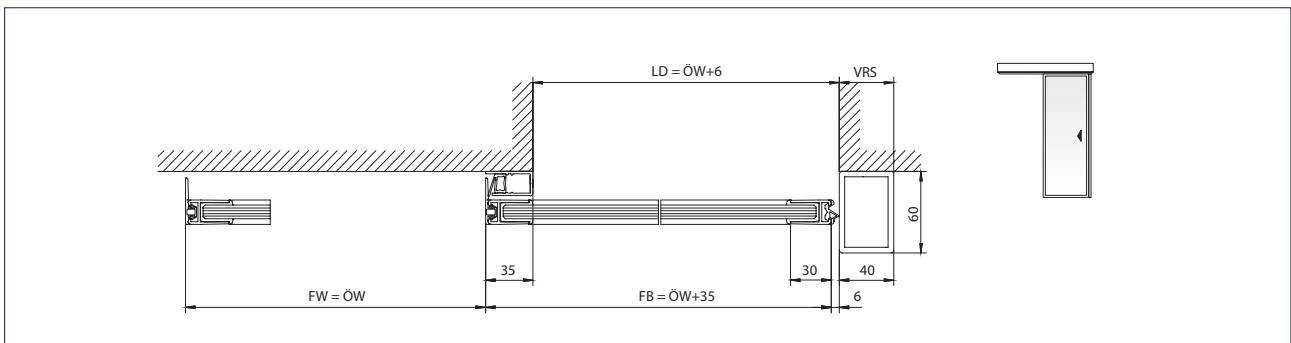

1-leaf door system

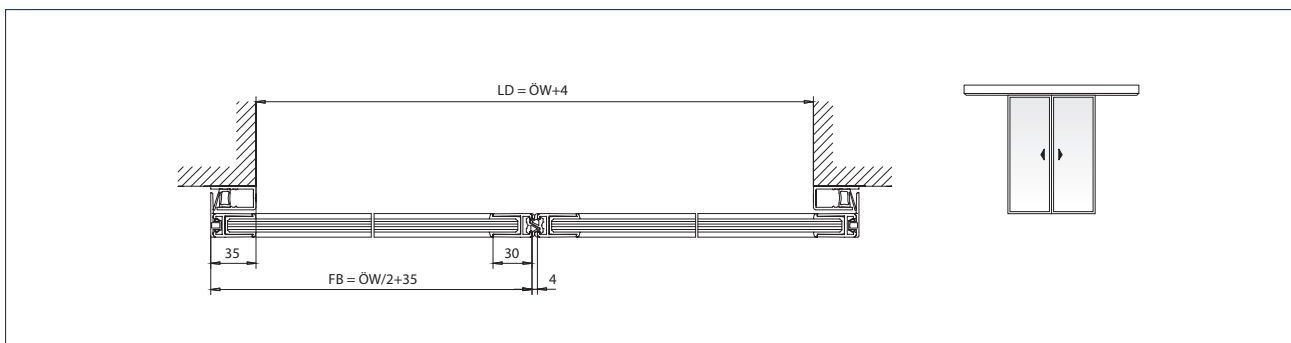

2-leaf door system

- LD = Clear passage
- FW = Travel path
- FB = Leaf width
- ÖW = Opening width
- VRS = Drive extension right
- DH = Passage height

Toughened safety glass clamp fitting – with side part

Drawing no. 70504-ep13

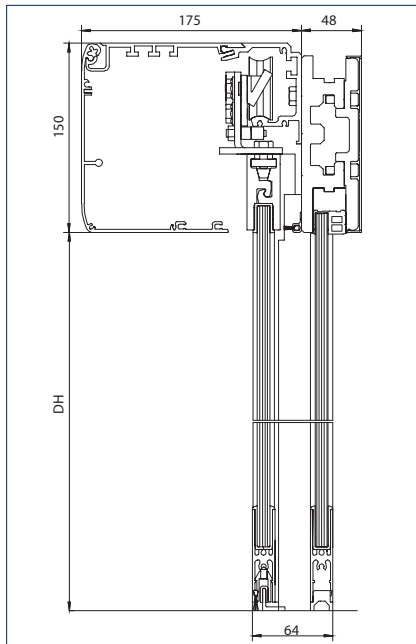

Version with 120 mm cover

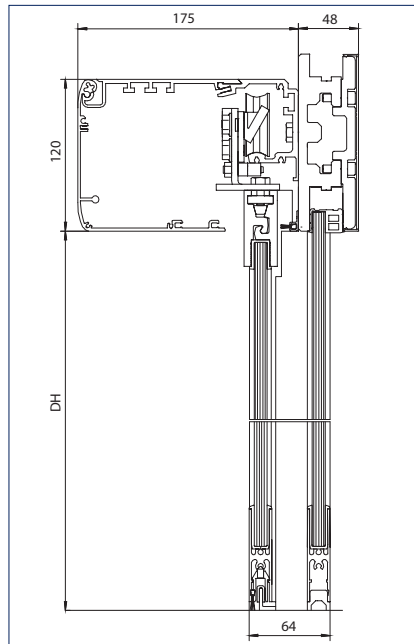

Version with 150 mm cover

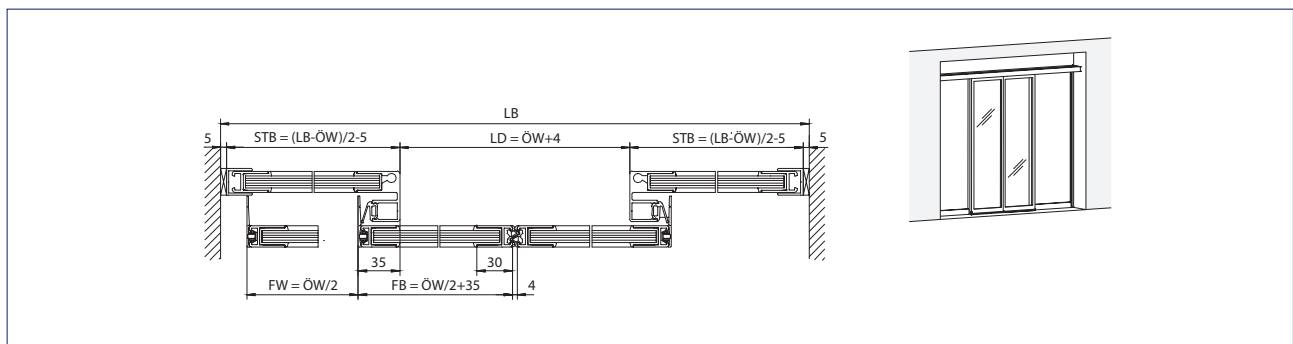

Installation: self-supporting installation

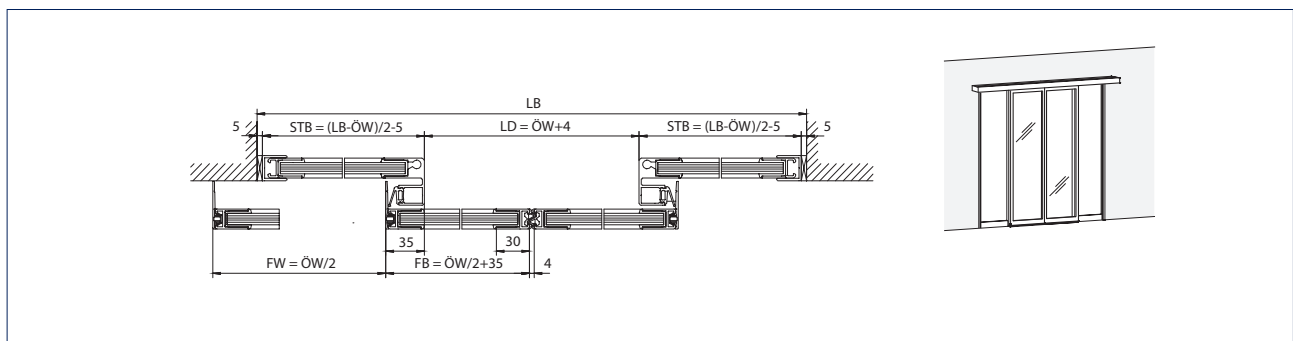

Installation: wall assembly with longer drive and carrier between the walls

- LB = Clear construction width
- STB = Width of side parts
- LD = Clear passage
- FW = Travel path
- FB = Leaf width
- ÖW = Opening width
- DH = Passage height

Note: See installation drawing for area of application

GEZE ECdrive

With on-site wooden leaf

Drawing no. 70504-ep09

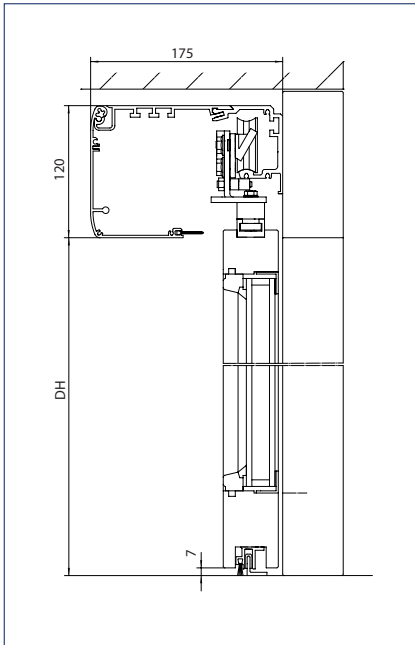

Version with 120 mm cover and continuous floor guide

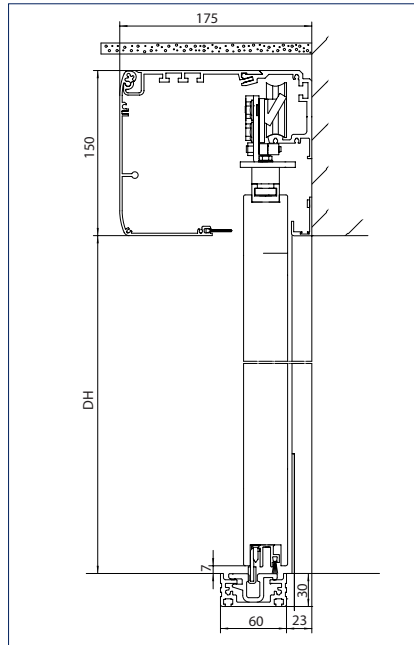

Version with 150 mm cover and floor guide for floor mounting

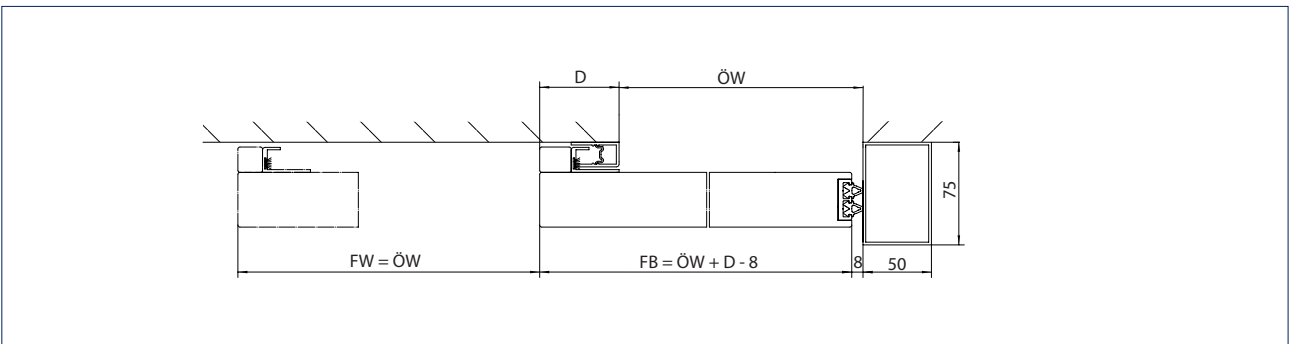

1-leaf door system

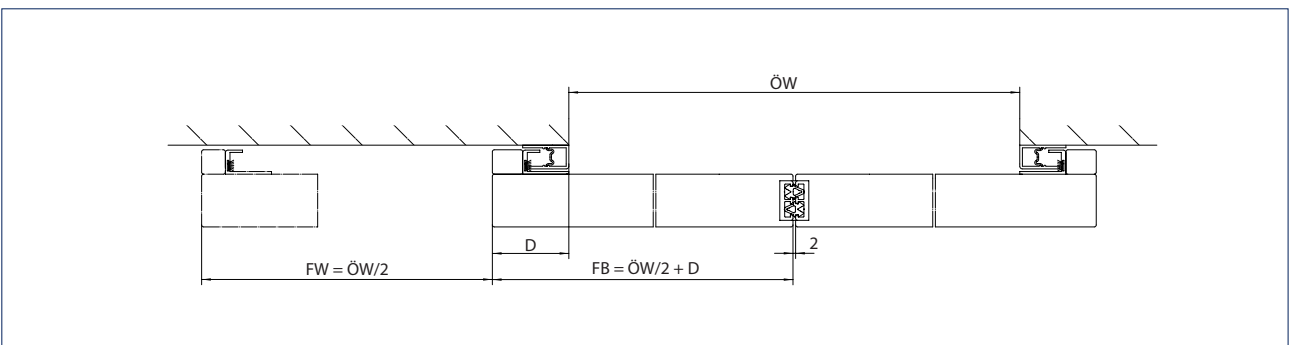

2-leaf door system

- D = Projection
- FB = Leaf width
- FW = Travel path
- ÖW = Opening width
- DH = Passage height



ECdrive, Akbati, Istanbul, Turkey (photo: Tarik Kaan Muşlu)

GEZE SLIMDRIVE SL NT

GEZE Slimdrive SL NT

Drive system for automatic linear sliding doors using the latest technology

Façades with slim post-rail structures seem even lighter and more inviting if they discreetly and easily blend in with the building architecture. The new automatic sliding door system GEZE Slimdrive SL NT is ideal – particularly in glass façades where large door leaves have to be moved and all components have to appear slim and delicate.

With its low drive height of only 7 cm, the Slimdrive SL NT can be integrated almost invisibly in the façade and moves door leaf weights of up to 125 kg. The new track makes mounting directly on the wall, façade or on support beams easier. Standard self-cleaning roller carriages guarantee smooth running and increase the roller carriage service life. Additional supporting rollers increase steadiness.



Technical data

Product features	SL NT	SL NT-FR
For 1-leaf door systems	•	•
For 2-leaf door systems	•	•
Height	70 mm	
Depth	190 mm	
Leaf weight (max.) 1-leaf	125 kg	
Leaf weight (max.) 2-leaf	125 kg	
Opening width 1-leaf	700 – 3000 mm	
Opening width 2-leaf	900 – 3000 mm	
Temperature range	-15 – 50 °C	
IP rating	IP20	
Disconnection from mains	Main switch in the drive	
Opening speed (max.)	0.8 m/s	
Closing speed (max.)	0.8 m/s	
Hold-open time	0 – 60 S	
Adjustable opening and closing force (max.)	150 N	
Automatic adaptation to traffic flow	•	•
Automatic reversal when an obstacle is detected	•	•
Pharmacy opening	•	•
Interlocking door system function	•	-
Vestibule function	•	-
Automatic opening in the event of a power failure	adjustable	fitted as standard
Automatic closing in the event of a power failure	adjustable	not available
Function in the event of a power failure	adjustable for 30 min. / 30 cycles	open
Automatic opening in the event of a fault	not available	fitted as standard
Approvals	DIN 18650, BGR232, DIN EN ISO 13849: Performance Level D	DIN 18650, BGR232 DIN EN ISO 13849: Performance Level D, AutSchR

• = YES
- = NOT AVAILABLE

Drive components

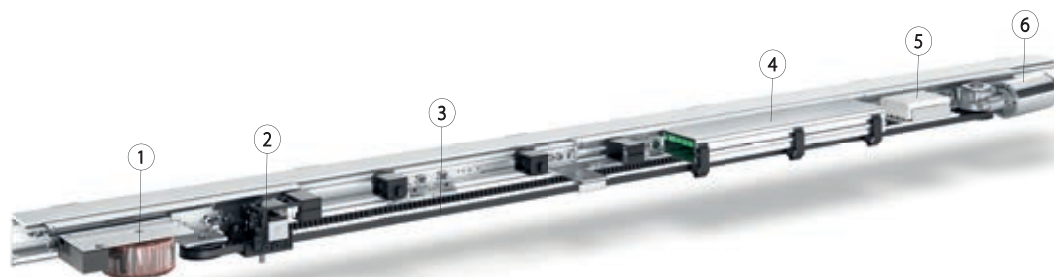

- 1 = Transformer
- 2 = Lock
- 3 = Roller carriage
- 4 = Control unit
- 5 = Battery
- 6 = Motor

Technical data	SL NT	SL NT-FR
Transformer	Ring core with fuse and main switch	
Voltage	230 V	
Frequency	50 – 60 Hz	
Capacity rating	150 W	
Lock	Toothed belt locking, electromagnetic, two-stage	
Roller carriage		
Door leaf adjustment vertical	10 mm	
Door leaf adjustment horizontal	6 mm	
Anti-tilt protection	fitted as standard	
Self-cleaning	•	•
Control unit	DCU1-NT	DCU1-2M-NT
With fault memory	•	•
With memory for statistical data	•	•
Software update possible	•	•
Optional bus interface	•	•
Connection for fire alarm system	•	•
Power supply for peripherals	•	•
Programmable inputs	3 pc.	
Programmable outputs	2 pc.	
Battery	NiCd, 24 V, 700 mAh	
Motor	Gear motor	Double gear motor
Torque	400 Ncm	

• = YES

Fitting versions

Fittings	Slimdrive SL NT
ISO glass fine-framed	•
MONO glass fine-framed	•
ESG clamping profile	-
All-glass system (GGS)	•
Integrated all-glass system (IGG)	•
Frame leaf (provided by customer)	•
Wooden leaf (provided by customer)	•

• = YES
- = NOT AVAILABLE

GEZE SLIMDRIVE SL NT

Calculation of the drive length (AL) in mm*

	Slimdrive SL NT		Slimdrive SL NT-FR**	
	Opening width (ÖW)	Drive length (AL)	Opening width (ÖW)	Drive length (AL)
2-leaf	900 - 1000	ÖW + 1100	900 - 1070	ÖW + 1170
	1000 - 3000	2 x ÖW + 100	1070 - 3000	2 x ÖW + 100
1-leaf, closing on the right	700 - 3000	2 x ÖW + 60	700 - 800	ÖW + 860
			800 - 3000	2 x ÖW + 60
1-leaf, closing on the left	700 - 3000	2 x ÖW + 60	700 - 800	ÖW + 860
			800 - 3000	2 x ÖW + 60

When using Lock A, the drive length increases by 100 mm.

When using Lock M on 1-leaf doors, the drive length increases by 100 mm. When using Lock M on 2-leaf doors, the drive length increases by 100 mm only if an optional lock notification is installed.

* Minimum overall length of the complete system with ISO glass profil system

** Request drawing for the FR-RWS, FR-LL variations!

Note:

Opening widths of escape route sliding doors < 1000 mm are only permitted in exceptional cases.

A continuous floor guide is recommended for external systems from an opening width of 2000 mm.

The minimum opening widths depend on the requirements of building law.

Calculation of leaf and glass dimensions in mm (ISO glass profile system)

		ISO-glass
Leaf width	1-leaf	ÖW + 35
	2-leaf	ÖW / 2 + 35
Leaf height	1-leaf / 2-leaf	FH = DH - 2
Glass width	1-leaf	ÖW
	2-leaf	ÖW / 2
Glass height	1-leaf / 2-leaf	FH - 90
Glass thickness		22

Note:

max. leaf ratio width to height 1:4

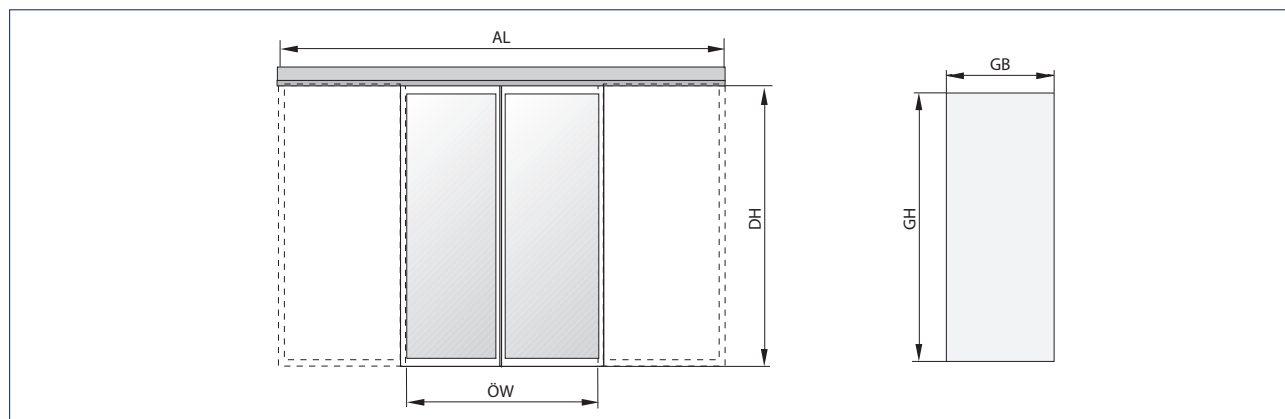

- AL = Drive length
- DH = Passage height
- GB = Glass width
- GH = Glass height
- ÖW = Opening width

With support beam, ISO glass fitting

1-leaf

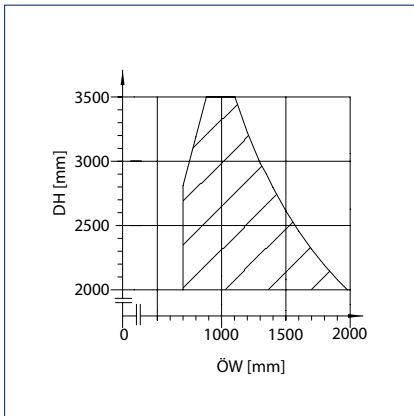

DH = Passage height
 ÖW = Opening width

2-leaf

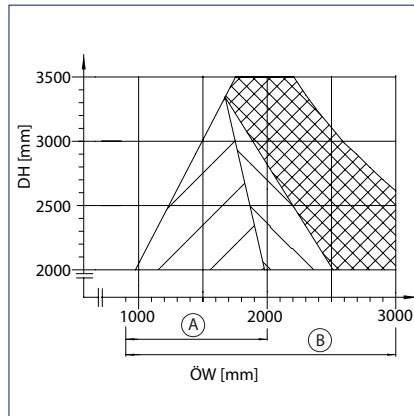

A = External application
 B = Internal application
 DH = Passage height
 ÖW = Opening width

Profiles

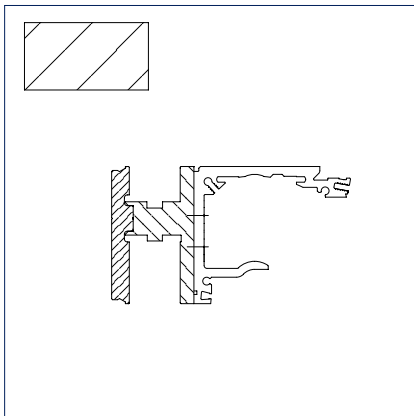

Profile standard carrier SL NT

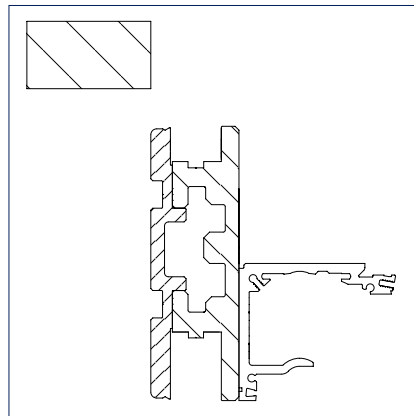

Additional carrier EC/SL

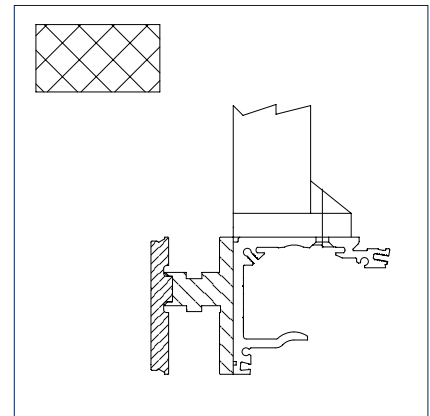

Profile for carrier and track additionally suspended from the ceiling

GEZE SLIMDRIVE SL NT

With ISO/MONO glass fitting – without side part

Drawing no. 70511-ep01

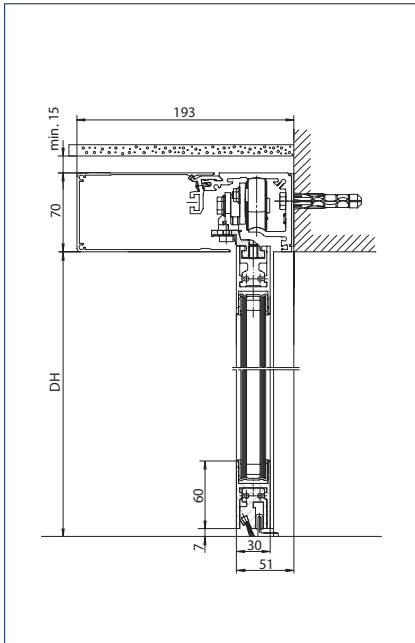

Floor guide: for floor mounting



Floor guide: adjustable for wall assembly



Floor guide: continuous

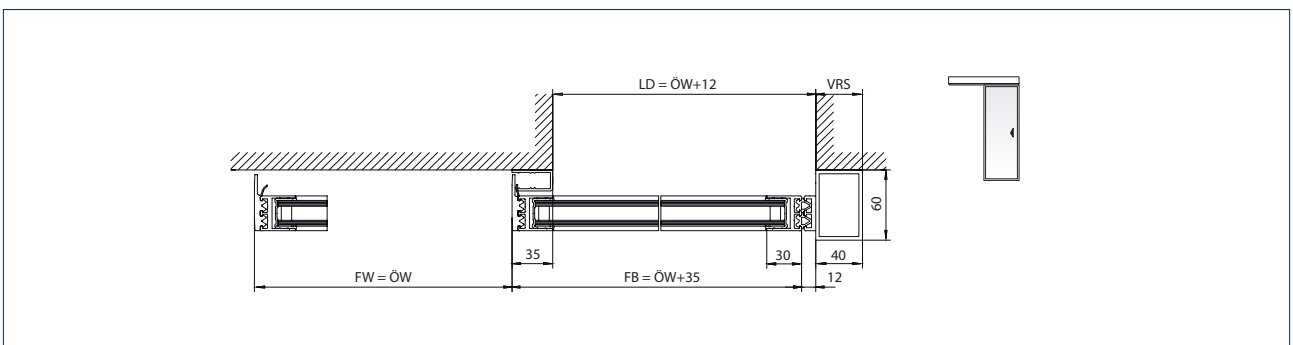

1-leaf door system

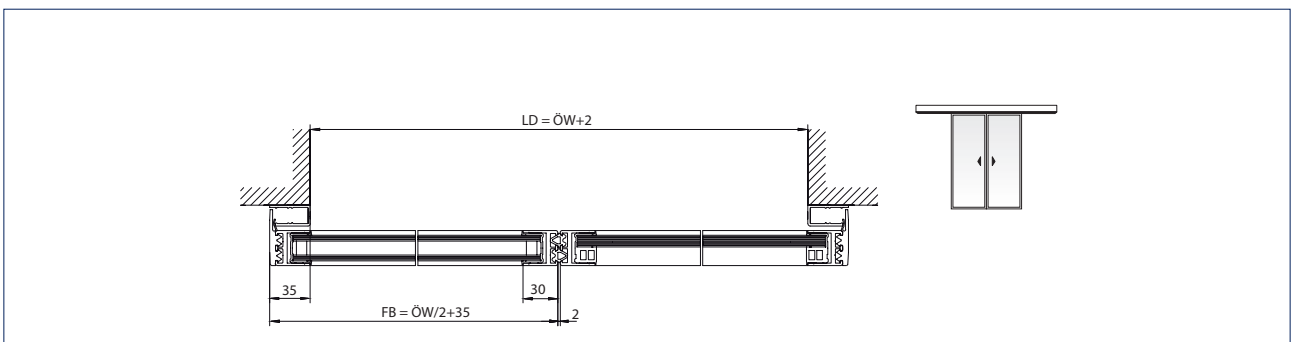

2-leaf door system

- LD = Clear passage
- FW = Travel path
- FB = Leaf width
- ÖW = Opening width
- VRS = Drive extension right
- DH = Passage height

With ISO/MONO glass fitting – with side part

Drawing no. 70511-ep02 + 70511-ep04

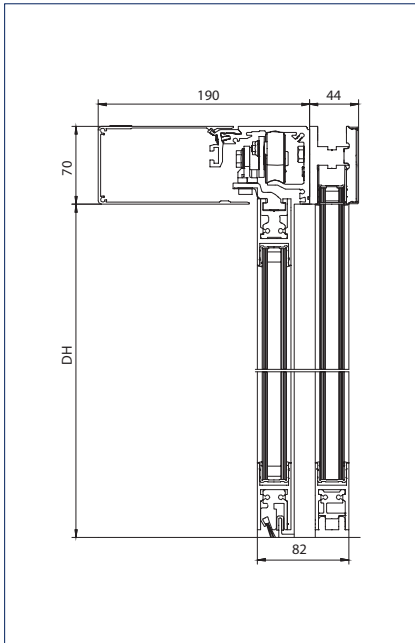

Low self-supporting beam

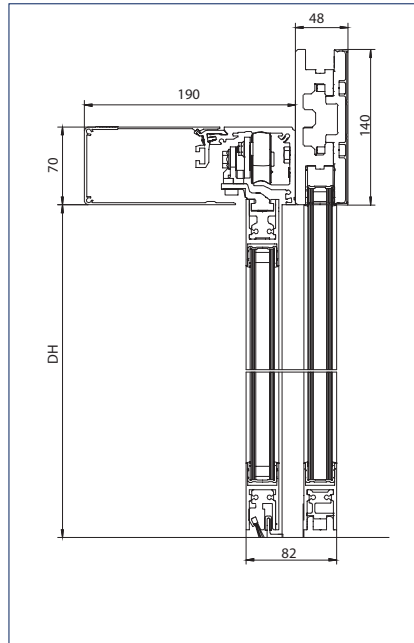

High self-supporting beam

Note: See installation drawing for area of application

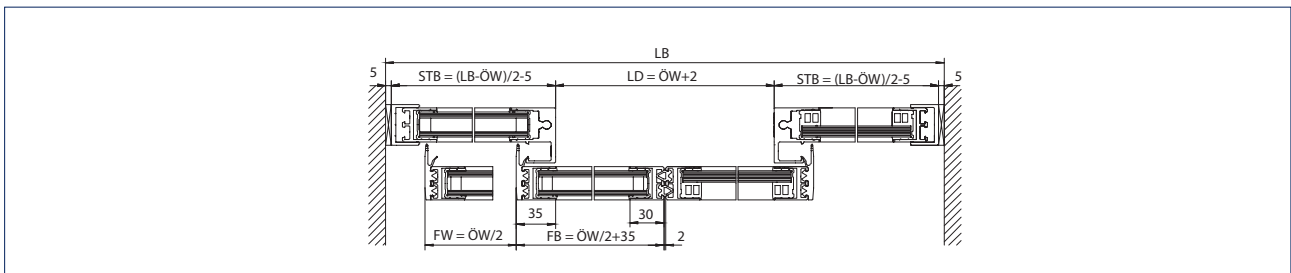

Installation: self-supporting installation

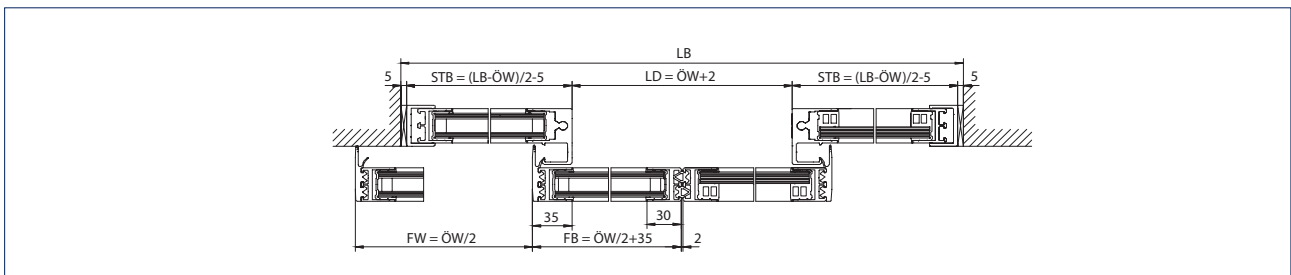

Installation: wall assembly with longer drive and carrier between the walls

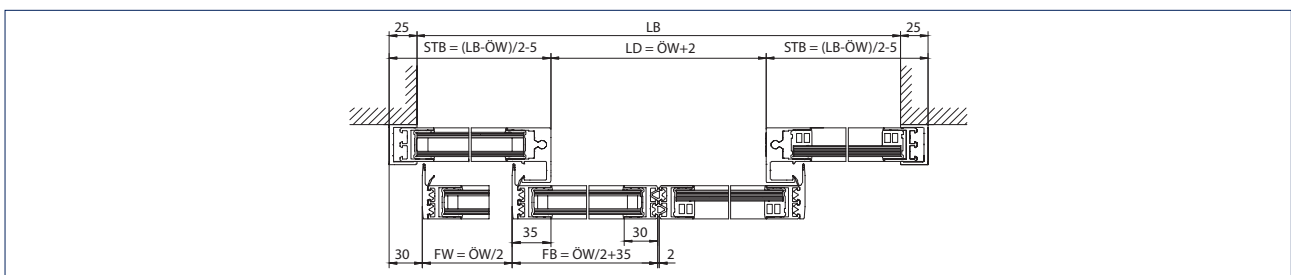

Installation: wall assembly

- LB = Clear construction width
- STB = Width of side parts
- LD = Clear passage
- FW = Travel path
- FB = Leaf width
- ÖW = Opening width
- DH = Passage height

GEZE SLIMDRIVE SL NT

With protective leaf

Drawing no. 70511-ep07

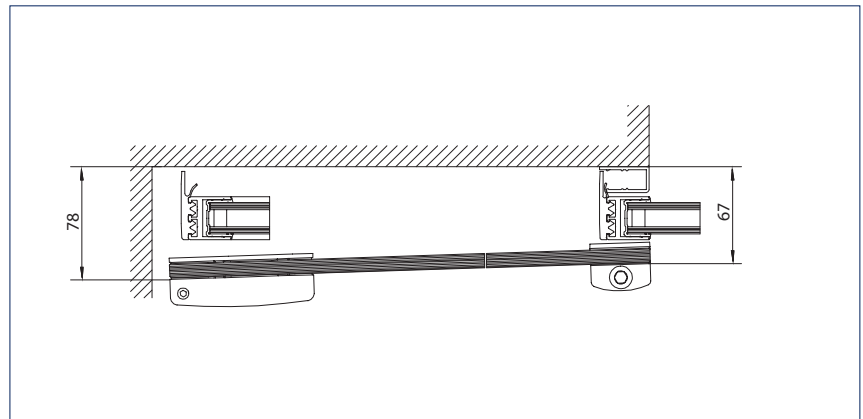
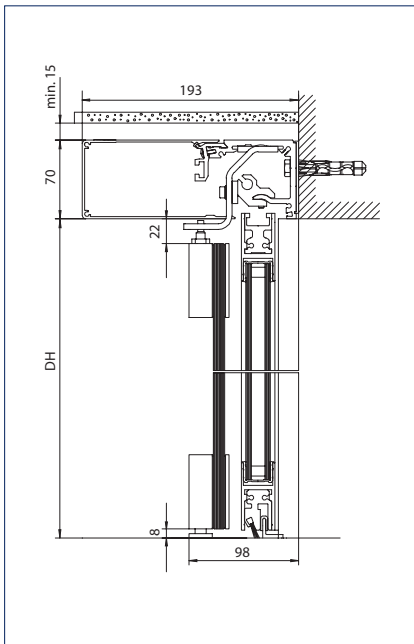

Protective leaf

Protective leaf: drive installation
DH = Passage height

With safety leaf

Drawing no. 70511-ep03

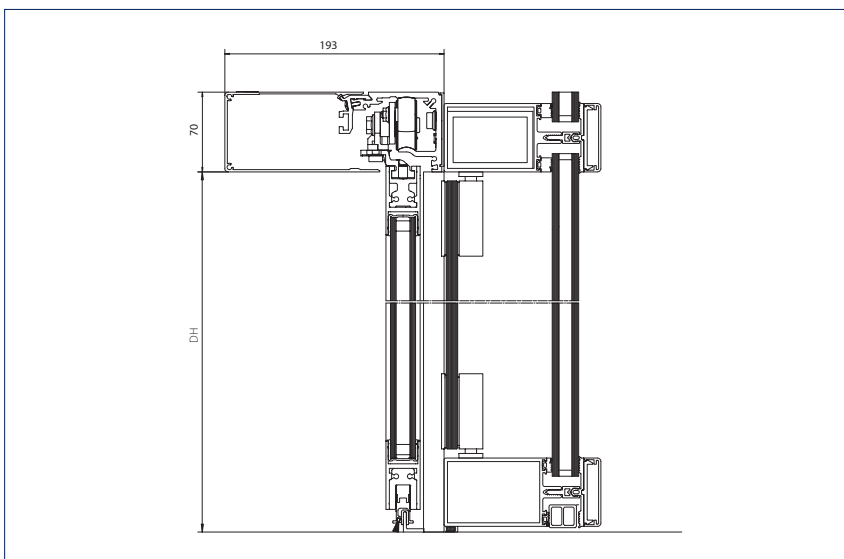

Installation: on post-rail construction with safety leaf

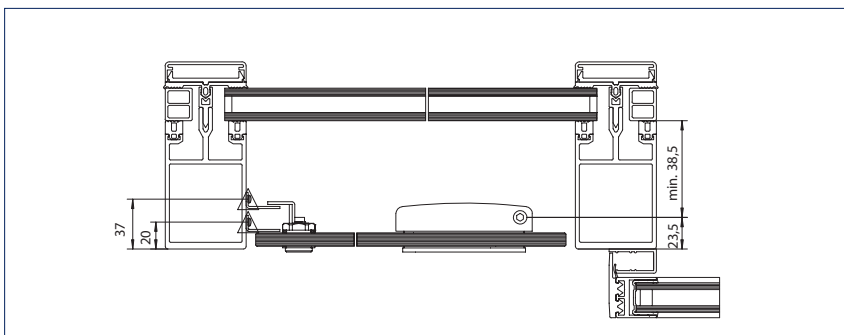

Installation: on post-rail construction with safety leaf
DH = Passage height

Note: See installation drawing for area of application

With all-glass system (GGS) – with and without side part

Drawing no. 70511-ep06

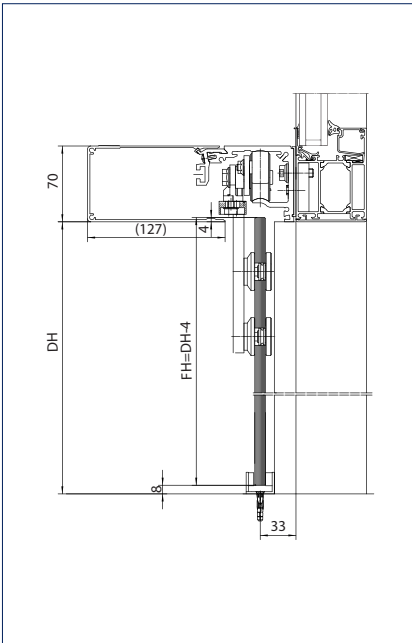

Door leaf

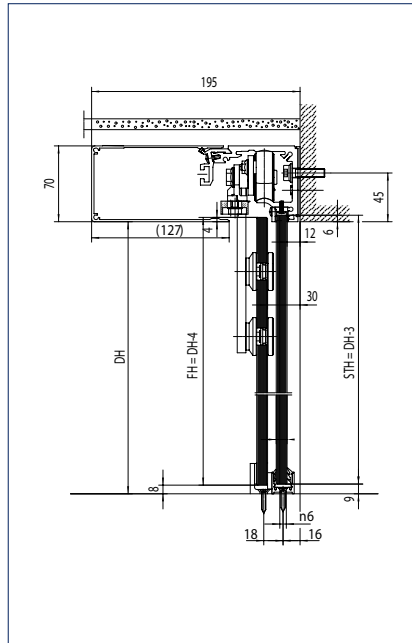

Door leaves and side parts

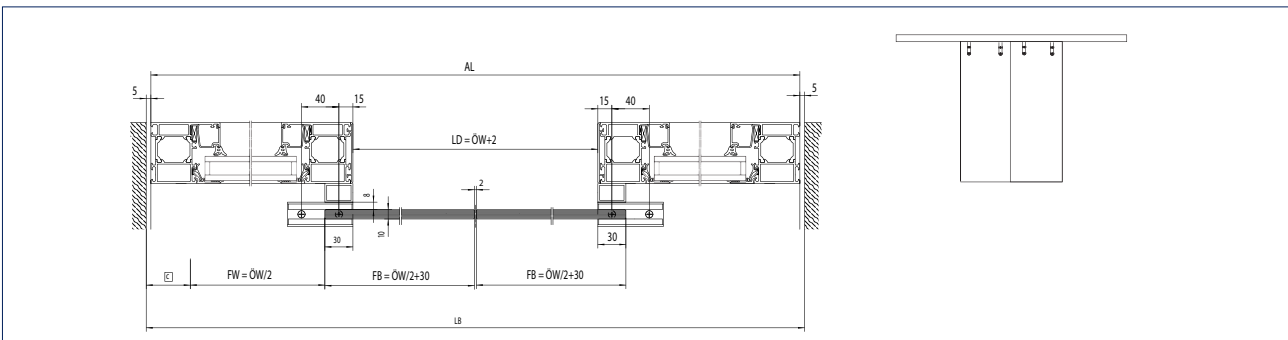

2-leaf door system with door leaf

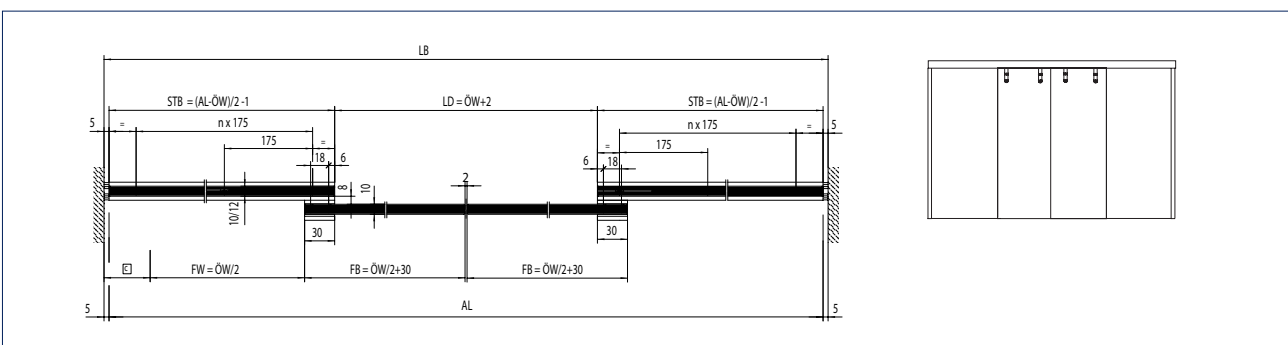

2-leaf door system with door leaf and side parts

- | | |
|---------------------------|-------------------------------|
| AL = Drive length | STH= Height of side parts |
| FW = Travel path | LB = Clear construction width |
| FB = Leaf width | LD = Clear passage |
| FH = Leaf height | ÖW = Opening width |
| STB = Width of side parts | DH = Passage height |

GEZE SLIMDRIVE SL NT

With integrated all-glass system (IGG) – with and without side parts

Drawing no. 70511-ep05

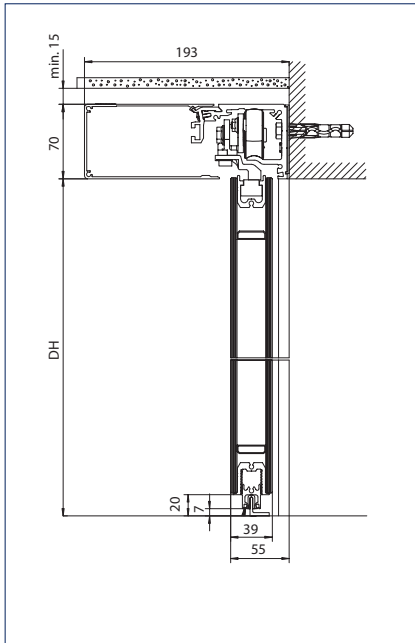

Floor guide: for floor mounting

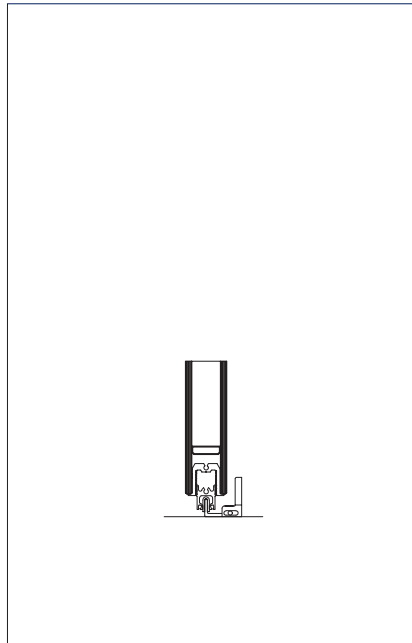

Floor guide: adjustable for wall assembly

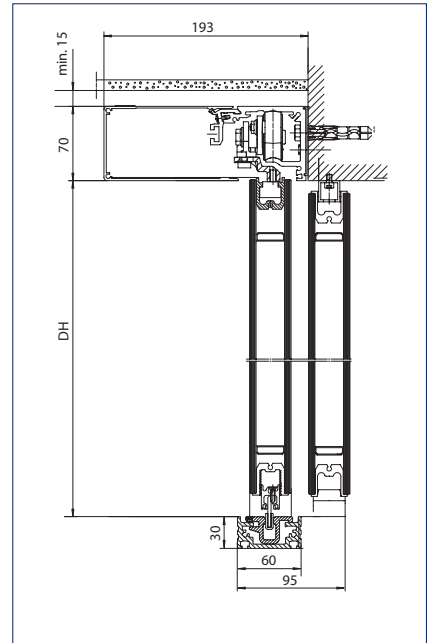

Floor guide: continuous

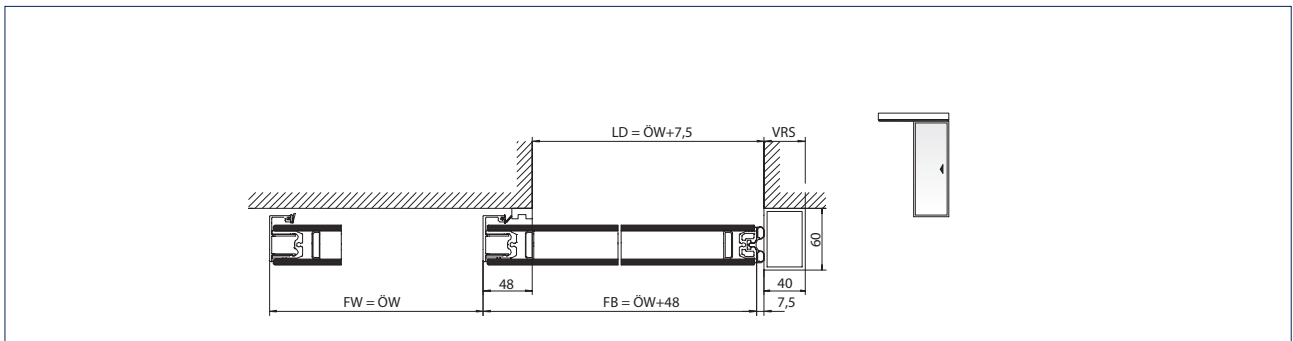

1-leaf door system

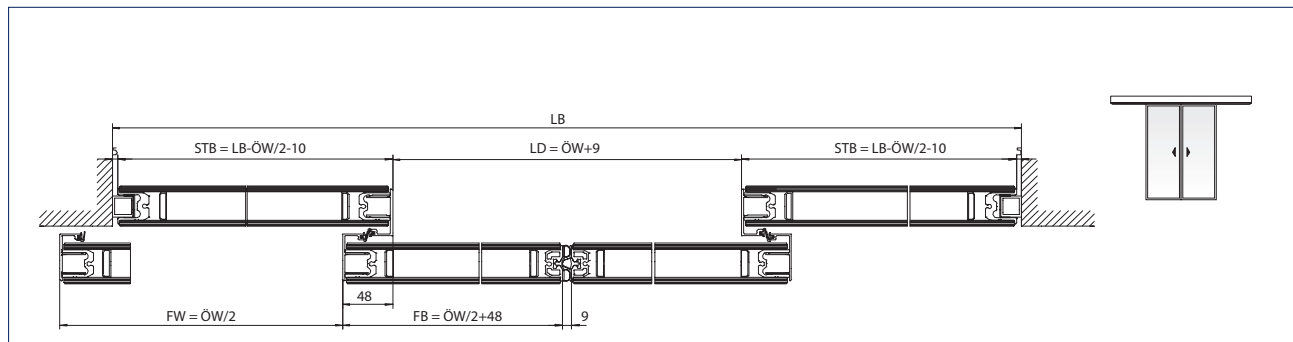

2-leaf door system

- | | |
|-------------------------------|-----------------------------|
| LD = Clear passage | DH = Passage height |
| FW = Travel path | FB = Leaf width |
| LB = Clear construction width | ÖW = Opening width |
| STB = Width of side parts | VRS = Drive extension right |

With on-site wooden leaf

Drawing no. 70511-ep08

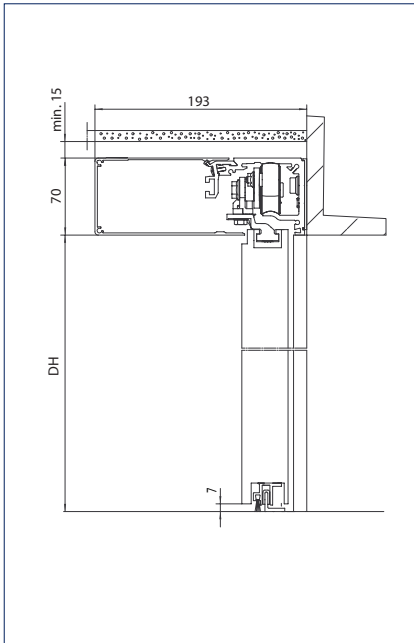

Installation variant for slimmer wooden leaves and floor guide for floor mounting

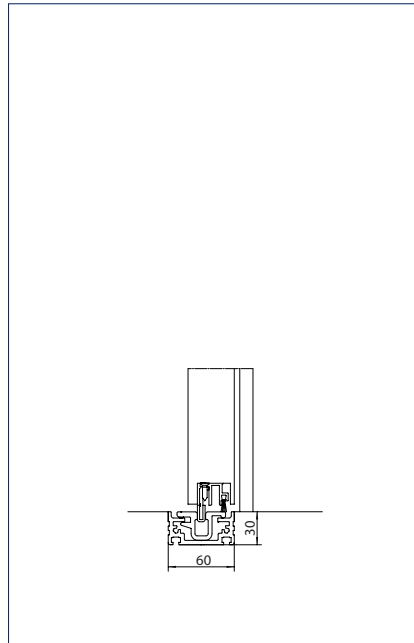

Alternative variant with continuous floor guide

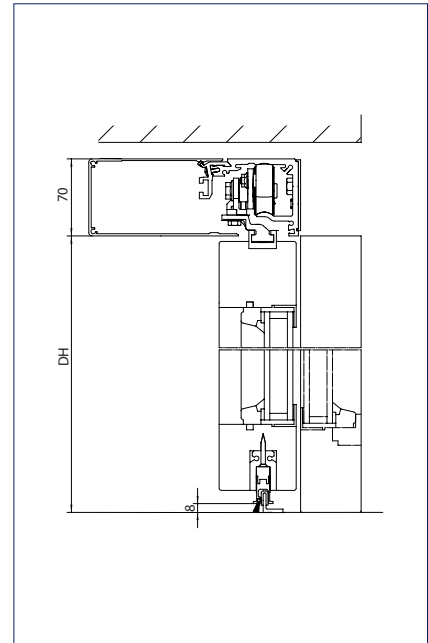

Installation variant for thicker wooden leaves and floor guide for floor mounting

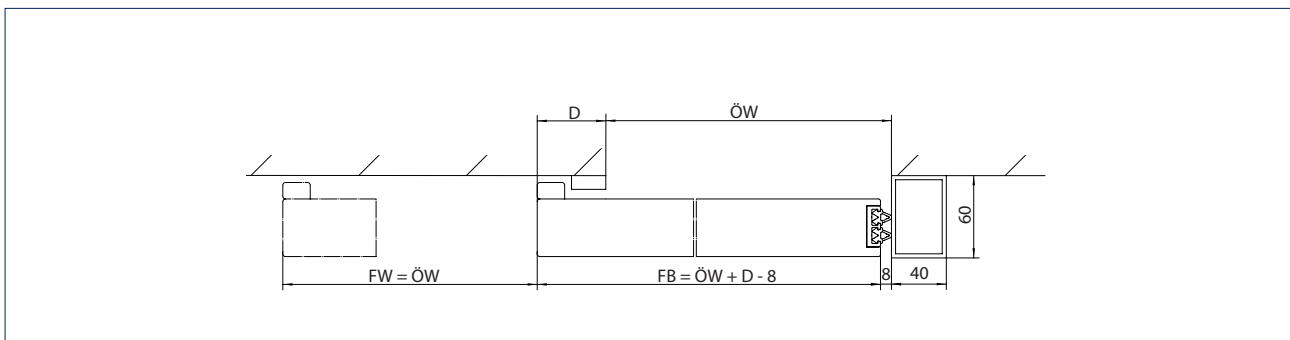

1-leaf door system

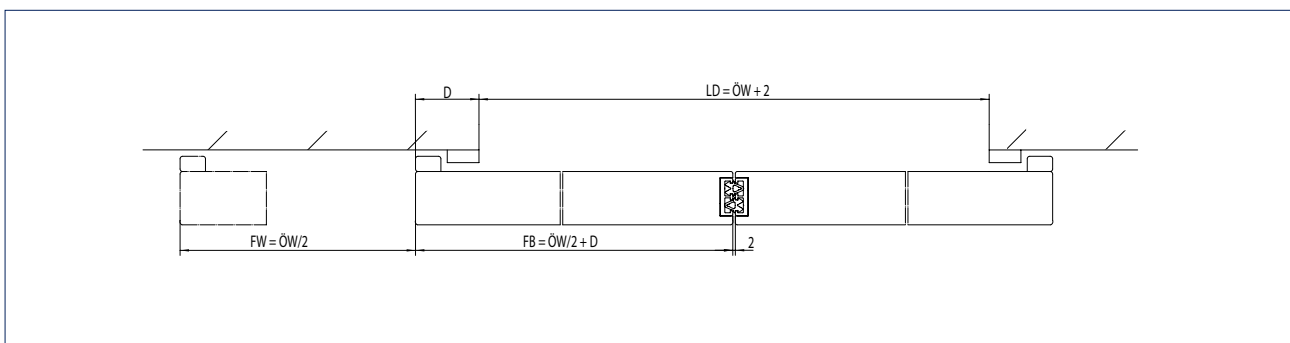

2-leaf door system

- D = Projection
- FB = Leaf width
- FW = Travel path
- ÖW = Opening width
- LD = Clear passage clearance
- DH = Passage height

GEZE POWERDRIVE PL

GEZE Powerdrive PL

Drive system for automatic linear sliding doors with large, heavy leaves

The trademarks of the Powerdrive series are convenience and safety even for heavy doors. Large entrances and opening widths combined with high leaves make special demands on door drive technology. And this is exactly where the strengths of the Powerdrive come into their own. Economic and powerful, this drive moves heavy door leaves up to 200 kg (in the escape route version up to 160 kg). Optimum running characteristics and low wear thanks to compatible profiling of the rollers and track allows use in areas with a high traffic flow.



Technical data

Product features	PL	PL-FR
For 1-leaf door systems	•	•
For 2-leaf door systems	•	•
Height	150 / 200 mm	
Depth	185 mm	
Leaf weight (max.) 1-leaf	200 kg	160 kg
Leaf weight (max.) 2-leaf	200 kg	160 kg
Opening width 1-leaf	700 – 3000 mm	
Opening width 2-leaf	800 – 3000 mm	
Temperature range	-15 – 50 °C	
IP rating	IP20	
Disconnection from mains	Main switch in the drive	
Opening speed (max.)	0.8 m/s	
Closing speed (max.)	0.8 m/s	
Hold-open time	0 – 60 S	
Adjustable opening and closing force (max.)	150 N	
Automatic adaptation to traffic flow	•	•
Automatic reversal when an obstacle is detected	•	•
Pharmacy opening	•	•
Interlocking door system function	•	-
Vestibule function	•	-
Automatic opening in the event of a power failure	adjustable	fitted as standard
Automatic closing in the event of a power failure	adjustable	not available
Function in the event of a power failure	adjustable for 30 min. / 30 cycles	open
Automatic opening in the event of a fault	not available	fitted as standard
Approvals	DIN 18650 BGR232 DIN EN ISO 13849: Performance Level D	DIN 18650 BGR232 DIN EN ISO 13849: Performance Level D AutSchR

• = YES
- = NOT AVAILABLE

Drive components

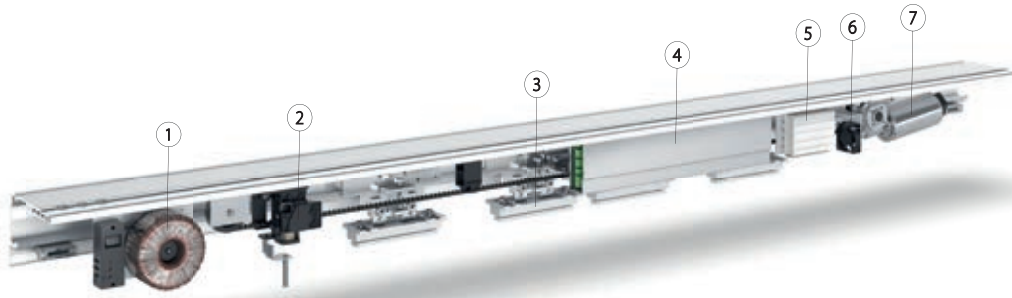

- | | |
|---------------------|-------------|
| 1 = Transformer | 5 = Battery |
| 2 = Lock | 6 = Fan |
| 3 = Roller carriage | 7 = Motor |
| 4 = Control unit | |

Technical data	PL	PL-FR
Transformer	Ring core with fuse and main switch	
Voltage	230 V	
Frequency	50 – 60 Hz	
Capacity rating	200 W	
Lock	Toothed belt locking, electromagnetic, two-stage	
Roller carriage		
Door leaf adjustment vertical	12 mm	
Door leaf adjustment horizontal	40 mm	
Anti-tilt protection	fitted as standard	
Self-cleaning	•	•
Control unit	DCU1-NT	DCU1-2M-NT
With fault memory	•	•
With memory for statistical data	•	•
Software update possible	•	•
Optional bus interface	•	•
Connection for fire alarm system	•	•
Power supply for peripherals	•	•
Programmable inputs	3 pc.	
Programmable outputs	2 pc.	
Battery	NiCd, 24 V, 700 mAh	
Motor	Gear motor	Double gear motor
Torque	400 Ncm	

• = YES

Fitting versions

Fittings	Powerdrive PL
ISO glass fine-framed	•
MONO glass fine-framed	•
ESG clamping profile	•
All-glass system (GGS)	-
Integrated all-glass system (IGG)	-
Frame leaf (provided by customer)	•
Wooden leaf (provided by customer)	•

• = YES
- = NOT AVAILABLE

GEZE POWERDRIVE PL

Calculation of the drive length AL in mm*

Powerdrive	PL		PL-FR**	
	Opening width (ÖW)	Drive length (AL)	Opening width (ÖW)	Drive length (AL)
2-leaf	800 - 3000	$2 \times \text{ÖW} + 100$	800 - 3000	$2 \times \text{ÖW} + 100$
1-leaf	700 - 3000	$2 \times \text{ÖW} + 65$	700 - 3000	$2 \times \text{ÖW} + 65$

* Minimum overall length of the complete system with ISO glass profile system

** Request drawing for FR variations (FR-RWS, FR-LL)!

Note:

Opening widths of escape route sliding doors < 1000 mm are only permitted in exceptional cases.
 A continuous floor guide is recommended for external systems from an opening width of 2000 mm.
 The minimum opening widths depend on the requirements of building law.

Calculation of leaf and glass dimension in mm

		ISO glass with NSK	ISO glass with NSK	ESG
		made of aluminium	made of rubber	
Leaf width	1-leaf	$\text{ÖW} + 40$	$\text{ÖW} + 35$	$\text{ÖW} + 35$
	2-leaf	$\text{ÖW} / 2 + 40$	$\text{ÖW} / 2 + 35$	$\text{ÖW} / 2 + 35$
Leaf height	with cover 150 mm	DH		
	with cover 200 mm	DH + 50		
Glass width	1-leaf	ÖW	ÖW	$\text{ÖW} + 9$
	2-leaf	$\text{ÖW} / 2$	$\text{ÖW} / 2$	$\text{ÖW} / 2 + 9$
Glass height		FH - 90	FH - 90	FH - 85
Glass thickness		22	22	10, 12

Note:

max. leaf ratio width to height 1:4

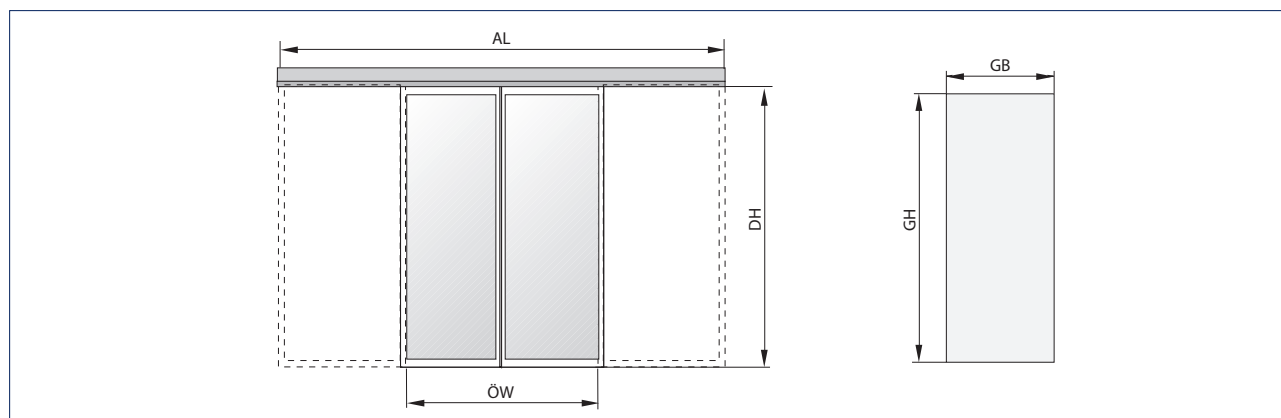

- AL = Drive length
- DH = Passage height
- GB = Glass width
- GH = Glass height
- ÖW = Opening width

With ISO/MONO glass fitting – without side parts

Drawing no. 70506-ep01

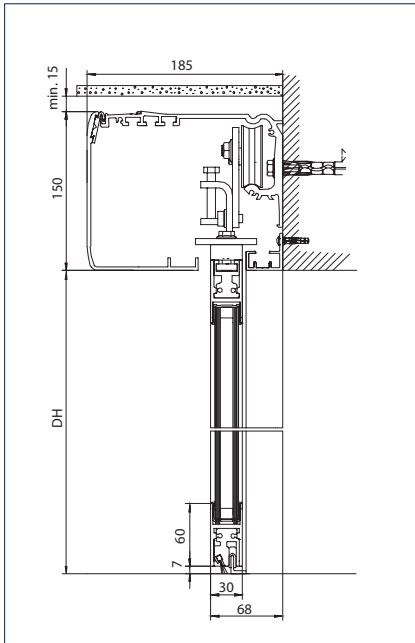

Floor guide: for floor mounting

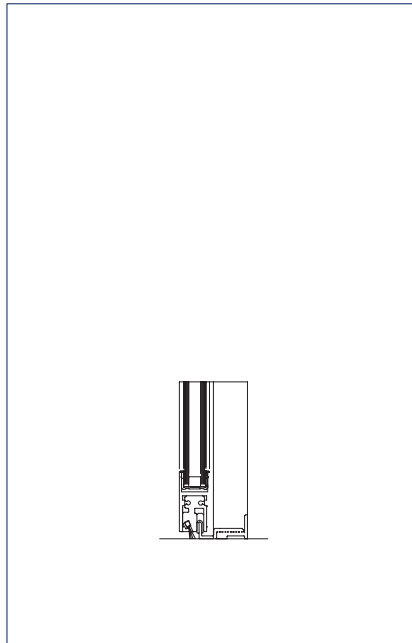

Floor guide: adjustable for wall assembly

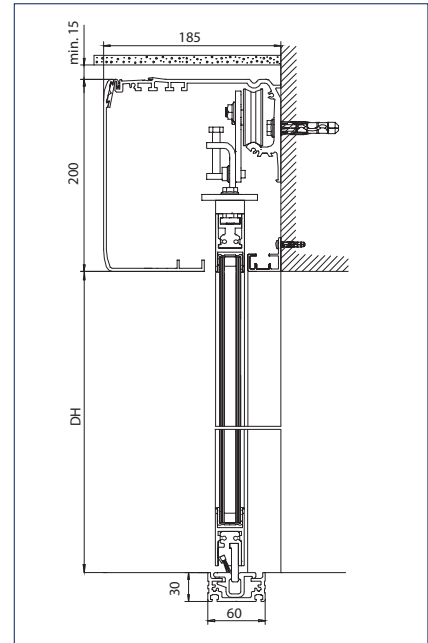

Floor guide: continuous

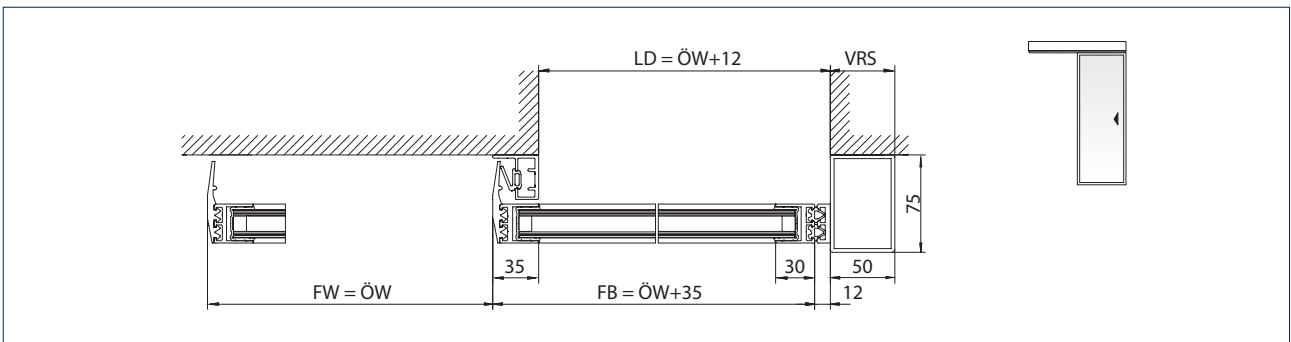

1-leaf door system

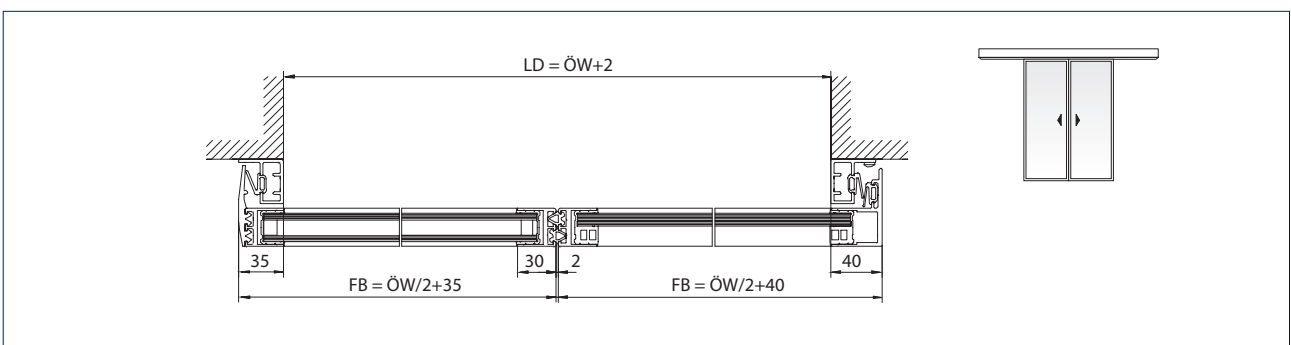

2-leaf door system

- LD = Clear passage
- FW = Travel path
- FB = Leaf width
- ÖW = Opening width
- VRS = Drive extension right
- DH = Passage height

GEZE POWERDRIVE PL

With ISO/MONO glass fitting – with side parts

Drawing no. 70506-ep02

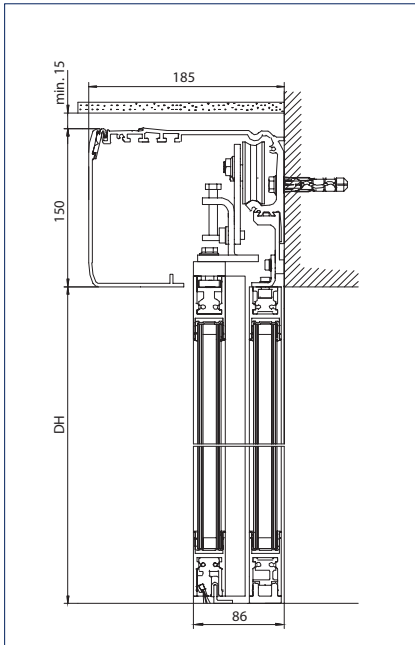

Door system with door leaf and side parts under drive

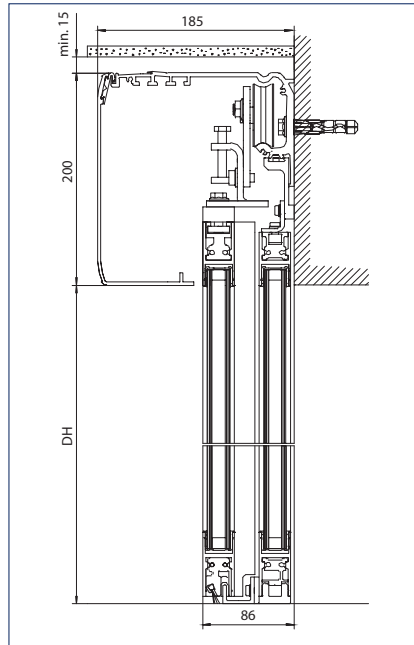

Door system with door leaf and side parts under drive

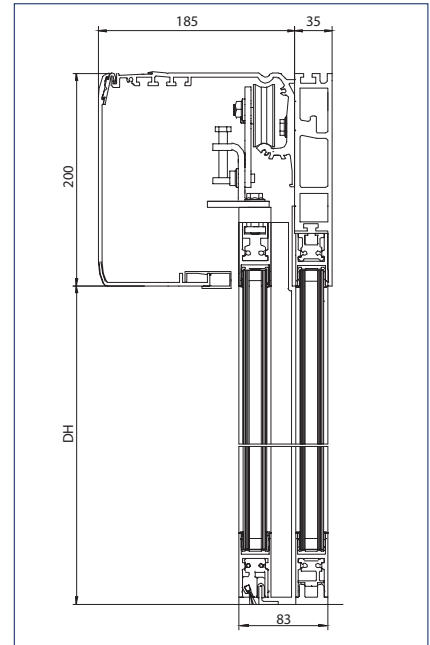

Door system with door leaf and side parts under carrier

Note: See installation drawing for area of application

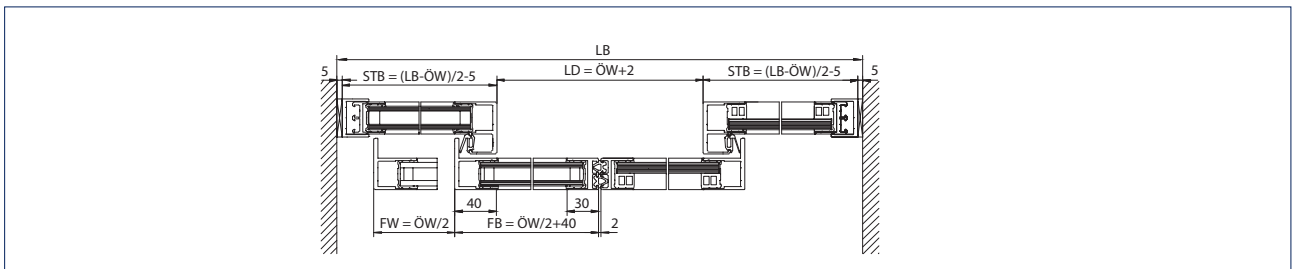

Installation: self-supporting installation

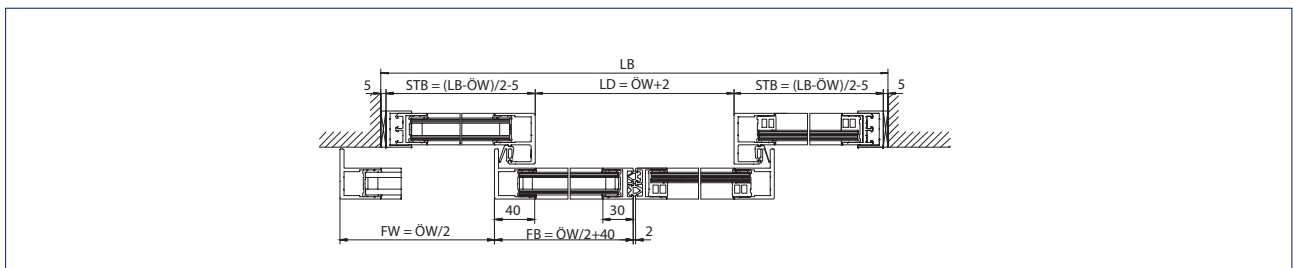

Installation: wall assembly with longer drive and carrier between the walls

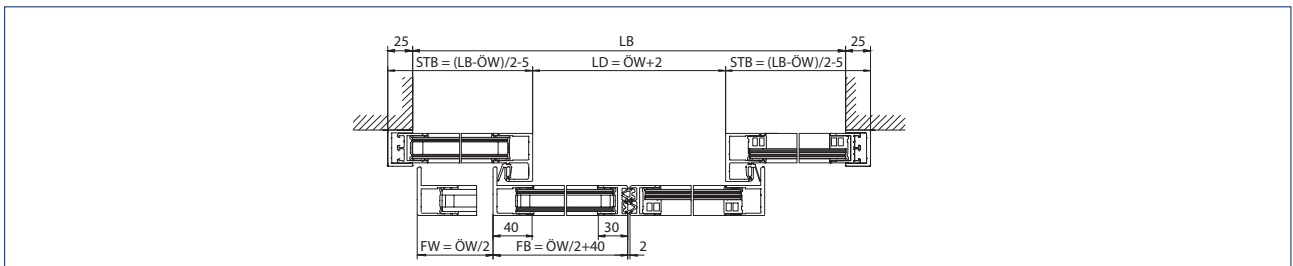

Installation: wall assembly

LB = Clear construction width

LD = Clear passage

FW = Travel path

FB = Leaf width

STB = Width of side parts

DH = Passage height

ÖW = Opening width

With protective leaf

Drawing no. 70499-ep05

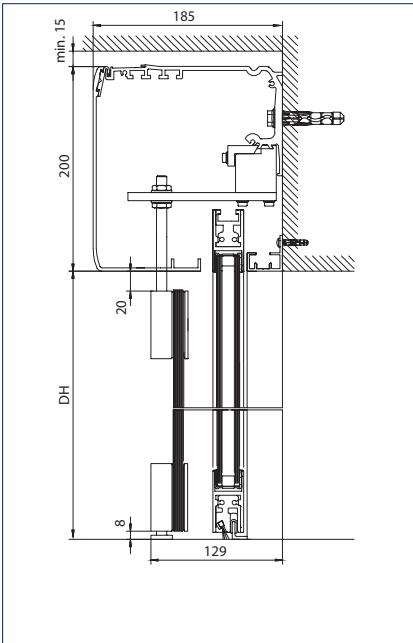

Protective leaf: drive installation
DH = Passage height

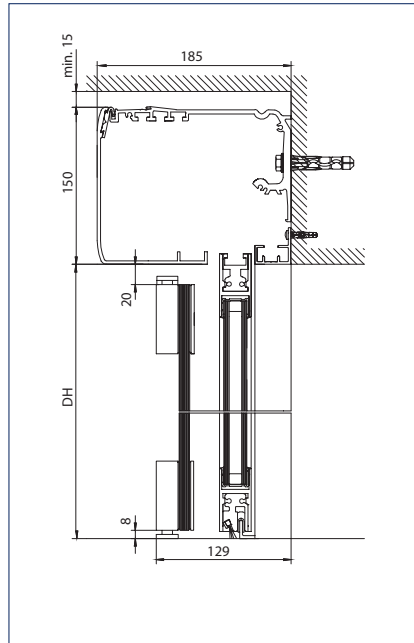

Protective leaf: wall assembly

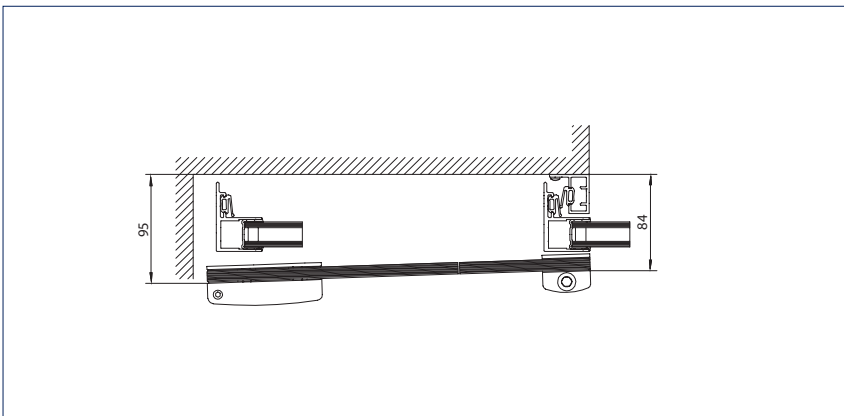

Protective leaf

GEZE POWERDRIVE PL

Toughened safety glass clamp fitting – without side part

Drawing no. 70506-ep03

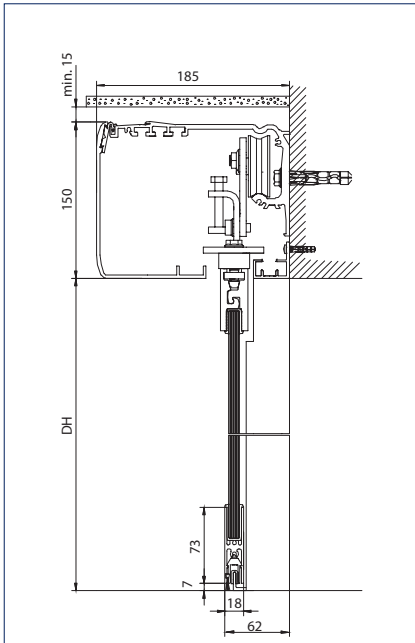

Floor guide: for floor mounting

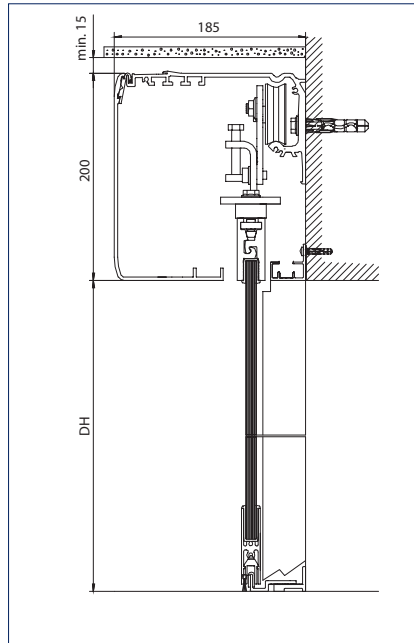

Floor guide: adjustable for wall assembly

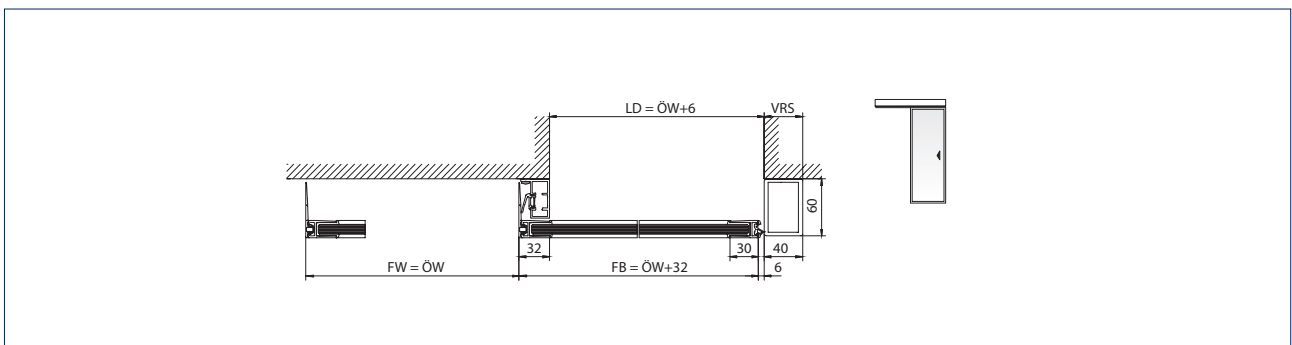

1-leaf door system

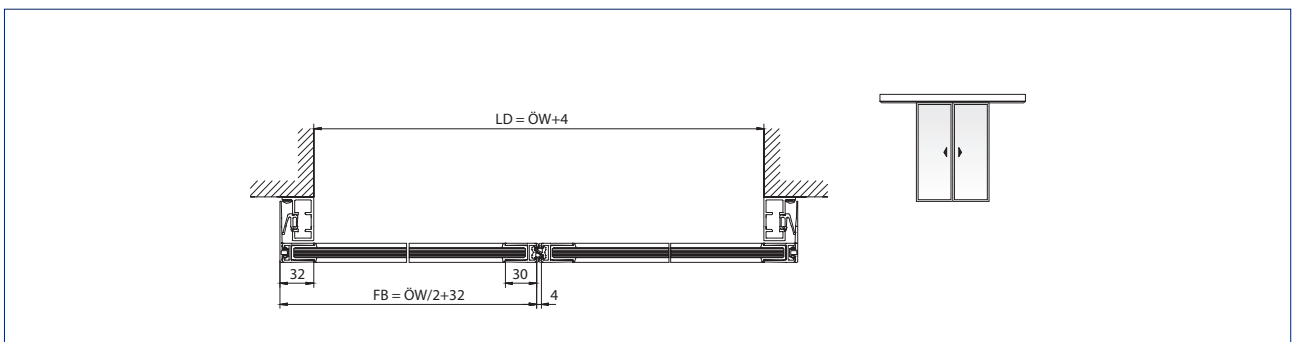

2-leaf door system

- LD = Clear passage
- FW = Travel path
- FB = Leaf width
- ÖW = Opening width
- VRS = Drive extension right
- DH = Passage height

Toughened safety glass clamp fitting – with side part

Drawing no. 70506-ep04

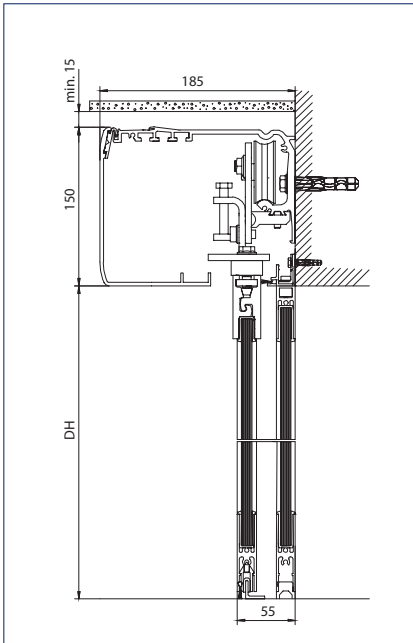

Door system with door leaf and side parts under drive

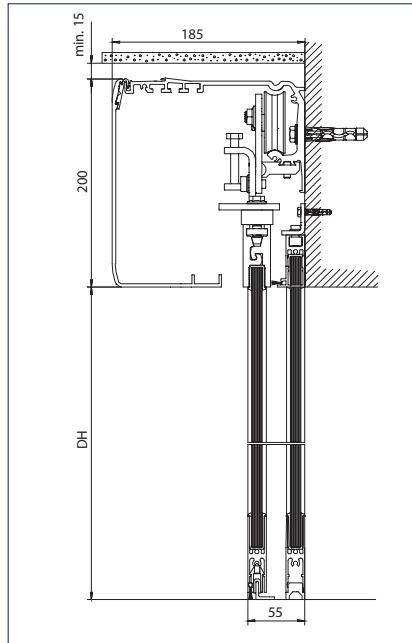

Door system with door leaf and side parts under drive

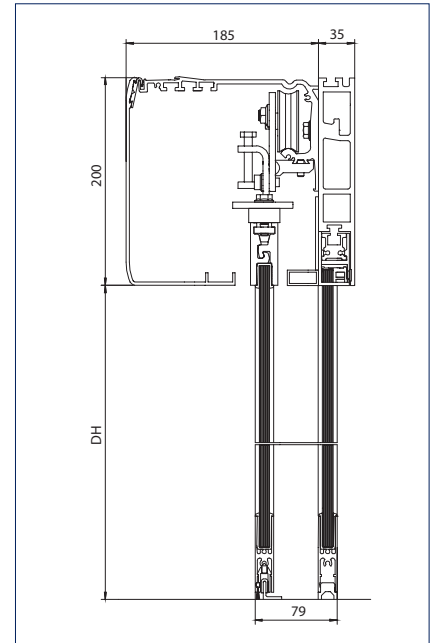

Door system with door leaf and side parts under carrier

Note: See installation drawing for area of application

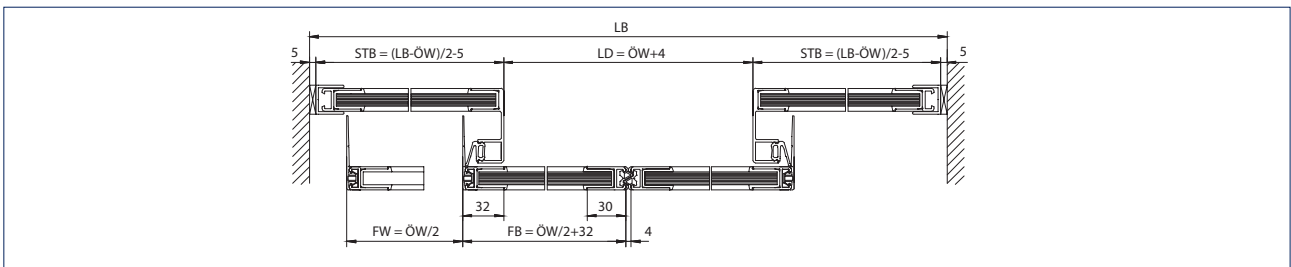

Installation: self-supporting installation

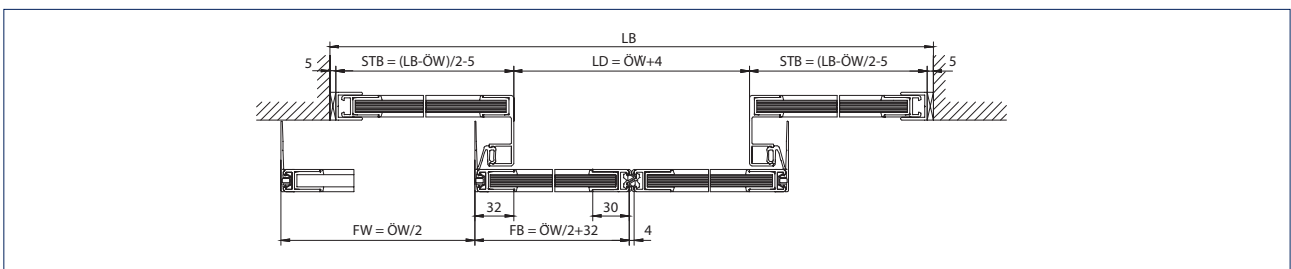

Installation: wall assembly with longer drive and carrier between the walls

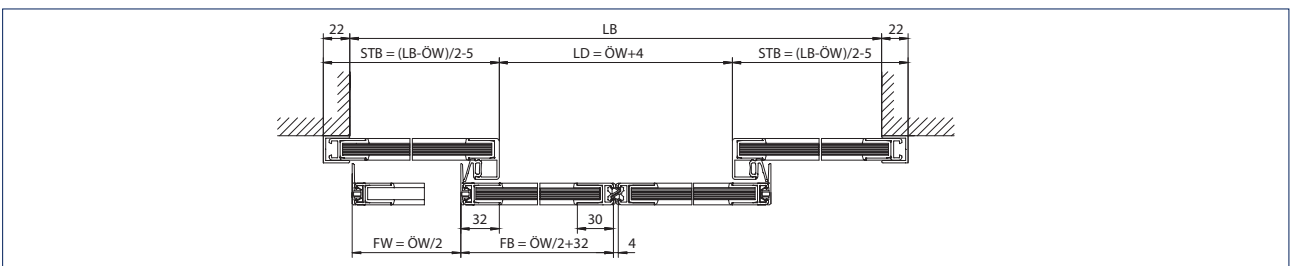

Installation: wall assembly with self-supporting carrier

LB = Clear construction width DH = Passage height
 STB = Width of side parts FB = Leaf width
 LD = Clear passage ÖW = Opening width
 FW = Travel path

GEZE POWERDRIVE PL

With on-site wooden leaf

Drawing no. 70506-ep09

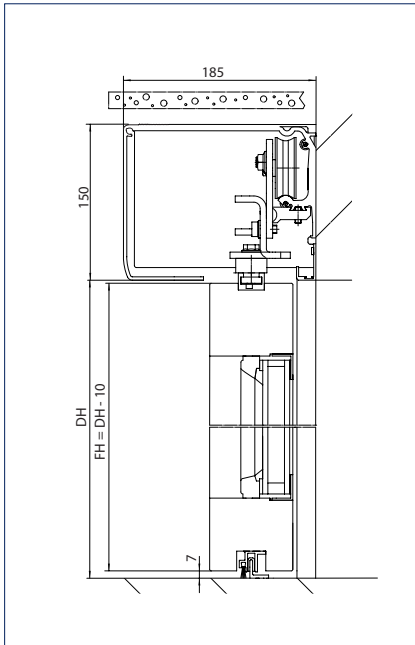

Version with 150 mm cover and floor guide for floor mounting

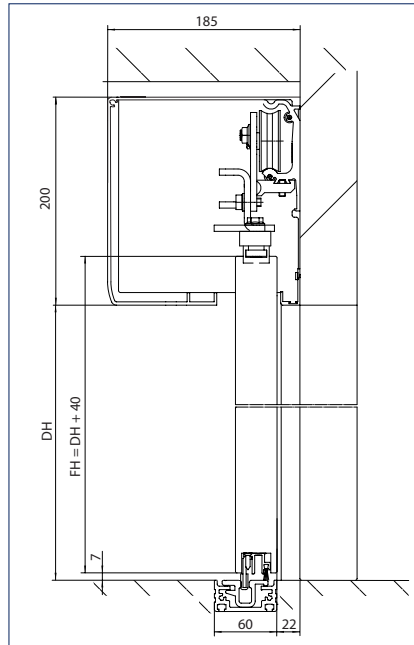

Version with 200 mm cover and continuous floor guide

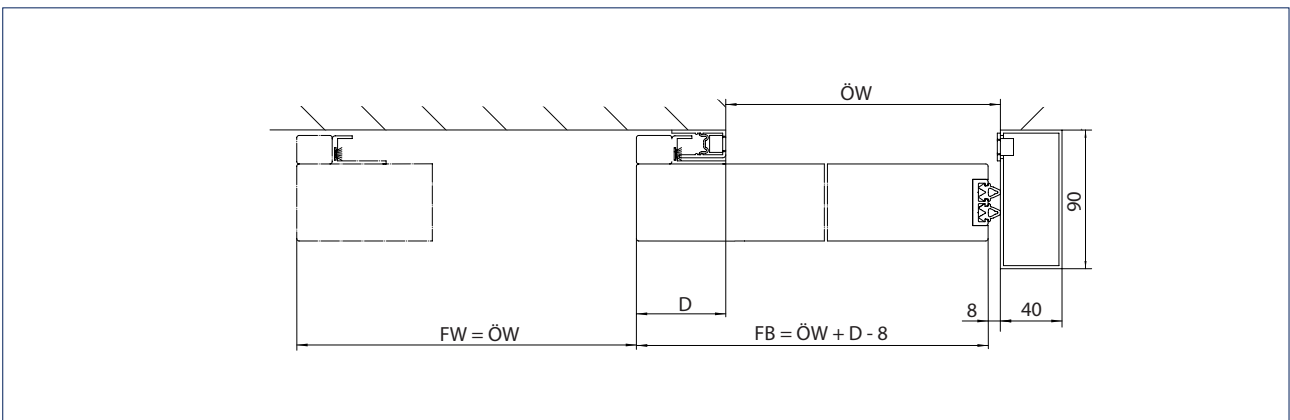

1-leaf door system

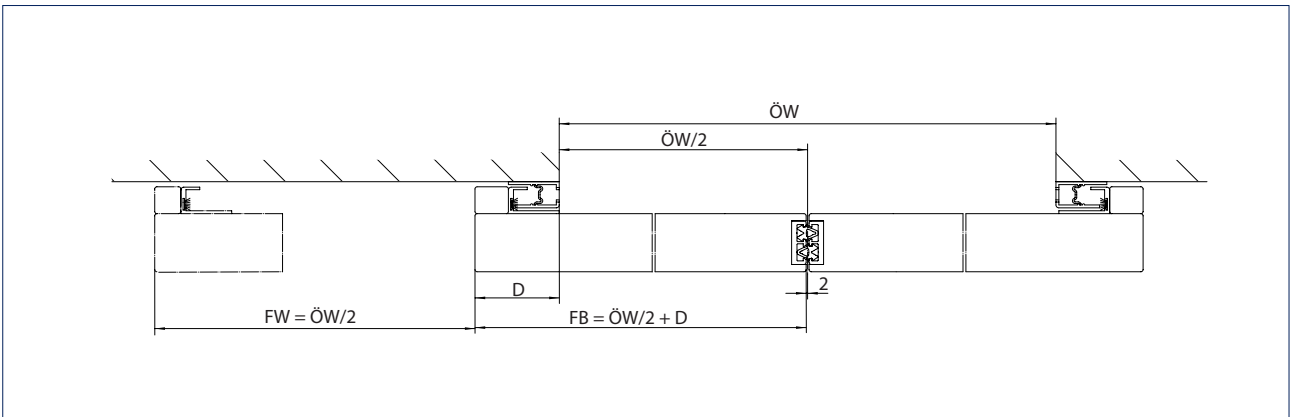

2-leaf door system

- D = Projection
- FB = Leaf width
- FW = Travel path
- ÖW = Opening width
- DH = Passage clearance
- FH = Leaf height

SPECIAL FUNCTIONS FOR EMERGENCY EXIT ROUTES

Special versions of sliding door systems

Solutions for special purposes

The GEZE Slimdrive SL drive is available in numerous special versions. These are always used when the standard version of the sliding door system is not suitable.

- **GEZE Slimdrive SLT:** Use in slim glass façades for 2- or 4-leaf doors.
- **GEZE Slimdrive SL RC2:** Sliding doors with burglar resistance in accordance with resistance class 2. Also optionally available as a version for escape and rescue routes (SL RC2-FR).
- **GEZE Slimdrive SL-BO:** This version is used in escape and rescue routes. In addition to the sliding function, these doors can be swung open using a turn-tilt fitting.
- **GEZE Slimdrive SL-RD:** Use as a smoke-proof sliding door thanks to flexible and heat-resistant seals at the perimeter.
- **GEZE Slimdrive SF:** Where space is restricted with maximum passage clearances, this version can be used to realise a folding door system.
- **GEZE Slimdrive SL-T30:** For applications where both fire-retardant doors in accordance with DIN 4102 and smoke-proof doors in accordance with DIN 18095 are required.
- **GEZE Slimdrive SLV:** This version can be used for corner sliding doors with angles between 90° and 270°.
- **GEZE Slimdrive SL inclined:** For the use of 2-leaf sliding doors in inclined glass façades with opening widths of up to 2500 mm.



Slimdrive SLT with IGG, Cafe Luitpold Munich, Germany (photo: Robert Sprang)

GEZE SLIMDRIVE SLT

GEZE Slimdrive SLT

Perfect integration even in the narrowest of glass façades

The GEZE Slimdrive SLT is used on 2 or 4-leaf telescopic sliding doors made of 22 mm insulated glass or frameless door leaves with concealed fittings (IGG). The Slimdrive SLT moves internal and external doors with leaf weights of up to a 320 kg reliably, inconspicuously and invisibly, thanks to the low overall height of only 7 cm. The drive makes opening widths of up to 3600 mm possible.



Technical data

Product features	SLT	SLT-FR
For 1-leaf door systems	-	-
For 2-leaf door systems	•	•
For 4-leaf door systems	•	•
Height	70 mm	
Depth	247 mm	
Leaf weight (max.) 2-leaf	80 kg	
Leaf weight (max.) 4-leaf	80 kg	
Opening width 2-leaf	1000 – 3000 mm	
Opening width 4-leaf	1600 – 3600 mm	
Temperature range	-15 – 50 °C	
Disconnection from mains	Main switch in the drive	
Opening speed (max.)	0.8 m/s	
Closing speed (max.)	0.8 m/s	
Hold-open time	0 – 60 S	
Adjustable opening and closing force (max.)	150 N	
Automatic adaptation to traffic flow	•	•
Automatic reversal when an obstacle is detected	•	•
Pharmacy opening	•	•
Interlocking door system function	•	-
Vestibule function	•	-
Automatic opening in the event of a power failure	adjustable	fitted as standard
Automatic closing in the event of a power failure	adjustable	not available
Function in the event of a power failure	adjustable for 30 min. / 30 cycles	open
Automatic opening in the event of a fault	not available	fitted as standard

• = YES
- = NOT AVAILABLE

Drive components



- 1 = Transformer
- 2 = Lock
- 3 = Control unit
- 4 = Battery
- 5 = Motor

Technical data	SLT	SLT-FR
Transformer	Ring core with fuse and main switch	
Voltage	230 V	
Frequency	50 – 60 Hz	
Capacity rating	150 W	
Lock	Toothed belt locking, electromagnetic, two-stage	
Roller carriage		
Door leaf adjustment vertical	7 mm	
Door leaf adjustment horizontal	7 mm	
Anti-tilt protection	Optional	
Self-cleaning	-	-
Control unit	DCU1-NT	DCU1-2M-NT
With fault memory	●	●
With memory for statistical data	●	●
Software update possible	●	●
Optional bus interface	●	●
Connection for fire alarm system	●	●
Power supply for peripherals	●	●
Programmable inputs	3 pc.	
Programmable outputs	2 pc.	
Battery	NiCd, 24 V, 700 mAh	
Motor	Gear motor	Double gear motor
Torque	400 Ncm	

- = YES
- = NOT AVAILABLE

GEZE SLIMDRIVE SLT

Fitting versions

Fittings	SLT
ISO glass fine-framed	●
MONO glass fine-framed	-
ESG clamping profile	-
All-glass system (GGS)	-
Integrated all-glass system (IGG)	●
Frame leaf (provided by customer)	-
Wooden leaf (provided by customer)	-

- = YES
- = NOT AVAILABLE



Robert Bosch Hospital, Stuttgart, Germany (photo: Nikolaus Grünwald)

Calculation of the drive length AL in mm*

Slimdrive SLT		Slimdrive SLT-FR		
	Opening width (ÖW)	Drive length (AL)	Opening width (ÖW)	Drive length (AL)
4-leaf	1600 - 1999	$\ddot{O}W + 1180$	1600 - 1999	$\ddot{O}W + 1180$
	2000 - 3600	$1.5 \times \ddot{O}W + 150$	2000 - 3600	$1.5 \times \ddot{O}W + 150$
2-leaf, closing on the right	1000 - 1360	$\ddot{O}W + 770$	1000 - 1560	$\ddot{O}W + 870$
	1360 - 3000	$1.5 \times \ddot{O}W + 90$	1560 - 3000	$1.5 \times \ddot{O}W + 90$
2-leaf, closing on the left	1000 - 1460	$\ddot{O}W + 780$	1000 - 1660	$\ddot{O}W + 880$
	1460 - 3000	$1.5 \times \ddot{O}W + 50$	1660 - 3000	$1.5 \times \ddot{O}W + 50$

* Minimum overall length of the system with ISO glass profile system

Note:

Opening widths of escape route sliding doors < 1000 mm are only permitted in exceptional cases.
 A continuous floor guide is generally recommended for outdoor systems.
 The minimum opening widths depend on the requirements of building law.

Calculation of leaf and glass dimensions in mm

depending on the opening width and passage height			
		Internal leaf	External leaf
Leaf width	2-leaf	$\ddot{O}W / 2 + 40$	
	4-leaf	$\ddot{O}W / 4 + 40$	
Leaf height	2 or 4-leaf	$DH - 17$	
Glass width	2-leaf	$\ddot{O}W / 2$	$\ddot{O}W / 2 - 10$
	4-leaf	$\ddot{O}W / 4$	$\ddot{O}W / 4 - 10$
Glass height	2 or 4-leaf	$FH - 90$	$FH - 90$
Glass thickness		22	22

Note:

max. leaf ratio width to height 1:4 or 1:5 in the case of 4-leaf systems, ÖW 1600 - 2000 mm

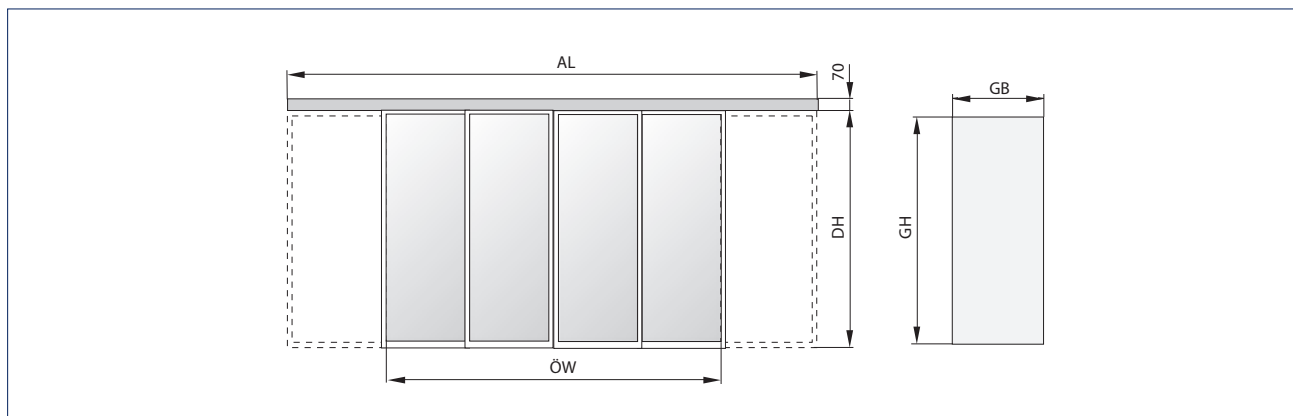

- AL = Drive length
- DH = Passage height
- GB = Glass width
- GH = Glass height
- ÖW = Opening width

GEZE SLIMDRIVE SLT

Self-supporting beam

2-leaf

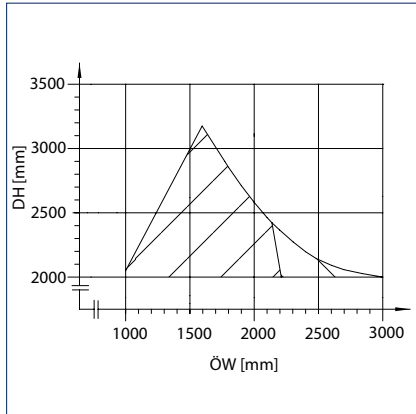

DH = Passage height
ÖW = Opening width

4-leaf

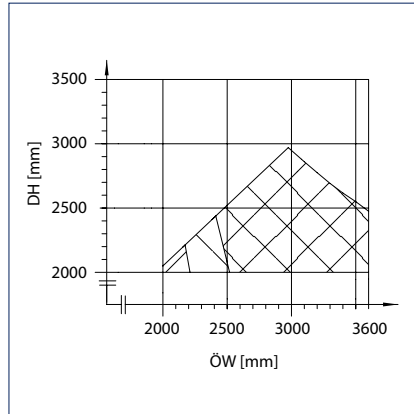

DH = Passage height
ÖW = Opening width

Profiles

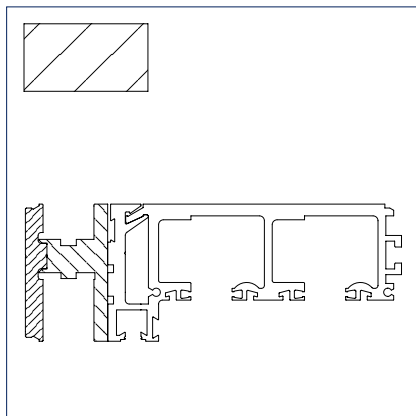

Standard carrier SL

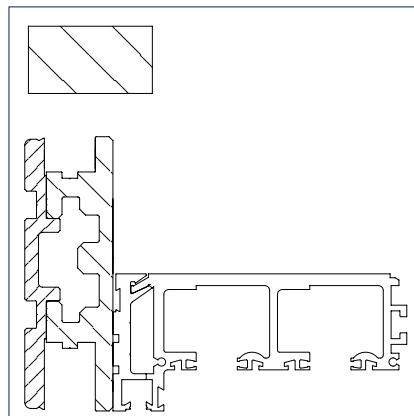

Additional carrier EC/SL

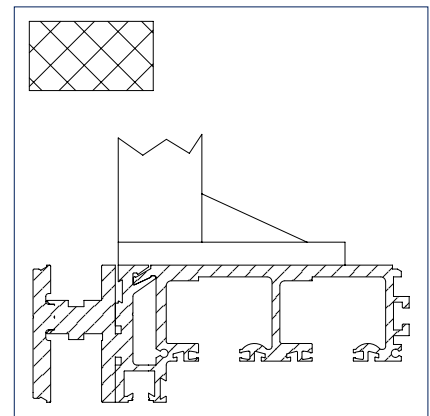

Carrier and track additionally suspended from the ceiling

With ISO/MONO glass fitting – without side part

Drawing no. 70487-ep01

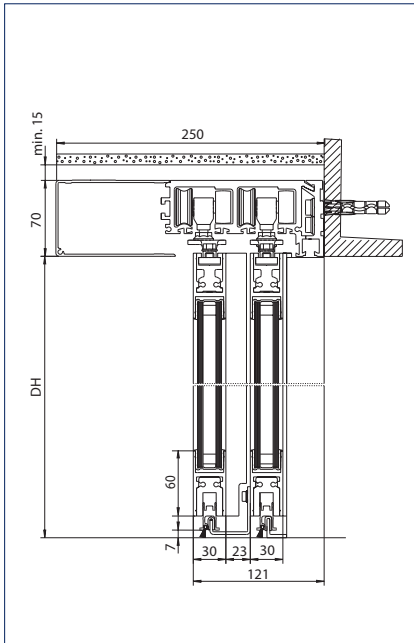

Floor guide: for floor mounting

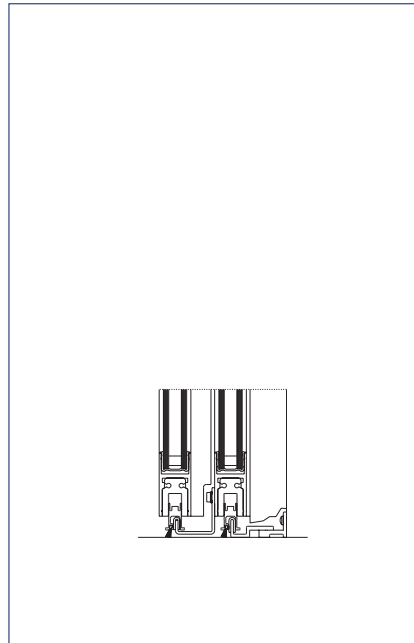

Floor guide: adjustable for wall assembly



Floor guide: continuous

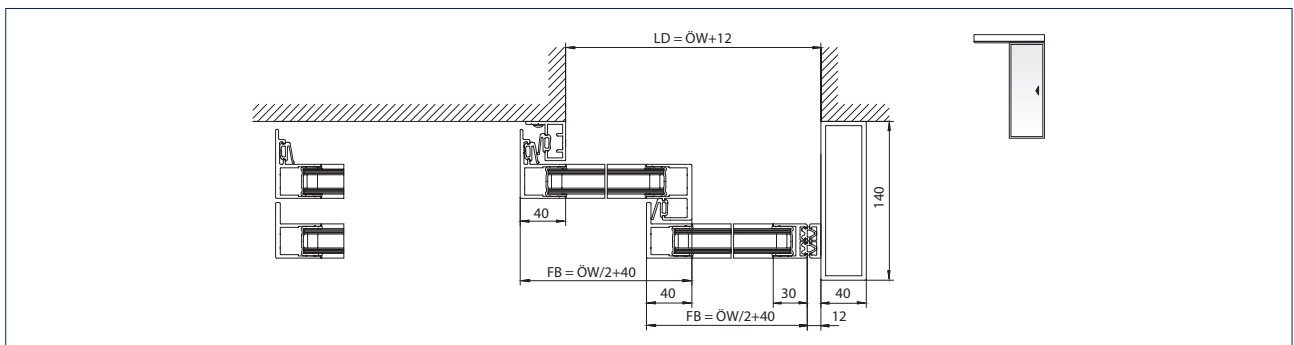

1-leaf door system

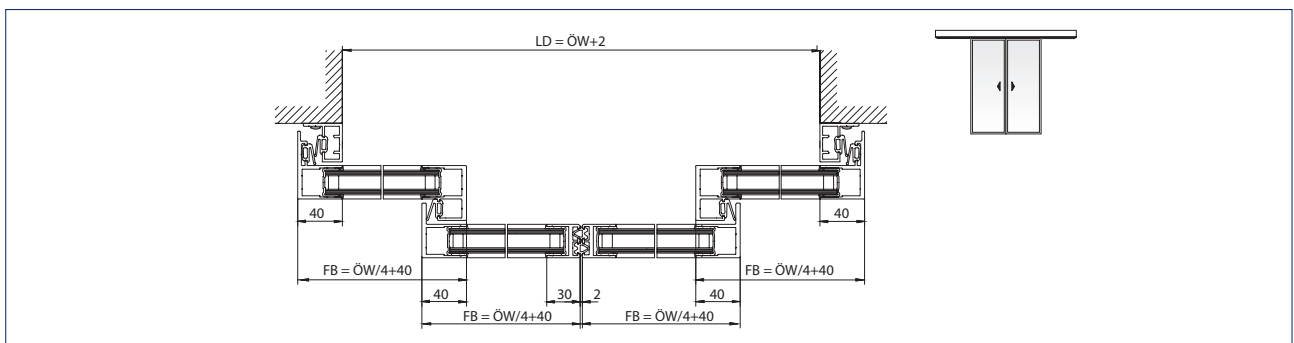

2-leaf door system

LD = Clear passage
 FB = Leaf width
 ÖW = Opening width
 DH = Passage height

GEZE SLIMDRIVE SLT

With ISO/MONO glass fitting – with side part

Drawing no. 70717-ep02 + 70717-ep04

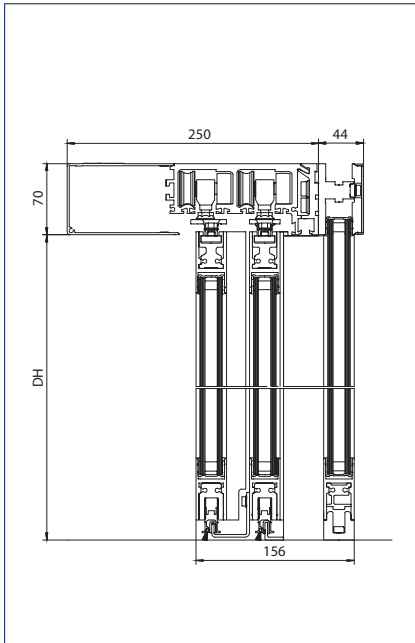

Low self-supporting beam

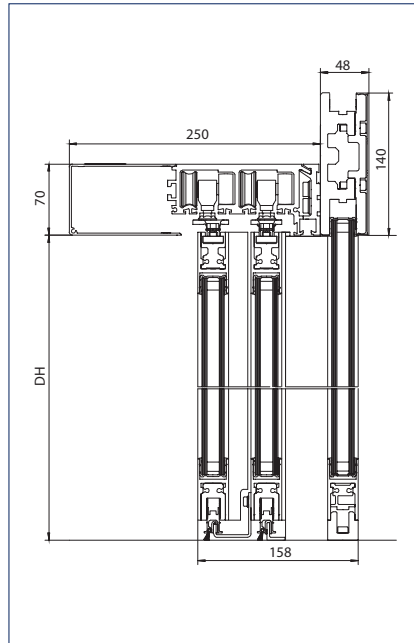

High self-supporting beam

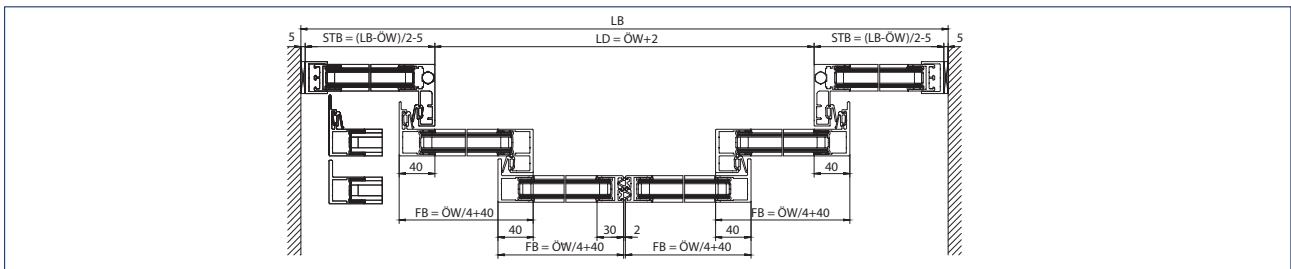

Installation: self-supporting installation

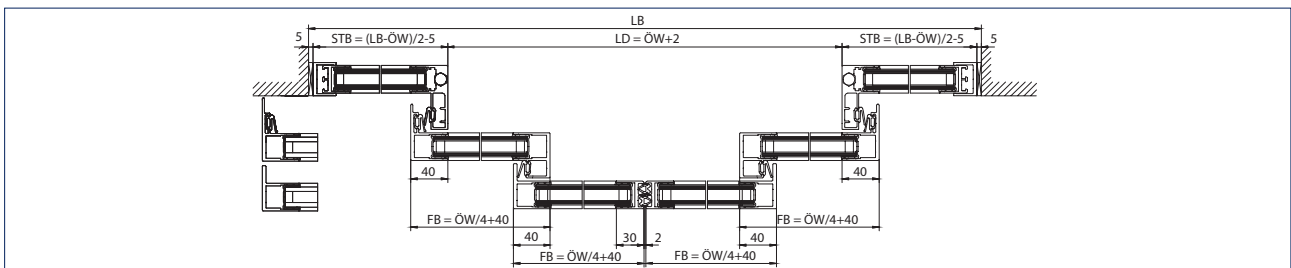

Installation: wall assembly with longer drive and carrier between the walls

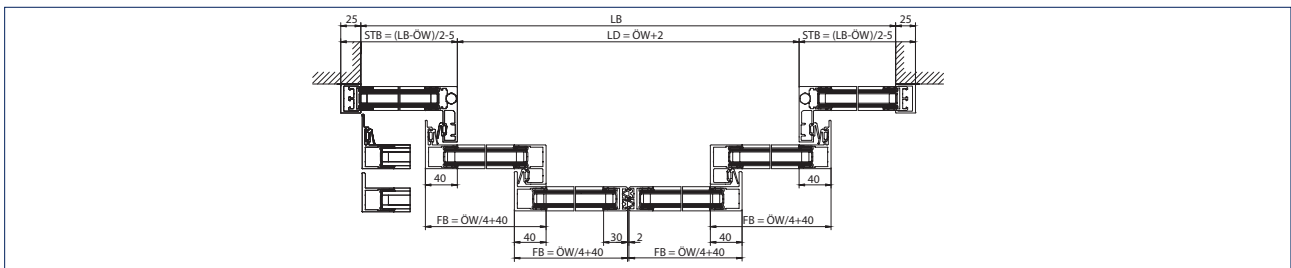

Installation: wall assembly

- LB = Clear construction width
- STB = Width of side parts
- LD = Clear passage
- FB = Leaf width
- ÖW = Opening width
- DH = Passage height

Note: See installation drawing for area of application

With safety leaf

Drawing no. 70487-ep01

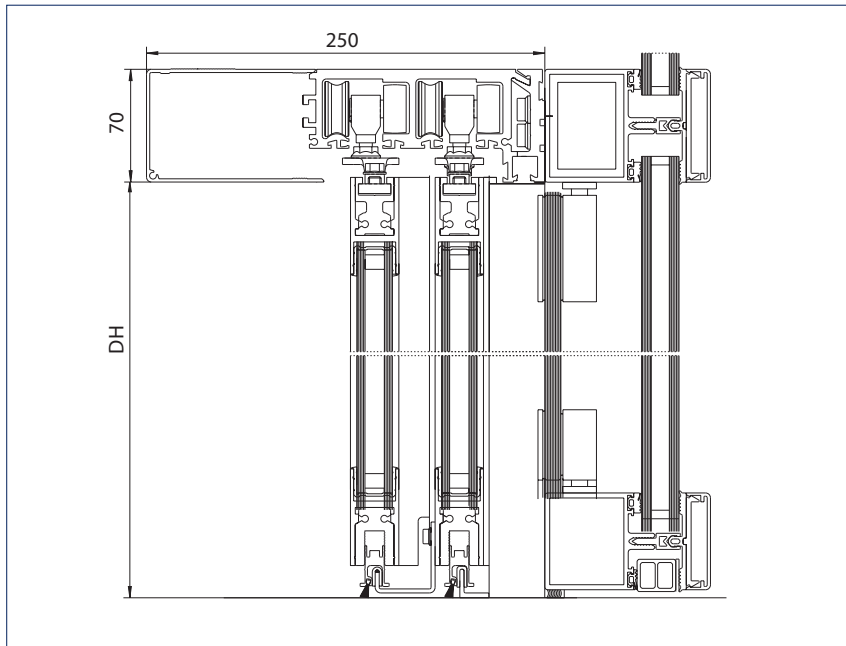

Installation: on post-rail construction with safety leaf
DH = Passage height

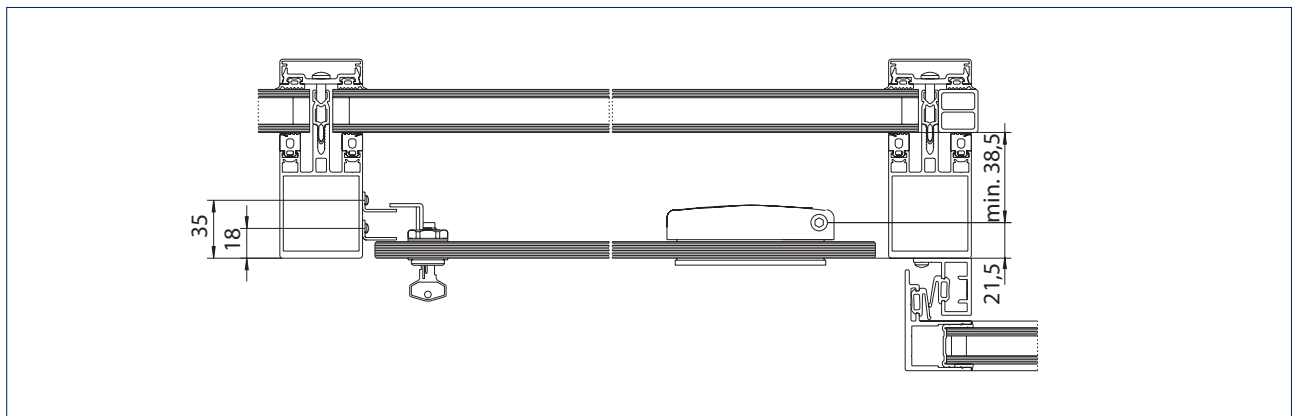

Installation: on post-rail construction with safety leaf

Note: See installation drawing for area of application

GEZE SLIMDRIVE SLT

With integrated all-glass system (IGG) – with and without side parts

Drawing no. 70487-ep07

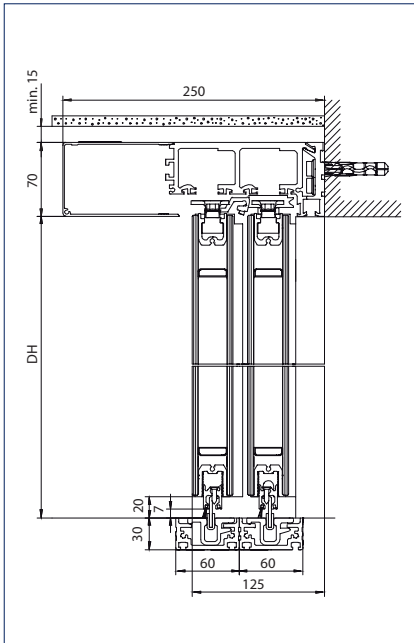

Version with leaf

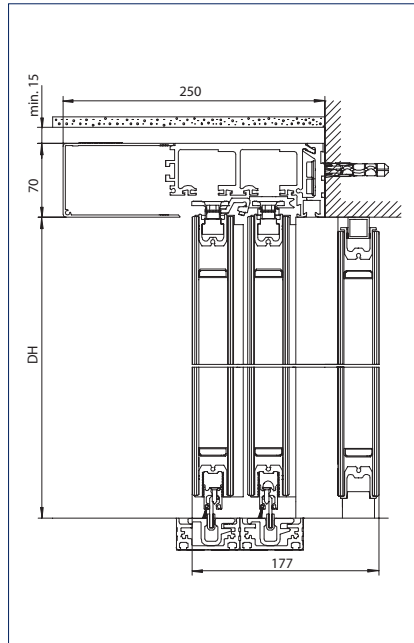

Version with leaf and side parts

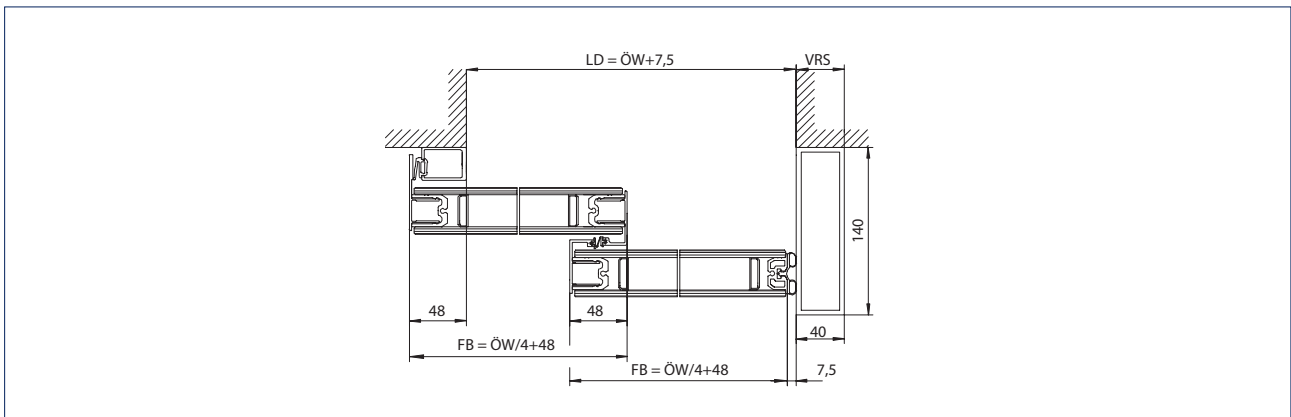

2-leaf door system

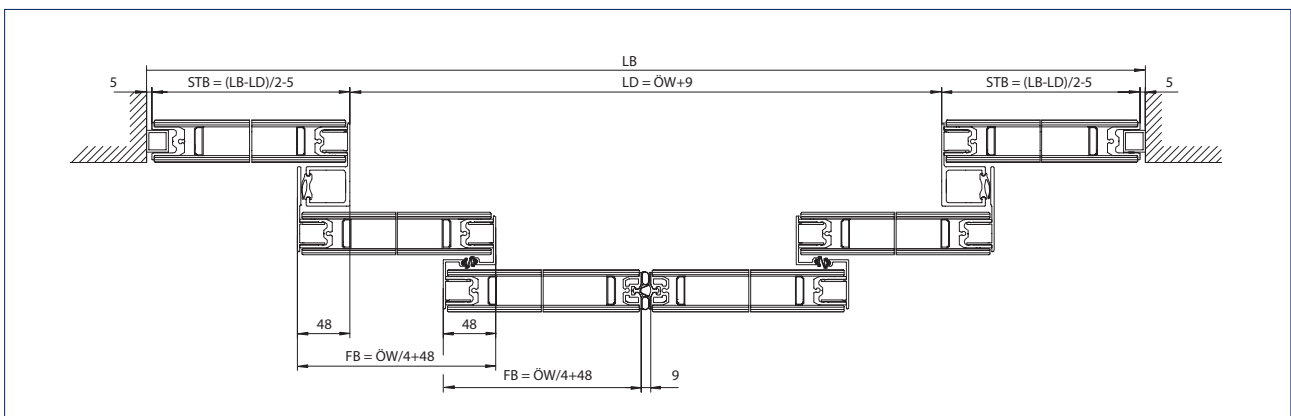

4-leaf door system

FB = Leaf width
 ÖW = Opening width
 VRS = Drive extension right
 DH = Passage height

LB = Clear construction width
 STB = Width of side parts
 LD = Clear passage

GEZE Slimdrive SL RC2

Sliding doors with burglar resistance in accordance with resistance class 2 (RC2)

The burglar-resistant automatic linear sliding door system GEZE Slimdrive SL RC2 and the escape and rescue route version SL-FR RC2 makes burglars' lives difficult. It was especially developed for building entrances with increased safety requirements. Both versions have been tested in accordance with component resistance class 2 (RC2) in compliance with DIN V ENV 1627 to 1630. This means that they can withstand attempts to be levered open using tools of the RC2 class such as screwdrivers, pliers and wedges, and can withstand static and dynamic loads. Opportunists are stopped effectively and security companies gain response time. RC2 sliding doors are particularly used in banks, pharmacies, jewellers, petrol stations and IT rooms. The burglar-resistant function RC2 is only enabled in „NIGHT“ mode of operation. In „NIGHT“ mode of operation the door does not fulfil any escape route requirements. It is necessary to ensure that there is nobody in the building or that sufficient other escape route doors are available.



Hygro Grand Centre, Zagreb, Croatia (photo: Robert Les)

GEZE SLIMDRIVE SL RC2

Calculation of the drive length AL in mm*

	Slimdrive SL RC 2		Slimdrive SL-FR RC 2**	
	Opening width (ÖW)	Drive length (AL)	Opening width (ÖW)	Drive length (AL)
2-leaf	900-1000	$\ddot{O}W + 1100$	900-1000	$\ddot{O}W + 1100$
	1000-3000	$2 \times \ddot{O}W + 100$	1000-3000	$2 \times \ddot{O}W + 100$
1-leaf closing on the right	800 - 3000	$2 \times \ddot{O}W + 120$	800 - 870	$\ddot{O}W + 990$
			870 - 3000	$2 \times \ddot{O}W + 120$
1-leaf closing on the left	800-3000	$2 \times \ddot{O}W + 120$	800-820	$\ddot{O}W + 940$
			820-3000	$2 \times \ddot{O}W + 120$

* Minimum overall length of the complete system with ISO glass profile system

** Request drawing for FR variations (FR-RWS, FR-LL)!

Note:

Opening widths of escape route sliding doors < 1000 mm are only permitted in exceptional cases.

The minimum opening widths depend on the requirements of building law.

Calculation of leaf and glass dimensions in mm (ISO glass profile system)

ISO glass (in accordance with RC2)		
Leaf width	1-leaf	$\ddot{O}W / + 40$
	2-leaf	$\ddot{O}W / 2 + 40$
Leaf height	1-leaf / 2-leaf	DH - 17
Glass width	1-leaf	$\ddot{O}W - 20$
	2-leaf	$\ddot{O}W / 2 - 20$
Glass height	1-leaf / 2-leaf	FH - 90
Glass thickness	1-leaf / 2-leaf	max. 23.5

Note:

max. leaf ratio width to height 1:4

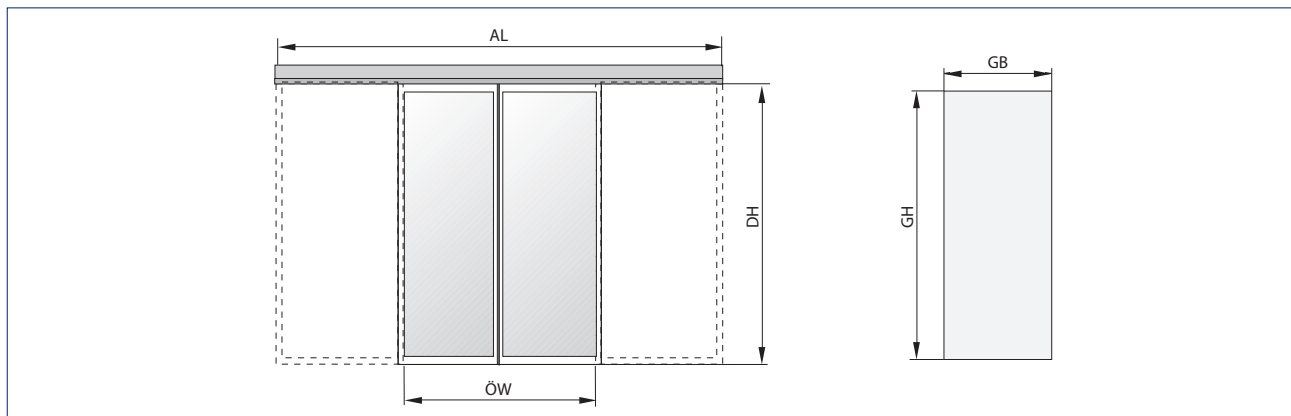

AL = Drive length

DH = Passage height

GB = Glass width

GH = Glass height

ÖW = Opening width

Note:

The burglar-resistant function RC2 is only enabled in „NIGHT“ mode of operation. In „NIGHT“ mode of operation the door does not fulfil any escape route requirements. It is necessary to ensure that there is nobody in the building or that sufficient other escape route doors are available.

Area of application

1-leaf and 2-leaf

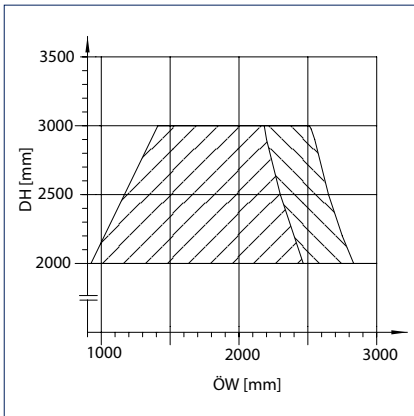

DH = Passage height
ÖW = Opening width

Profiles

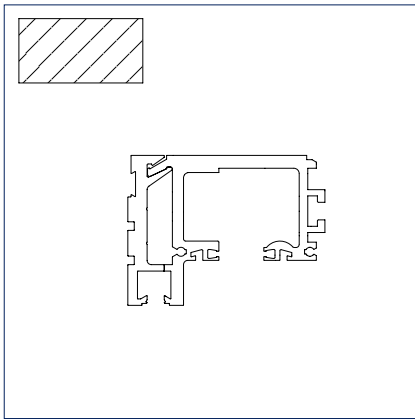

Standard area of application

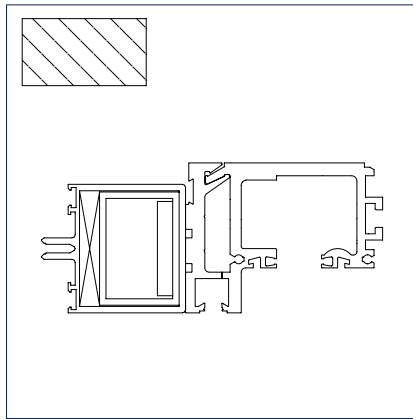

Extended application area with bolt reinforcement (steel tube) in the passage area (on site).

Note:

A continuous floor guide (on request) is recommended for installation situations with high wind loads (from wind force 5).
Version with continuous floor guide based on RC2.

GEZE SLIMDRIVE SL RC2

With ISO/MONO glass fitting – without side part

Drawing no. 70484-ep-46/47

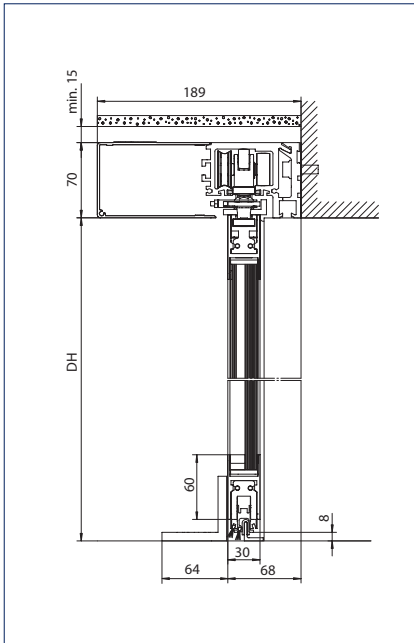

Floor guide: with reinforced supporting bracket at individual points

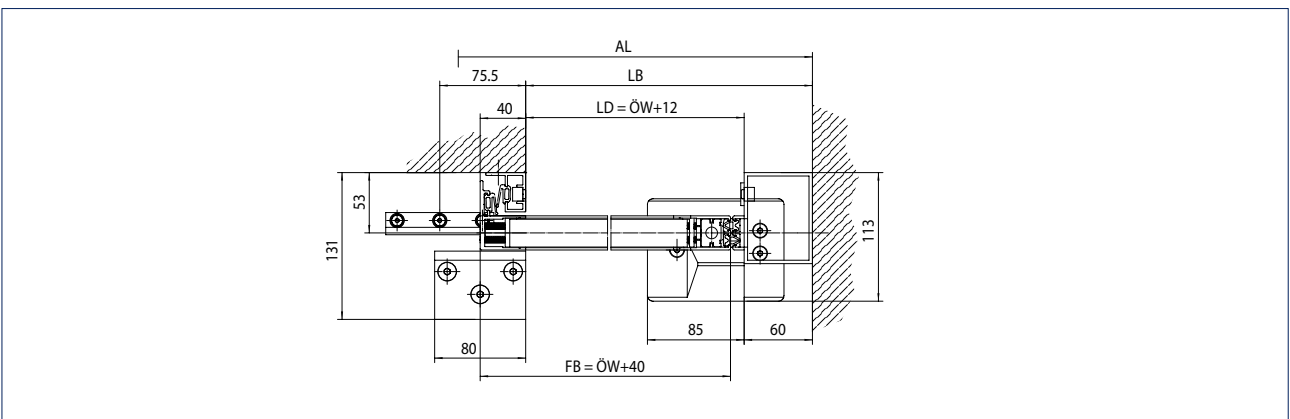

1-leaf door system

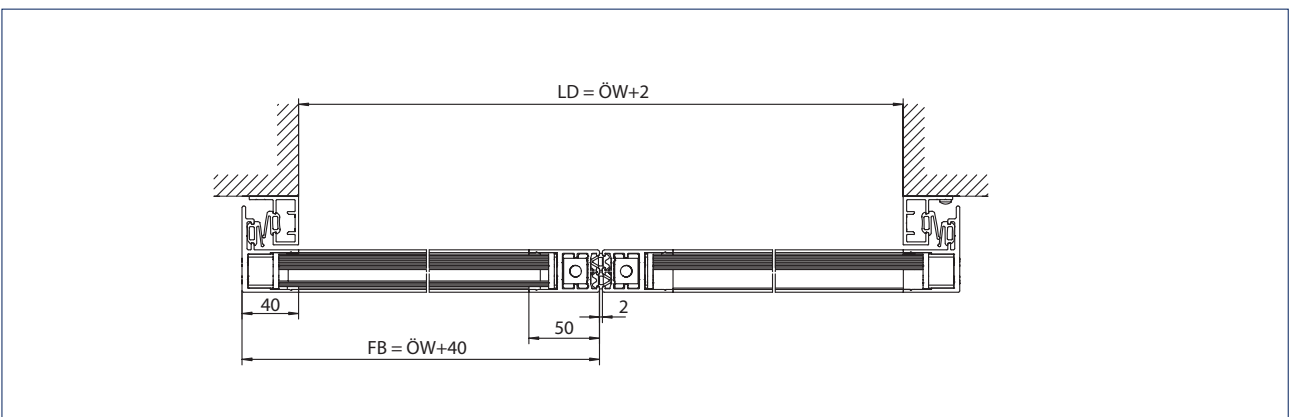

2-leaf door system

AL = Drive length
 LB = Clear construction width
 DH = Passage height

LD = Clear passage
 FB = Leaf width
 ÖW = Opening width

With ISO/MONO glass fitting – with side part

Drawing no. 70484-ep-46/47

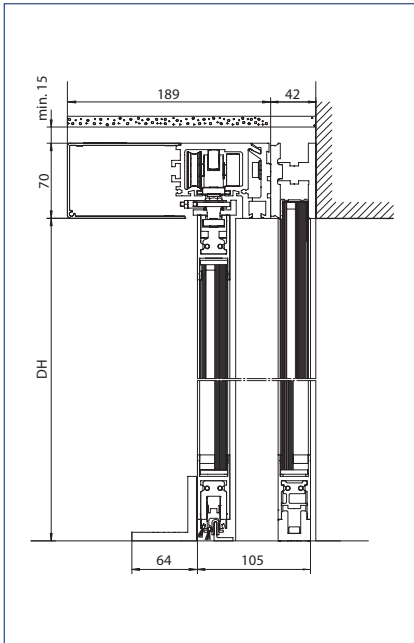

Floor guide: with reinforced supporting bracket at individual points

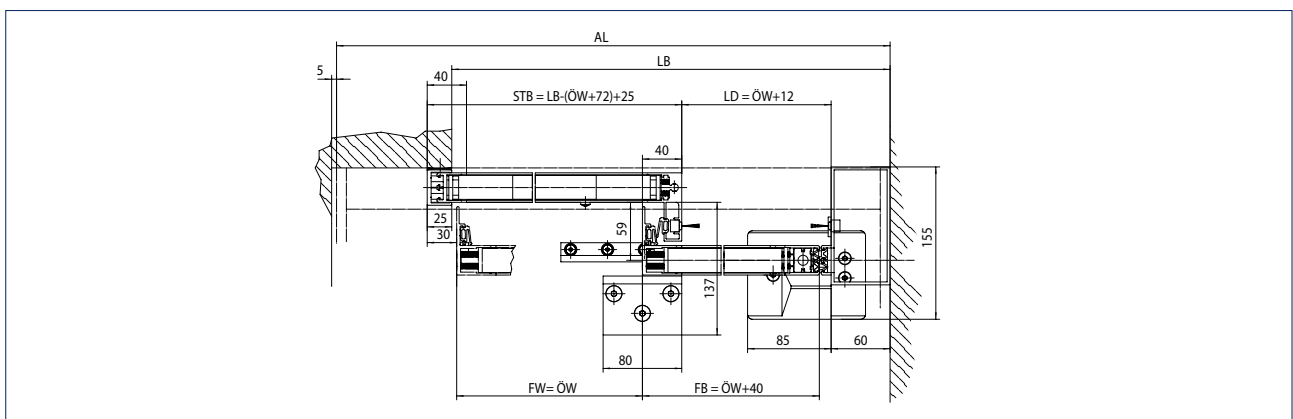

1-leaf door system

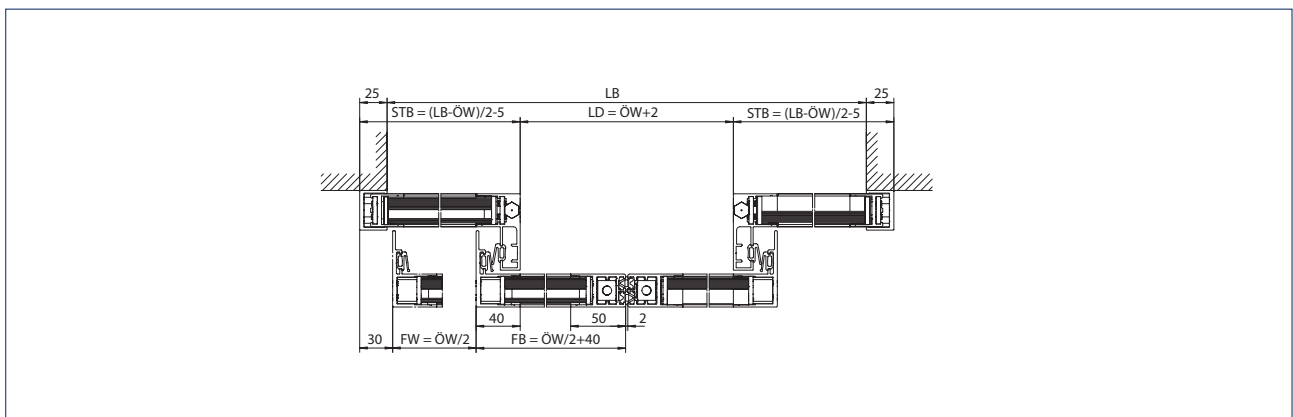

Installation: wall assembly

- | | |
|---------------------|-------------------------------|
| AL = Drive length | LB = Clear construction width |
| FB = Leaf width | LD = Clear passage |
| FW = Travel path | ÖW = Opening width |
| DH = Passage height | STB = Width of side parts |

Note: See installation drawing for area of application

GEZE SLIMDRIVE SL-BO

GEZE Slimdrive SL-BO

Emergency opening by swinging leaves and side parts open

GEZE sliding doors with break-out function are used on escape and rescue routes. The BO function allows the leaves to be swung open in the direction of emergency exit – as a sliding door system with a turn-tilt fitting, so to speak. Sliding doors with BO function have swing-out side elements and are available for 1 or 2-leaf door systems. Doors with escape route requirements are used in regions where redundant drives are not accepted. BO sliding doors are used in entrance areas where a large opening width is required, e.g. in car dealerships.



Hörsaalzentrum Klinikum rechts der Isar, Munich, Germany (photo: Robert Sprang)

With ISO/MONO glass fitting

Drawing no. 70485-ep51

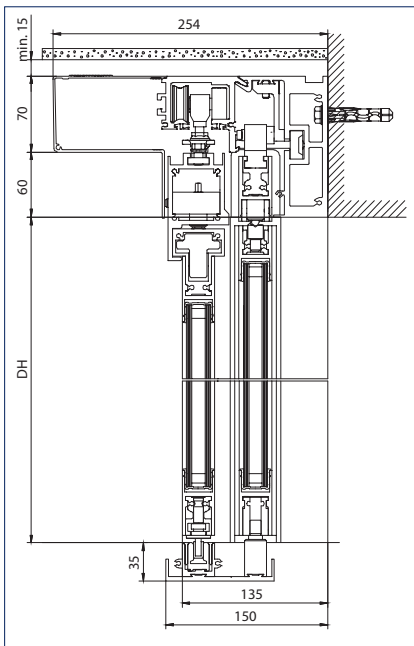

Door system with door leaf and side parts

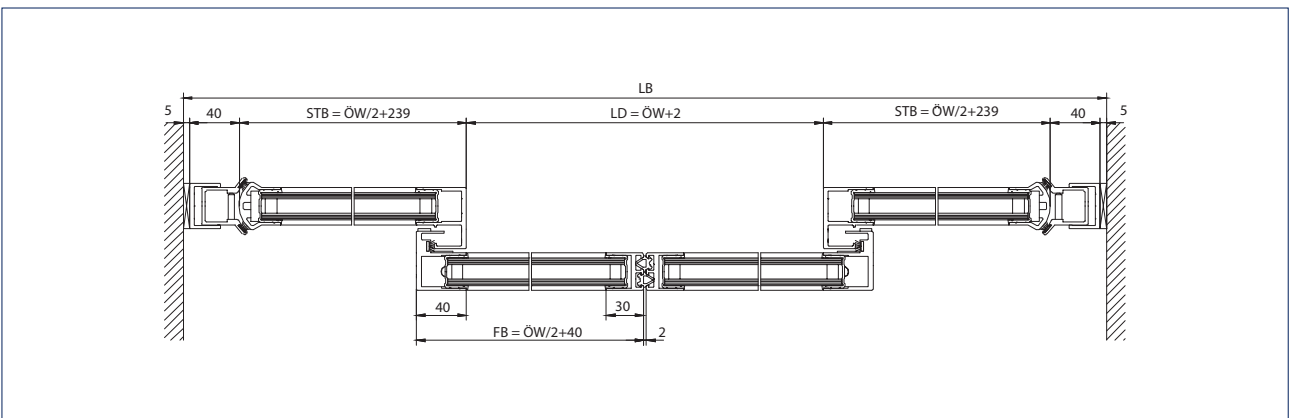

Installation: self-supporting installation

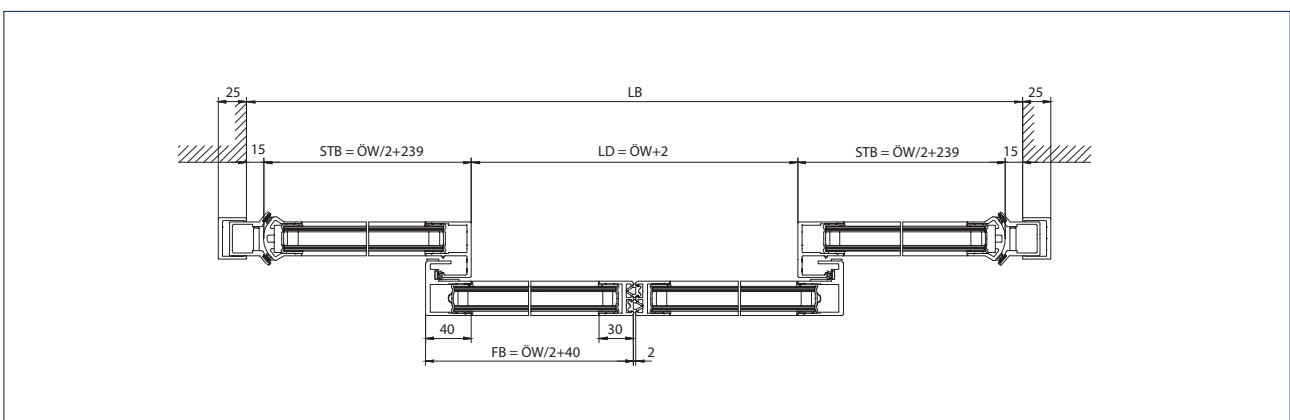

Installation: wall assembly

LB = Clear construction width
 STB = Width of side parts
 LD = Clear passage

FB = Leaf width
 ÖW = Opening width
 DH = Passage height

GEZE SLIMDRIVE SL-RD

GEZE Slimdrive SL-RD

Enhanced safety thanks to smoke-proof sliding doors (RD)

Smoke-proof sliding doors from GEZE meet all smoke protection requirements and allow various design possibilities, thanks, among others, to the 7 cm drive height of the Slimdrive product line. This sliding door system is made up of the drive and the sophisticated smoke-proof profile system. The continuous floor guide and flexible, heat-resistant seals at the perimeter guarantee smoke-proofing. In the event of a fire, release is via a smoke detector or an external fire detector system.



Andels Hotel, Berlin, Germany (photo: Stefan Dauth)

With ISO/MONO glass fitting

Drawing no. 70484-ep39

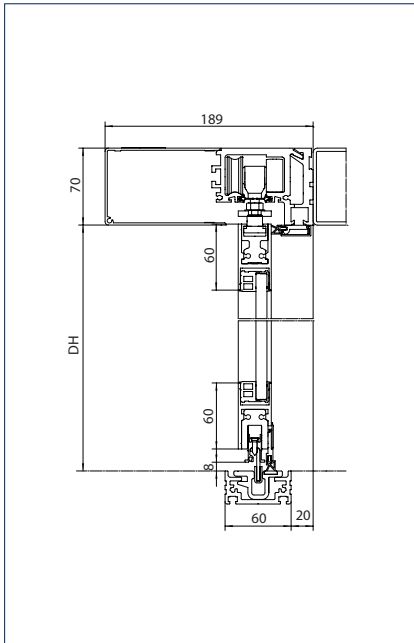

Drive on bolt profile

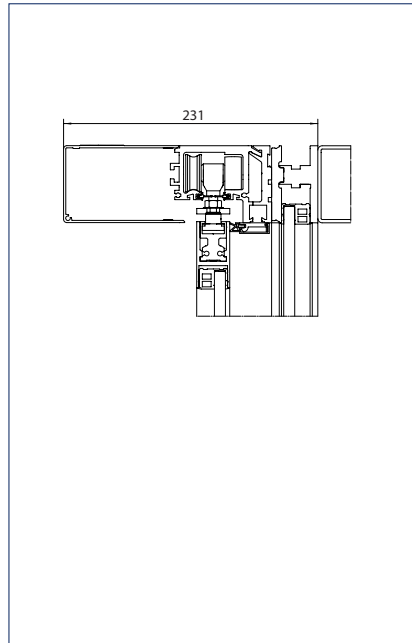

Drive with side parts on bolt profile

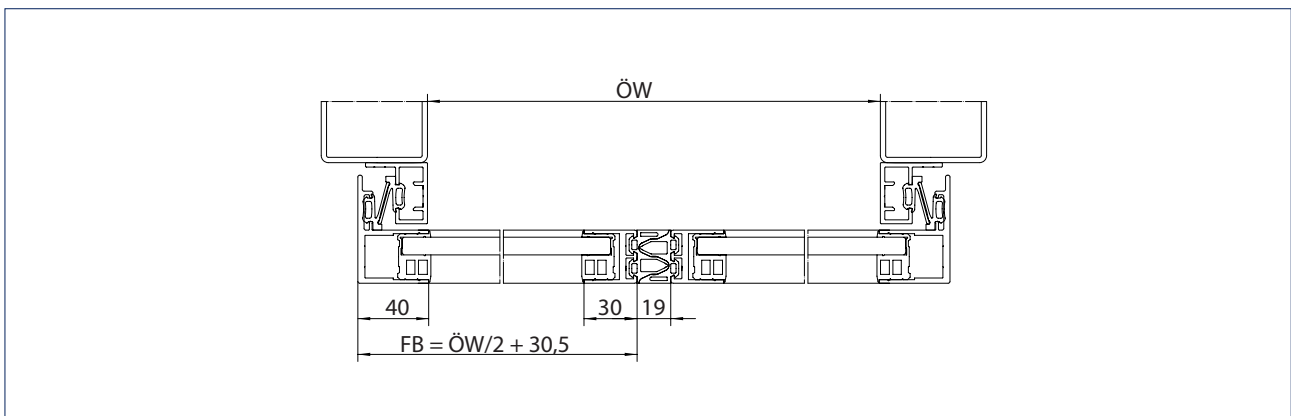

2-leaf door system

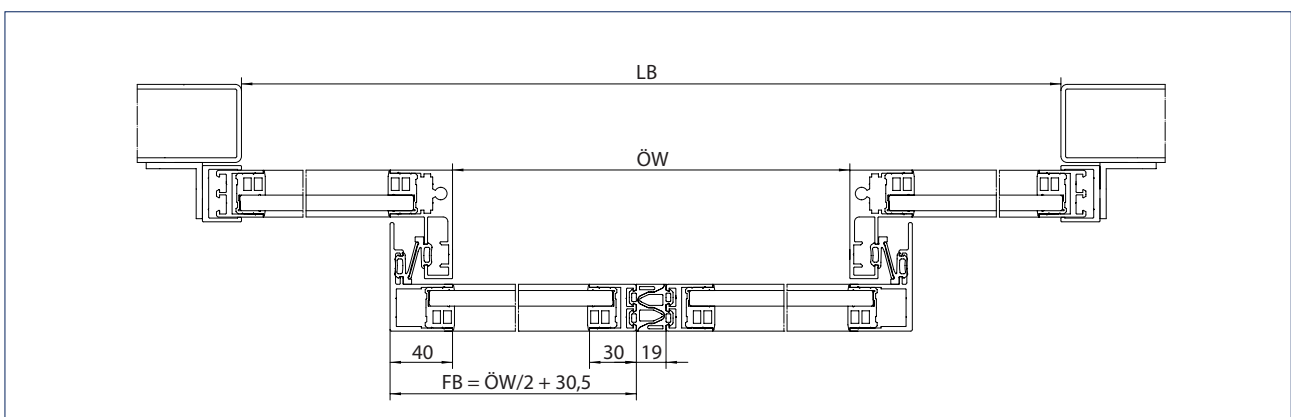

4-leaf door system

FB = Leaf width
 LB = Clear passage clearance
 ÖW = Opening width
 DH = Passage height

GEZE SLIMDRIVE SF

GEZE Slimdrive SF

Drive system for automatic folding doors

Wherever maximum passage widths must be achieved in tight spaces, the use of automatic doors with horizontal folding door leaves is the optimum solution. The GEZE automatic folding door system with the 7 cm drive height characteristic of the Slimdrive family guarantees maximum passage height for conversions, for example. The low overall height of the drive makes it almost unnoticeable, yet it is highly efficient. Retrofitting to existing façades is no problem. The optional break axle feature ensures the door is locked safely at night.



Technical data

Product features	SF	SF-FR
For 1-leaf door systems	-	-
For 2-leaf door systems	-	-
For 4-leaf door systems	●	●
Height	70 mm	
Depth	282 mm	
Leaf weight (max.) 4-leaf	40 kg	
Opening width 4-leaf	900 – 2000 mm	
Temperature range	-15 – 50 °C	
IP rating	IP20	
Disconnection from mains	Main switch in the drive	
Opening speed (max.)	0.8 m/s	
Closing speed (max.)	0.8 m/s	
Hold-open time	0 – 60 S	
Adjustable opening and closing force (max.)	150 N	
Automatic adaptation to traffic flow	●	●
Automatic reversal when an obstacle is detected	●	●
Pharmacy opening	●	●
Interlocking door system function	●	-
Vestibule function	●	-
Automatic opening in the event of a power failure	adjustable	fitted as standard
Automatic closing in the event of a power failure	adjustable	not available
Function in the event of a power failure	adjustable for 30 min. / 30 cycles	open
Automatic opening in the event of a fault	not available	fitted as standard

- = YES
- = NOT AVAILABLE

Drive components

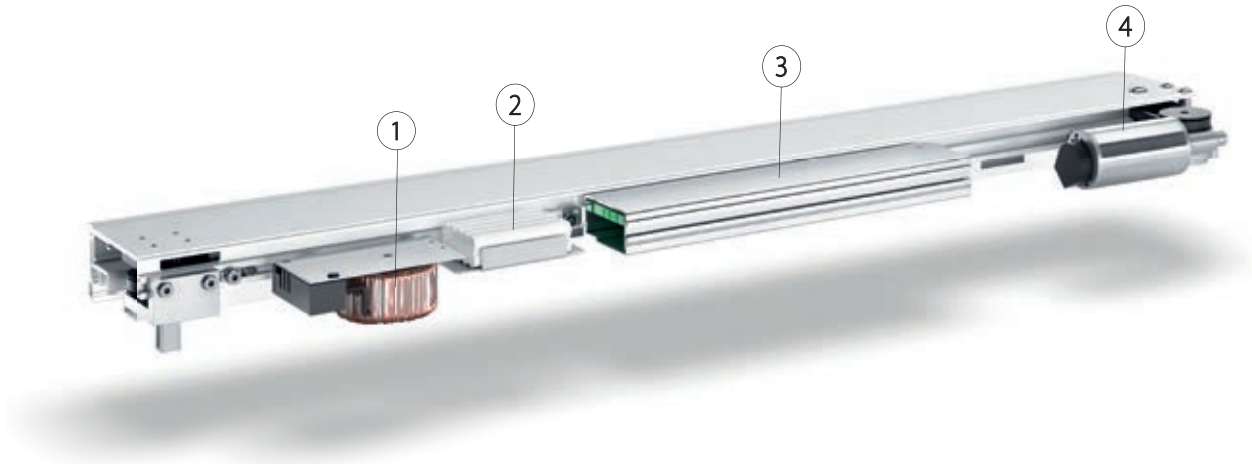

- 1 = Transformer
- 2 = Battery
- 3 = Control unit
- 4 = Motor

Technical data	SF	SF-FR
Transformer	Ring core with fuse and main switch	
Voltage	230 V	
Frequency	50 – 60 Hz	
Capacity rating	150 W	
Roller carriage		
Control unit	DCU1-NT	DCU1-2M-NT
With fault memory	•	•
With memory for statistical data	•	•
Software update possible	•	•
Optional bus interface	•	•
Connection for fire alarm system	•	•
Power supply for peripherals	•	•
Programmable inputs	3 pc.	
Programmable outputs	2 pc.	
Battery	NiCd, 24 V, 700 mAh	
Motor	Gear motor	Double gear motor
Torque	400 Ncm	

• = YES

GEZE SLIMDRIVE SF

Fitting versions

Fittings	SF
ISO glass fine-framed	•
MONO glass fine-framed	•
ESG clamping profile	-
All-glass system (GGS)	-
Integrated all-glass system (IGG)	-
Frame leaf (provided by customer)	-
Wooden leaf (provided by customer)	-

- = YES
- = NOT AVAILABLE



Kulturhotel Fürst Pückler, Bad Muskau, Germany (photo: Stefan Dauth)

Calculation of the drive length AL in mm*

Slimdrive SF		
	Opening width (ÖW)	Drive length (AL)
4-leaf	900 - 2000*	ÖW + 334

* Minimum overall length of the complete system with ISO glass profile system

Note:

Opening widths of emergency route sliding doors < 1000 mm are only permitted in exceptional cases.
 A continuous floor guide is generally recommended for outdoor systems.
 A continuous floor guide is recommended from 1400 mm for indoor use.
 The minimum opening widths depend on the requirements of building law.

Calculation of leaf and glass dimensions in mm

Slimdrive SF	
Driving leaf	Glass width = $\text{ÖW} / 4 + 10.5$
Following leaf	Glass width = $\text{ÖW} / 4 + 1.5$
Glass height	DH - 82
Glass thickness ISO glass	22
Glass thickness ESG/VSG	10

Note:

max. leaf ratio width to height 1:4

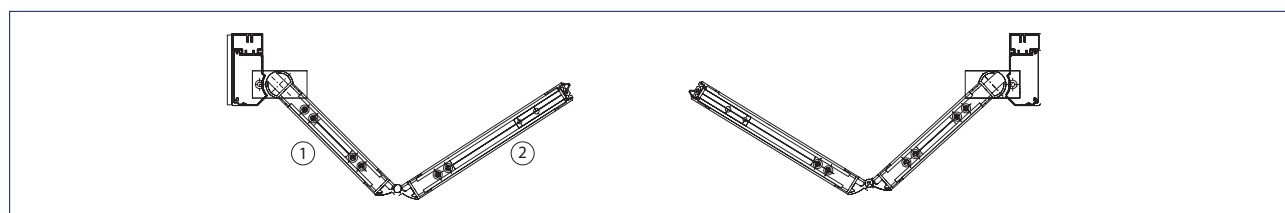

- 1 = Following leaf
- 2 = Driving leaf

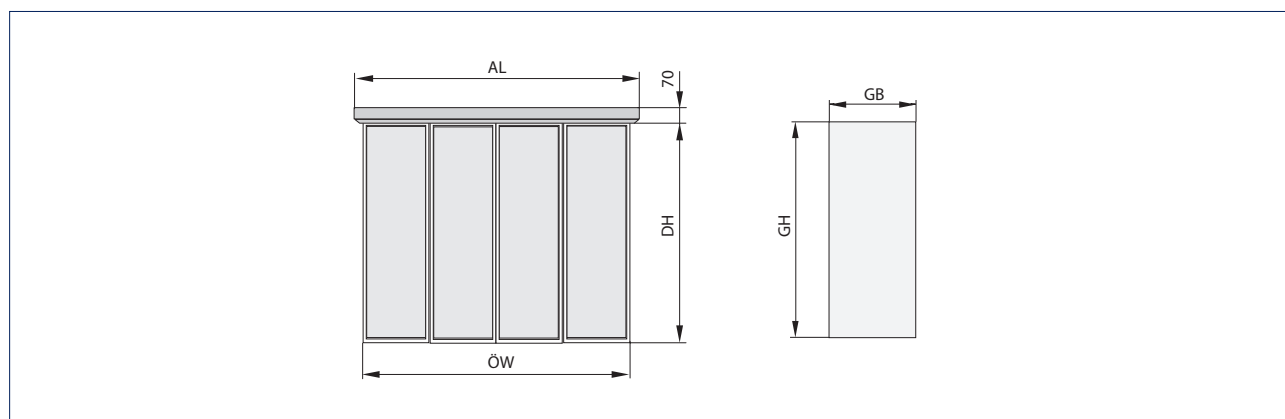

- AL = Drive length
- DH = Passage height
- GB = Glass width
- GH = Glass height
- ÖW = Opening width

GEZE SLIMDRIVE SF

With ISO/MONO glass fitting

Drawing no. 70497-ep01 + 70497-ep02

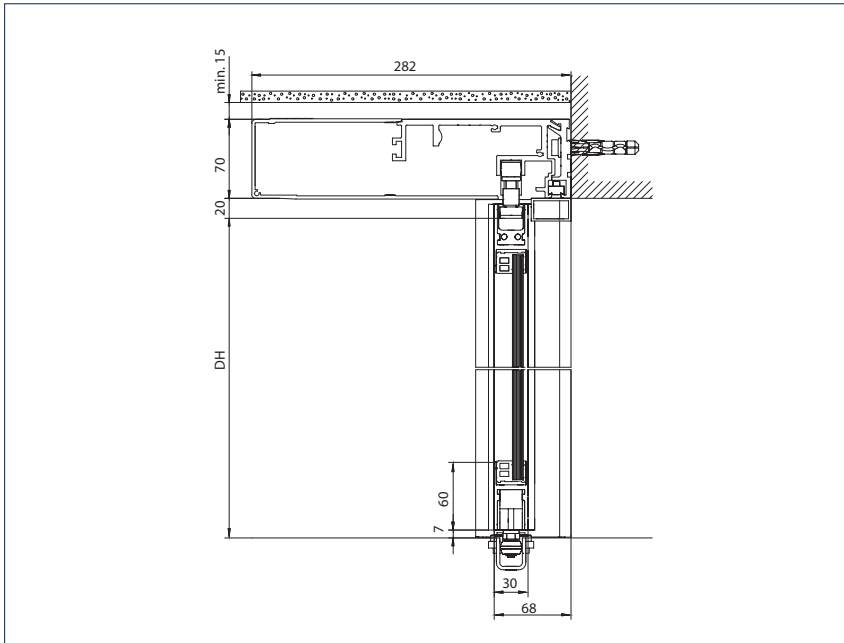

Door system with door leaf

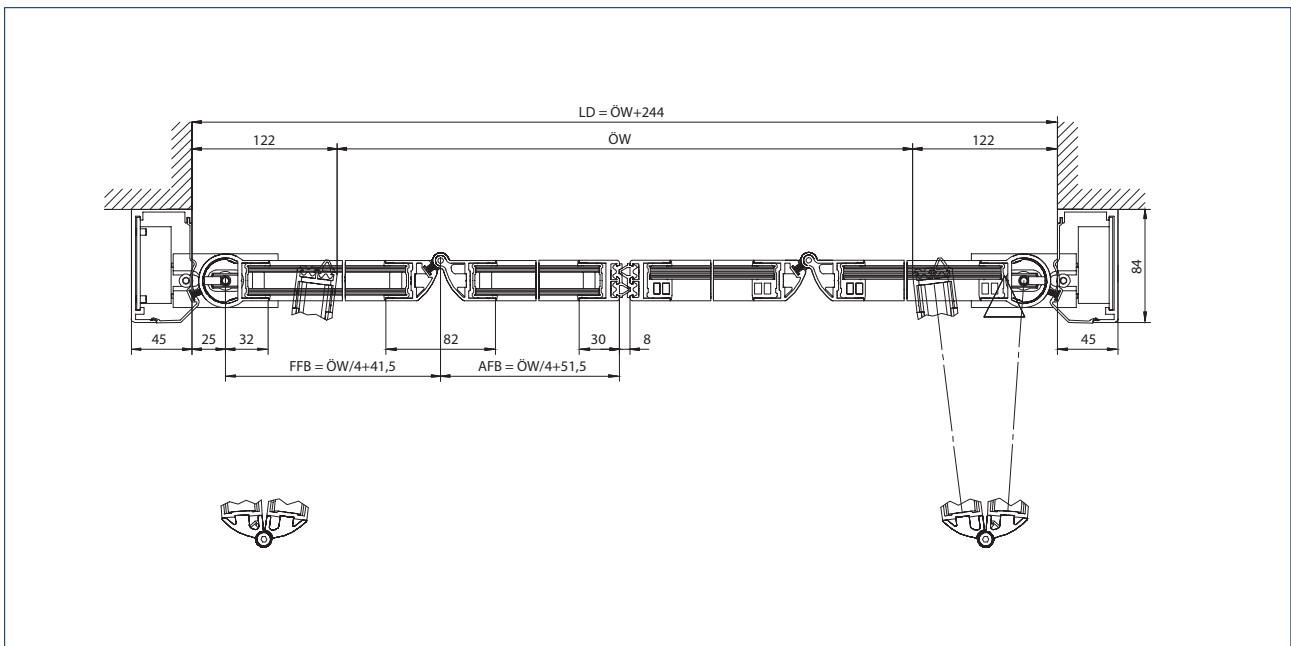

4-leaf door system

- LD = Clear passage
- ÖW = Opening width
- FFB = Width of following leaf
- AFB = Width of driving leaf
- DH = Passage height

GEZE Slimdrive SL-T30

Fire protection sliding doors with hold-open and trigger mechanism, permanent closing in the event of a fire

Fire protection doors are used to stop fire getting through wall openings in fire-retardant walls. Fire protection doors of resistance class T30 are fire-retardant doors in accordance with DIN 4102 and smoke-proof in accordance with DIN 18095. The closing function is guaranteed even in the event of a fire. After the fire alarm has been raised and/or the mains supply voltage has failed, the door automatically closes by means of stored energy. The necessary fire resistance class for a door depends on what the building is used for and the requirements made on the wall where the door is installed. The T30 sliding door systems are distributed in cooperation with partner companies.



Bistro-Kunsthalle, Ulm, Germany (photo: Nikolaus Grünwald)

GEZE SLIMDRIVE SLV

GEZE Slimdrive SLV

Freedom of design with corner sliding doors (SLV) – for angles between 90° and 270°

GEZE offers the perfect technical solution for the simple movement of corner sliding doors: The Slimdrive SLV drive – with an overall height of only 7 cm of course – is used wherever a special extravagant design is required or the entrance area has to follow certain architectural demands. If the Slimdrive SLV-FR is used, the corner sliding door can also be used on escape and rescue routes.



Trendpark, Neckarsulm, Germany (photo: Dirk Wilhelmy)

GEZE Slimdrive SL inclined

Fancy appearance and perfect integration in inclined glass façades

The GEZE drives for inclined sliding doors are ideal for narrow glass façades in post-rail structures. These sliding doors are used on 2-leaf doors and allow opening widths of up to 2500 mm. Inclined sliding doors are framed and offer a sleek appearance in fancy application. They can be used for inclined angles up to 9.9°. Larger angles are available on request.



Villa Soravia, Millstatt, Kärnten, Austria (photo: Helmut Kolaric)

SPECIAL FUNCTIONS FOR EMERGENCY EXIT ROUTES

Redundant sliding doors for escape and rescue routes with locked shop closing function (FR-LL)

Protected against forced opening from the outside through permanent locking with duplicate processing

This GEZE solution allows door systems on escape and rescue routes that are set in the mode of operation „Shop closing“ (one-way) to be locked via the intelligent control and the night-locking system. This increases the protection of the door against unauthorised opening from the outside. This type-tested FR-LL variant is ideal for use in areas where the shop closing mode of operation is to be used over a longer period. FR-LL sliding doors are used especially in banks, theatres and universities.

This version can be realised using the following drive series: Slimdrive, ECdrive and Powerdrive.



Sparkasse, Ulm, Germany (photo: Nikolaus Grünwald)

SPECIAL FUNCTIONS FOR EMERGENCY EXIT ROUTES

Redundant sliding doors for escape and rescue routes in both directions (FR-DUO)

For public buildings with several escape routes

This GEZE solution for special applications can be used in public buildings. Depending on how the rooms or building sections are used, escape routes in both directions are often required. The type-tested GEZE automatic sliding door can be used as an escape route door in both directions by using two monitored movement detectors on both sides. FR-DUO sliding doors are used especially in offices, airports and railways stations.

This version can be realised using the following drive series: Slimdrive, ECdrive and Powerdrive.



Cafe Luitpold, Munich, Germany (photo: Robert Sprang)

SPECIAL FUNCTIONS FOR EMERGENCY EXIT ROUTES

Redundant sliding doors for locked escape and rescue routes (FR-RWS)

Additional locking with monitored duplicate processing system and redundant emergency opening button

With the FR-RWS variant for automatic GEZE sliding doors, the door system can be adjusted by an intelligent control unit and monitored locking system in such a way that it is only possible to pass through the door on request. In the event of a power failure or other problems, the door reliably opens the escape route. FR-RWS sliding doors are used particularly in airports, railway stations, nursing and care homes.

This version can be realised using the following drive series: Slimdrive, ECdrive and Powerdrive.



Flughafen, Köln-Bonn, Germany (photo: Martin Jakob)

SPECIAL FUNCTIONS FOR EMERGENCY EXIT ROUTES

Sliding doors for escape and rescue routes according to CO48 (France)

Emergency opening using rubber cord

In the event of a power failure, the door can be opened once via the built-in elastic rope. CO48 sliding doors with escape route requirement are used in France and other regions where this solution is accepted.

This version can be realised using the following drive series: Slimdrive, ECdrive and Powerdrive.



Hippauf & Stegmüller, Arnstorf, Germany (photo: Robert Sprang) - exemplary picture

SOLUTIONS AND FUNCTIONS

Accessible toilet

Accessible toilets must be designed in such a way that people with all sorts of different handicaps can use the facilities without needing help. GEZE sliding door drives provide an indispensable service for this application, and guarantee a high level of convenience.

Function description

The door opens automatically after the large-scale button on the outside of the toilet has been pressed, and closes automatically after the set hold-open time has passed.

When the user presses the switchover inside the toilet cubicle, the „occupied“ sign outside the toilet is activated and the indicator light on the change-over switch comes on. At the same time, the elbow switch is deactivated on the outside and on the inside. This means the door cannot be opened by third parties nor by the user by mistake. When the user leaves the toilet, they press the switchover again. The „occupied“ sign outside and the telltale lamp inside both go off. The drive is activated by pressing the OPEN DOOR elbow switch inside the cubicle, and the door opens immediately.

In the event of a power failure, the door can always be opened using the emergency open button. Light curtains monitor the passage area on the inside and outside (two units) as well as the sliding door's travel path in the „open“ direction.



- 1 = Elbow switch (inside and outside)
- 2 = „Occupied“ indicator light
- 3 = Emergency-stop switch (recommended installation height: 1600 mm)
- 4 = Active infrared light curtain
- 5 = Emergency call pull switch
- 6 = Programme switch with key switch
- 7 = Sliding door leaf ISO/ESG (toughened safety glass) on site, fine-framed with satin finish foil, alternatively wooden leaf
- 8 = Side part

Vestibule systems

Vestibule systems are used to avoid draughts and reduce heat exchange. Preferably only one door should be opened.

Direction-detecting radar movement sensors only activate the door when people move towards it. This means the door closes more quickly after a person. A separate programme switch is compulsory for door systems in escape and rescue routes.

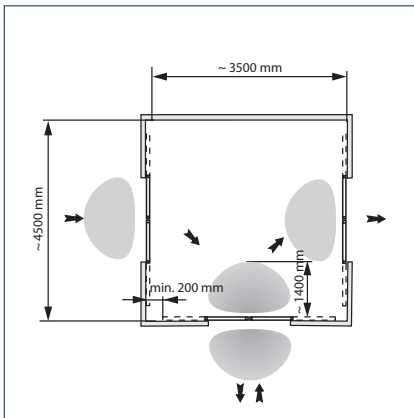

Combination example 1
 grey = Detection area

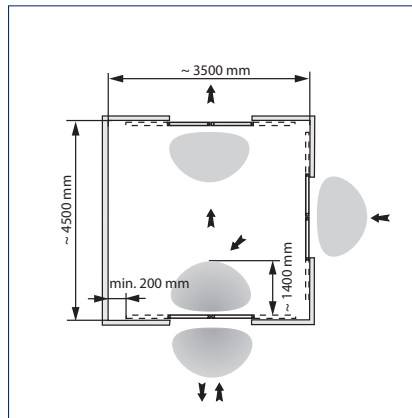

Combination example 2

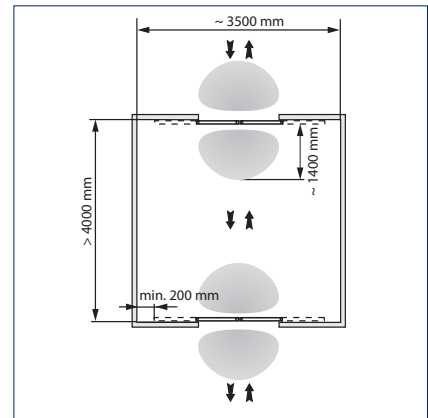

Combination example 3

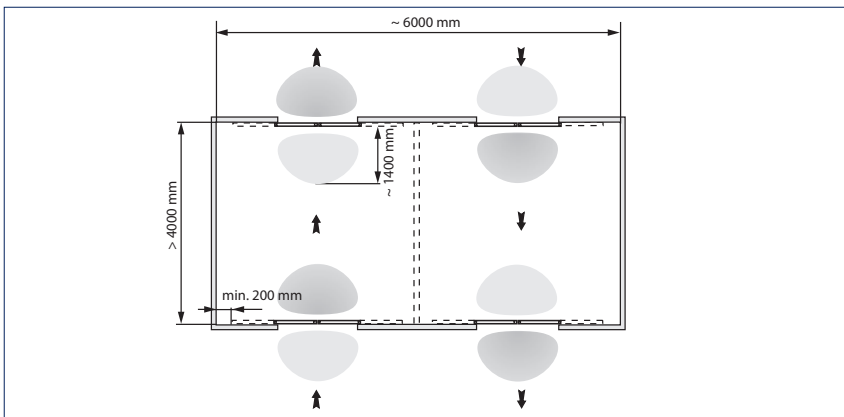

Combination example 4

SLIDING DOOR FITTINGS

Sliding door fittings

Complete design freedom thanks to innovative fitting systems

GEZE supplies the following fitting variations for all sliding door systems:

Door leaf with ISO glass fine-framed

Attractive door leaves with an extremely slim aluminium frame. They combine the advantages of the frame (e.g. seals) with an inconspicuous design.

Door leaf with MONO glass fine-framed

The same frame as with the ISO variation but with one single glass pane made of 10 mm ESG or VSG.

VSG = Verbund-Sicherheits-Glas (= laminated safety glass)

ESG = Einscheiben-Sicherheits-Glas (= toughened safety glass)

Door leaf with ESG clamping profile fine-framed

Profile system for 10 mm or 12 mm ESG. The glass pane is clamped in place near the top. Additional aluminium profiles at the sides and bottom ensure tightness, floor guide and compatibility with DIN 18650.

Frame leaf

The drive can be combined with door leaves made of a wide range of different frame profile systems, also thermally separated.

Wooden leaves

The drive can be combined with door leaves provided by the customer made of a wide range of materials e.g. wood.

Integrated all-glass system (IGG)

The profiles and the fittings system are integrated invisibly between the panes – without protruding or visible parts on the glass surface.

All-glass system (GGS)

All-glass design fittings for single point fixing offer maximum transparency. All the visible fittings are made of solid stainless steel.

Fitting variations

Fittings	ECdrive	SLNT	Powerdrive PL	Slimdrive SLT	Slimdrive SLRD	Slimdrive S-BO	Slimdrive SF
ISO glass fine-framed	•	•	•	•	•	•	•
MONO glass fine-framed	•	•	•	-	•	-	•
ESG clamping profile	•	-	•	-	-	-	-
All-glass system (GGS)	-	•	-	-	-	-	-
Integrated all-glass system (IGG)	-	•	-	•	-	-	-
Framed leaf (on site)	•	•	•	-	-	-	-
Wooden leaf (on site)	•	•	•	-	-	-	-
Hermetic leaf	-	-	•	-	-	-	-
Fire protection leaf T30 (Hörmann)	-	-	-	-	-	-	-

• = YES

- = NOT AVAILABLE

SLIDING DOOR FITTINGS



ISO glass fine-framed



MONO glass fine-framed



ESG clamping profile



Frame leaf (provided by customer)



Wooden leaves (provided by customer)



Integrated all-glass system (IGG)



All-glass system (GGS)



Hermetic leaf

ACCESSORIES

Operating automatic sliding doors

Programme switches for selection of the mode of operation for automatic sliding doors

GEZE offers programme switches for a wide range of individual needs. The switches are suitable for universal use – for surface-mounted or flush-mounted installation. The following switch types are available:

Display programme switch (DPS)

Key programme switch (TPS)

Mechanical programme switch (MPS)

The following modes of operation can be set:

“Permanently open”

The door moves to the OPEN position and remains open. Movement detector or opening button are deactivated.

“Night”

The movement detectors are switched inactive, the door closes.

Option: the door leaves are locked electrically to prevent forced opening.

“Shop closing” (one-way)

The door only opens and closes when someone goes out from the inside.

The movement detector outside is switched inactive, the one inside is switched active.

“Automatic”

The door opens as soon as it is activated via the movement detector or keys, and closes after a certain time which can be individually adjusted. Safety sensors protect the leaves' travel path. If there is someone in the door opening, the door will not close.

“Reduced opening width”

The settings determined in teach mode are activated or deactivated.

“OFF”

Drive and sensors are switched off, the door leaves can be moved manually.

Securing the programme switches

Automatic sliding doors in escape and rescue routes must be secured against operation by unauthorised people. The mechanical programme switch (MPS) is also available in a version that can be locked. The display programme switch (DPS) and key programme switch (TPS) can be combined with a key switch. Alternatively, these programme switches can be secured using a code.



Display programme switch (DPS)



Key programme switch (TPS)



Mechanical programme switch (MPS)

Automatic activation

Reliable activation with GEZE sensors

Combined detectors

Combined detectors are radar movement detectors using an infrared light curtain. Activation and protection are integrated in the sensor, reducing installation efforts. Individual attachment possibilities through wall, ceiling or integrated ceiling recess installation provide lots of design freedom. The use of a remote control guarantees quick and easy commissioning. The sensor is reliably activated on the basis of direction detection and cross-traffic fade-out. Slow movements can be detected thanks to the "slow motion detection" feature. The protection area can be configured as required. Combined detectors for escape and rescue routes offer maximum safety through integrated self-monitoring.



Combined detector GC 363



Combined detector GC 365

Radar movement detectors

Radar movement detectors register all objects that move within the radar field. All movements within the radiation range cause a time-delayed reflection which is forwarded as a door opening signal. The pre-programmed convenience setting of the GEZE radar movement detectors ensures they can be put into operation quickly. Automatic configuration is possible via keys or a remote control. Reliable detection is achieved with a clearly defined radar field. Energy can be saved through detection of people's direction of movement. Excessive door opening is avoided since cross-traffic can be faded out.



Radar movement detector GC 304

ACCESSORIES

Manual activation

Push buttons

GEZE push buttons for the wireless activation of system doors – reliable, convenient and safe at the push of a button.

Non-contact LED sensor button

The design-oriented and sturdy LED sensor button makes intuitive and straightforward operation possible. No great efforts are required for activation – touching the button slightly is sufficient. Suitable for use both indoors and outdoors, the LED sensor button can be recognised easily in the dark thanks to the blue LED lighting. In addition, the sensor has raised Braille lettering on it. An acoustic and visual signal shows activation through the button. The button is waterproof, impact-resistant and vandalism-proof. This makes it very well suited for outdoor use or installation in the floor.

Non-contact proximity switch

Open doors in a flash: With the GC 306, internal doors without precise perception requirement can be activated cleanly and comfortably. Active infrared sensors ensure hygienic access to toilet facilities, for example. The risks of infection are also minimised in hotel kitchens, hospitals and doctors' surgeries. The impulse generator is installed at hand height and precisely detects people and objects – independently of their direction of movement – both in the direct vicinity of only 5 cm as well as 0.5 m away. The different scanning ranges can be optimally adapted to existing environmental conditions and the wishes of the user groups. The non-contact sensor system provides maximum operating convenience – people only need to approach them to trigger the automatic opening mechanism – and is absolutely hygienic. The optimum system structure permits simple and time-saving installation in the flush-mounted box.

Radio activation

GEZE radio transmitters are used for wireless activation of doors and windows as a multi-channel solution. For every additional channel, an additional electrical device or function can be switched at the push of a button. Thanks to the very small size of the radio modules, radio transmitters can easily be integrated in the drive or in a flush-mounted box. They can also be clipped directly into the elbow switched and mounted without wires on glass.



Push buttons



LED sensor switch



Non-contact proximity switch GC 306



Radio activation



Elbow plastic switch



Stainless steel elbow switch IP65

Electronic protection

Infrared light curtain

GEZE light curtains are used to secure posts, main and secondary closing edges both inside and outside. The light curtains have an invisible and non-contact protective device. Precise detection is possible through a clearly defined field, the size of which can be adjusted. Individual applications allow the use of light curtains as protective sensors or opening impulse generators.

Infrared photoelectric barrier

GEZE safety photoelectric barriers are available as single-beam and double-beam versions. This guarantees the easy and reliable protection of main closing edges with tried-and-trusted technology. The design permits flexible installation in different door profiles. The integrated electronics guarantee fast installation and compact space requirements.

Note: In Europe (CEN Countries), as of 2013, the use of photoelectric barriers is not permitted according to EN 16005 / DIN 18650.



Infrared light barrier

Mechanical protection

Protective leaf

Protective leaves are used on escape and rescue routes if it is not possible to secure the secondary closing edges using light curtains. Automatic sliding doors on escape and rescue routes must be able to be opened at any time.

Safety leaf

Safety leaves are used to secure the cavities behind automatic sliding doors in post-rail structures.



Protective leaf



Safety leaf

ACCESSORIES

Locks

GEZE Lock M hook bolt lock

The new GEZE Lock M is a manual hook bolt lock for the Slimdrive SL NT and ECdrive sliding door systems. This high-quality locking mechanism is invisibly built into the vertical profile of the door leaves, allowing the door to be locked and unlocked quickly and reliably. The door can be locked and unlocked from the inside or outside using a key in the lock which is installed at a convenient height. The lock possesses a profile cylinder with 3, 6 or 9 keys with the construction length 32 mm (16/16). If standard construction lengths such as 60 mm (30/30 double cylinder) or 40 mm (30/10 half cylinder) are used, danger areas emerge on the basis of the surviving cylinder, which necessitate a restriction of the opening width. The profile cylinder can survive without restrictions if no protective leaves are available on the inside. As an option, GEZE can provide a pushing rosette for standard lock cylinders for installation on the drive side / inside. The extremely sturdy GEZE Lock M provides excellent protection against vandalism and unauthorised access.



GEZE Lock M hook bolt lock



GEZE Lock M hook bolt lock installed

GEZE Lock A hook bolt lock

The new GEZE Lock A is an automatic hook bolt lock for the Slimdrive SL NT and ECdrive sliding door systems. This high-quality single or two-point locking mechanism allows the door to be locked and unlocked quickly and reliably. The locking motor is invisibly integrated into the vertical profile of the door leaves. The sliding door control unit makes parameter setting and control easy. The manual emergency unlocking facility allows the door to be opened from the inside at any time in the event of a power failure.



GEZE Lock A hook bolt lock



GEZE Lock A hook bolt lock installed

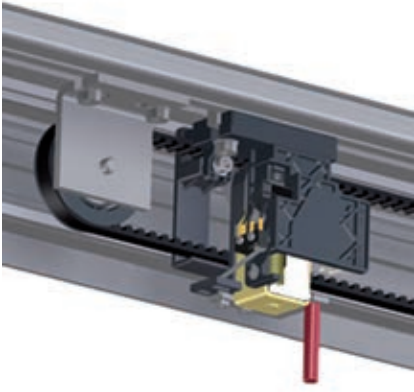

Toothed belt locking

Toothed belt locking

This electro-magnetic bi-stable locking system ensures more safety, because it stays locked even without electric current. Manual emergency unlocking is possible at any time. Typical for this type of locking is permanent monitoring by the control unit. Up to two contacts for external applications (e.g. alarm systems) can be integrated as an option. Thanks to the free choice of positioning in the drive, the toothed belt locking is not only easy to install, it also makes special locking functions possible, e.g. locked pharmacy opening of the sliding doors.



Floor lock

Floor lock

The GEZE floor lock is used for the easy locking of door leaves with the fine-framed ISO profile system at floor level. Customary profile cylinders can be used for the floor locks. This means the solution is suitable for optimum integration in closing systems. Operation is manual, with the key, either only from the inside or from the inside and outside.



Rod locking

Rod locking

Rod locking increases safety and protection against burglary. The multi-point locking – both upwards and in the ground – provides solid resistance against attempts to be levered open. The locking rod is integrated invisibly in the fine-framed ISO profile system. The system can be unlocked both electrically and mechanically. Rod locking can be used in the Slimdrive SL and Slimdrive SLT drives. Escape and rescue routes can also be protected by rod locking.

ACCESSORIES

Service Tools

GEZEconnects

Bluetooth is an internationally standardised short-distance radio signal with a range of up to ten metres. The software GEZEconnects makes wire-less connection via Bluetooth possible between a computer and the GEZE automatic door systems. All door system settings can be carried out via an intuitive graphic interface, stored, sent by e-mail and transferred to a word processing programme as a protocol. Diagnosis functions show the most important function parameters of the door system in real time, so that problems are recognised at a glance and can be eliminated. All the pre-settings can be taken over very easily for further door systems. The convenient documentation of initial operation, servicing and diagnosis protocols as well as all statistical data can be downloaded at any time. Password protection to freeze operating parameters and servicing data guarantees there will be no unauthorised modifications made.

Service terminal ST 220

Mobile, handy and straightforward – that is parameter setting for the automatic GEZE door systems using the service terminal ST 220. Communication and data exchange between the service terminal and the door drive is via an integrated RS485 interface. The large illuminated interface is easy to operate thanks to the plain text display. The service terminal is equipped with a readout function for servicing and diagnosis work. Power is supplied via the door system. Password protection to freeze operating parameters and servicing data guarantees there will be no unauthorised modifications made.

Note: Parameters of GEZE drives may only be changed by technicians trained in accordance with DIN 18650/EN 16005 and authorized by the manufacturer (GEZE).



GEZEconnects



Service terminal ST 220

Cable diagram control units for sliding doors

For more detailed information about connection of the activation elements and sensors see the connection diagram 160924 (English version).

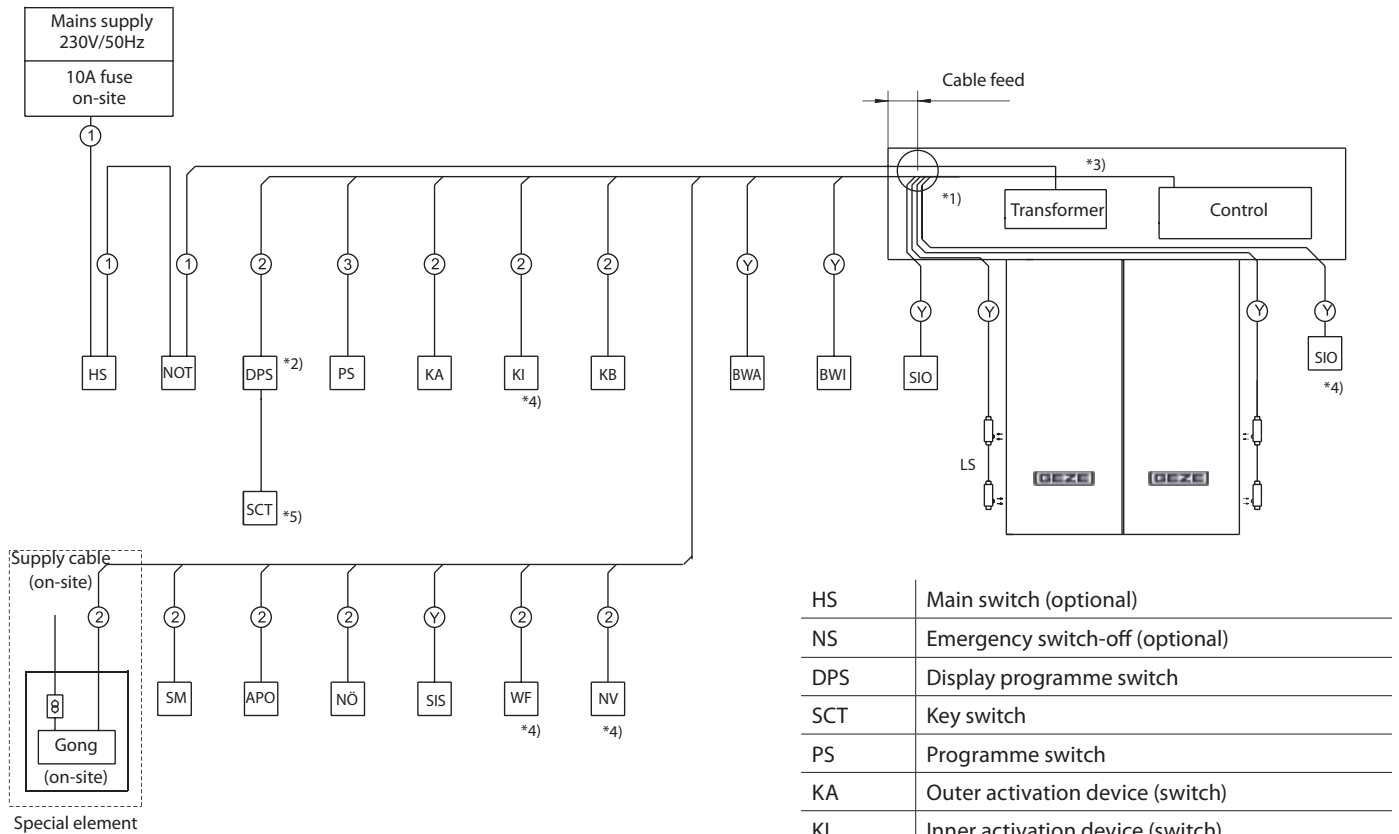

Wire cross-section:

- ① NYM-J 3 x 1.5 mm²
- ② I-Y(ST)Y 2 x 2 x 0.6 mm
- ③ I-Y(ST)Y 3 x 2 x 0.6 mm
- Ⓨ Scope of supply GEZE

Safety

- Cable routing according to VDE 0100
- Cable routing, connection and initial operation may only be carried out by authorised specialists.
- GEZE does not accept any warranty and service performances in combination with external brands.

Notes

- 1) Cable feed through the side plate or through the track on the left. To protect the cables, avoid sharp edges or use edge protection.
- 2) Cable length max. 100 m
- 3) Allow signal cables to protrude at least 5 m and mains cables at least 2 m out of the wall
- 4) Contact switch (KI) not allowed for escape and rescue routes
- 5) Optionally connectable to escape and rescue route door control units
Alternative without key switch: set access code of DPS via ST 220 or GEZEconnects
- 6) According to DIN 18650 / EN 16005, photoelectric barriers must not be used as sole protection device in the closing area

References



Slimdrive SL NT, Hotel Schloss Elmau Retreat, Elmau, Germany (photo: Robert Sprang)



Slimdrive SL-FR with side parts, Olgahospital / women's clinic, Stuttgart, Germany (photo: Jürgen Pollak)

GEZE SLIDING DOOR SYSTEMS



Slimdrive SL NT with vestibule, Augustinum, Stuttgart, Germany (photo: Dirk Wilhelmy)



ECdrive, Augustinum, Stuttgart, Germany (photo: Dirk Wilhelmy)

POTENTIAL APPLICATIONS OF GEZE PRODUCTS

You will find more product information in the relevant brochures, see ID numbers.

Door technology	
01	Overhead door closers ID 091593, ID 091594
02	Hold-open systems ID 091593, ID 091594
03	Integrated door closers ID 091609
04	Floor springs and all-glass systems ID 091607
05	Sliding door fitting systems and linear guides ID 123605, ID 000586
Automatic door systems	
06	Swing doors ID 144785
07	Sliding, telescopic and folding doors ID 143639
08	Curved sliding doors ID 135772
09	Revolving doors ID 132050
10	Activation devices and sensors ID 142655
Smoke and heat extraction and window technology	
11	Fanlight opening systems ID 127787
12	Electric opening and locking systems ID 154851
13	Electrical spindle and linear drives ID 154851
14	Electric chain drives ID 154851
15	Smoke and heat extraction systems ID 154851
Safety technology	
16	Emergency exit systems ID 132408
17	Access control systems ID 132158
18	Panic locks ID 132848
19	Electric strikes ID 148666
20	Building management system ID 132408
Glass systems	
21	Manual sliding wall systems (MSW) ID 104377
22	Integrated all-glass systems (IGG) ID 104366



POTENTIAL APPLICATIONS OF GEZE PRODUCTS



Door technology

The functionality, superior performance and reliability of GEZE door closers are impressive. A common design across the range, the ability to use them on all common door leaf widths and weights, and the fact that they can be individually adjusted makes their selection simple. They are continually being improved and enhanced with up-to-date features. For example, the requirements of fire protection and accessibility are fulfilled with a door closer system.

Automatic door systems

GEZE automatic door systems open up a huge variety of options in door design. The latest, innovative high-performance drive technology, safety, ease of accessibility and first class universal drive design set them apart. GEZE offers complete solutions for individual requirements. A dedicated division is responsible for the development and construction of individual special designs.

Smoke and heat extraction and window technology

GEZE smoke and heat extraction systems and ventilation technology provide complete systems solutions combining the many requirements of different types of windows. We supply a full range from energy efficient drive systems to natural ventilation and complete solutions for supplying and extracting air, also as certified SHEVs.

Safety technology

GEZE safety technology sets the standards where preventative fire protection, access control and anti-theft security in emergency exits are concerned. For each of these objectives GEZE offers tailored solutions, which combine the individual safety requirements in one intelligent system and close doors and windows in case of danger in a coordinated manner.

Building systems

In GEZE's Building Management System GEZE door, window and safety products can be integrated in to the security and control systems of the building. A central control and visualisation system monitors various automation components in the building and offers security through many different networking capabilities.

Glass systems

GEZE glass systems stand for open and transparent interior design. They can either blend discreetly into the architecture of the building or stand out as an accentuated feature. GEZE offers a wide variety of technologies for functional, reliable and aesthetic sliding wall or sliding door systems providing security with lots of design scope.

GEZE GmbH
P.O. Box 1363
71226 Leonberg
Germany

GEZE GmbH
Reinhold-Vöster-Straße 21-29
71229 Leonberg
Germany
Telefon +49 7152 203 0
Telefax +49 7152 203 310
www.geze.com

Germany
GEZE GmbH
Niederlassung Süd-West
Breitwiesenstraße 8
71229 Leonberg
Tel. +49 7152 203 594
Fax +49 7152 203 438
leonberg.de@geze.com

GEZE GmbH
Niederlassung Süd-Ost
Parkring 17
85748 Garching bei München
Tel. +49 7152 203 6440
Fax +49 7152 203 77050
muenchen.de@geze.com

GEZE GmbH
Niederlassung Ost
Albert-Einstein-Ring 5
14532 Kleinmachnow bei Berlin
Tel. +49 7152 203 6840
Fax +49 7152 203 76849
berlin.de@geze.com

GEZE GmbH
Niederlassung Mitte/Luxemburg
Adenauerallee 2
61440 Oberursel (b. Frankfurt)
Tel. +49 7152 203 6888
Fax +49 7152 203 6891
frankfurt.de@geze.com

GEZE GmbH
Niederlassung West
Heltorfer Straße 12
40472 Düsseldorf
Tel. +49 7152 203 6770
Fax +49 7152 203 76770
duesseldorf.de@geze.com

GEZE GmbH
Niederlassung Nord
Albert-Schweitzer-Ring 24-26 (3. OG)
22045 Hamburg
Tel. +49 7152 203 6602
Fax +49 7152 203 76608
hamburg.de@geze.com

GEZE Service GmbH
Niederlassung Süd-West
Reinhold-Vöster-Straße 25
71229 Leonberg
Tel. +49 7152 203 392
Fax +49 7152 203 359
service-leonberg.de@geze.com

GEZE Service GmbH
Niederlassung Süd
Parkring 17
85748 Garching bei München
Tel. +49 7152 203 392
Fax +49 7152 9233 859
service-muenchen.de@geze.com

GEZE Service GmbH
Niederlassung Mitte
Oberurseler Str. 69
61440 Oberursel
Tel. +49 7152 9233 92
Fax +49 7152 9233 659
service-oberursel.de@geze.com

GEZE Service GmbH
Niederlassung West
Heltorfer Straße 12
40472 Düsseldorf
Tel. +49 7152 9233 92
Fax +49 7152 9233 559
service-duesseldorf.de@geze.com

GEZE Service GmbH
Niederlassung Ost
Albert-Einstein-Ring 5
14532 Kleinmachnow bei Berlin
Tel. +49 7152 9233 92
Fax +49 7152 9233 759
service-berlin.de@geze.com

GEZE Service GmbH
Niederlassung Nord
Albert-Schweitzer-Ring 24-26 (3. OG)
22045 Hamburg
Tel. +49 7152 9233 92
Fax +49 7152 9233 459
service-hamburg.de@geze.com

Austria
GEZE Austria
Wiener Bundesstrasse 85
A-5300 Hallwang
Tel: +43 6225 87180
Fax: +43 6225 87180 299
austria.at@geze.com

**Baltic States –
Lithuania / Latvia / Estonia**
Tel. +371 678960 35
baltic-states@geze.com

Benelux
GEZE Benelux B.V.
Industrieterrein Kapelbeemd
Steenoven 36
5626 DK Eindhoven
Tel. +31 4026290 80
Fax +31 4026290 85
benelux.nl@geze.com

Bulgaria
GEZE Bulgaria - Trade
Representative Office
Nickolay Haitov 34 str., fl. 1
1172 Sofia
Tel. +359 247043 73
Fax +359 247062 62
office-bulgaria@geze.com

China
GEZE Industries (Tianjin) Co., Ltd.
Shuangchenzhong Road
Beichen Economic Development
Area (BEDA)
Tianjin 300400, P.R. China
Tel. +86 22 26973995
Fax +86 22 26972702
chinasales@geze.com.cn

GEZE Industries (Tianjin) Co., Ltd.
Branch Office Shanghai
Jia Little Exhibition Center
Room C 2-102
Shenzhuan Rd. 6000
201619 Shanghai, P.R. China
Tel. +86 21 52340960
Fax +86 21 64472007
chinasales@geze.com.cn

GEZE Industries (Tianjin) Co., Ltd.
Branch Office Guangzhou
Room 17 C 3
Everbright Bank Building, No.689
Tian He Bei Road
510630 Guangzhou, P.R. China
Tel. +86 20 38731842
Fax +86 20 38731834
chinasales@geze.com.cn

GEZE Industries (Tianjin) Co., Ltd
Branch Office Beijing
Room 04-05, 7th Floor
Red Sandalwood Plaza
No. 27 Jianguo Road
Chaoyang District
100024 Beijing, P.R.China
Tel. +86 10 85756009
Fax +86 10 85758079
chinasales@geze.com.cn

France
GEZE France S.A.R.L.
ZAC de l'Orme Rond
RN 19
77170 Servon
Tel. +33 1 606260 70
Fax +33 1 606260 71
france.fr@geze.com

Hungary
GEZE Hungary Kft.
Hungary-2051 Biatorbágy
Vendel Park
Huber u. 1.
Tel. +36 23532 735
Fax +36 23532 738
office-hungary@geze.com

Iberia
GEZE Iberia S.R.L.
C/ Andorra 24
08830 Sant Boi de Llobregat
(Barcelona)
Tel. +34 902194 036
Fax +34 902194 035
info@geze.es

India
GEZE India Private Ltd.
MF 2 & 3, Guindy Industrial Estate
Ekkattuthangal
Chennai 600 097
Tamilnadu
Tel. +91 44 406169 00
Fax +91 44 406169 01
office-india@geze.com

Italy
GEZE Italia S.r.l
Sede di Vimercate
Via Fiorbellina 20
20871 Vimercate (MB)
Tel. +39 0399530401
Fax+39 039 9530459/419
italia.it@geze.com

Sede di Roma
Via Lucrezia Romana, 91
00178 Roma
Tel. +39 06 726531 1
Fax +39 06 726531 36
roma@geze.biz

Poland
GEZE Polska Sp.z o.o.
ul. Marywilska 24
03-228 Warszawa
Tel. +48 224 404 440
Fax +48 224 404 400
geze.pl@geze.com

Romania
GEZE Romania S.R.L.
IRIDE Business Park,
Str. Dimitrie Pompeiu nr. 9-9a,
Building 10, Level 2, Sector 2,
020335 Bucharest
Tel.: +40 212507 750
Fax: +40 316201 258
office-romania@geze.com

Russia
OOO GEZE RUS
Gamsonovskiy Per. 2
115191 Moscow
Tel. +7 495 93306 59
Fax +7 495 93306 74
office-russia@geze.com

Scandinavia – Sweden
GEZE Scandinavia AB
Mallslingan 10
Box 7060
18711 Täby, Sweden
Tel. +46 87323 400
Fax +46 87323 499
sverige.se@geze.com

Scandinavia – Norway
GEZE Scandinavia AB avd. Norge
Industriveien 34 B
2073 Dal
Tel. +47 63957 200
Fax +47 63957 173
norge.se@geze.com

Scandinavia – Denmark
GEZE Danmark
Branch office of GEZE Scandinavia AB
Mårkærvej 13 J-K
2630 Taastrup
Tel. +45 463233 24
Fax +45 463233 26
danmark.se@geze.com

Singapore
GEZE (Asia Pacific) Pte. Ltd.
21 Bukit Batok Crescent
#23-75 Wcega Tower
Singapore 658065
Tel: +65 6846 1338
Fax: +65 6846 9353
gezesea@geze.com.sg

South Africa
Geze South Africa (Pty) Ltd.
GEZE, Building 3, 1019 Morkels Close
Midrand 1685
Tel: + 87 94337 88
Fax: + 86 66137 52
info@gezesa.co.za

Switzerland
GEZE Schweiz AG
Zelglimatte 1A
6260 Reiden
Tel. +41 62 28554 00
Fax +41 62 28554 01
schweiz.ch@geze.com

Turkey
GEZE Kapı ve Pencere Sistemleri
San. ve Tic. Ltd. Sti.
İstanbul Anadolu Yakası Organize
Sanayi Bölgesi
Gazi Bulvarı Caddesi 8.Sokak No:8
Tuzla-İstanbul
Tel. + 90 216 45543 15
Fax + 90 216 45582 15
office-turkey@geze.com

Ukraine
LLC GEZE Ukraine
ul. Viskoznaya, 17,
Building 93-B, Office 12
02660 Kiev
Tel./Fax +38 445012225
office-ukraine@geze.com

United Arab Emirates/GCC
GEZE Middle East
P.O. Box 17903
Jebel Ali Free Zone
Dubai
Tel. +971 48833 112
Fax +971 48833 240
gezeme@geze.com

United Kingdom
GEZE UK Ltd.
Blenheim Way
Fradley Park
Lichfield
Staffordshire WS13 8SY
Tel. +44 15434430 00
Fax +44 15434430 01
info.uk@geze.com

GEZE REPRÄSENTANT