



GEZE SWING DOOR SYSTEMS
CLEVER SYSTEMS. FOR BARRIER-FREE ACCESS.



TABLE OF CONTENTS

Foreword: GEZE swing door systems	4
Overview table	5
Types of installation	6
Automatic swing door systems	
For fire and smoke protection doors (F)	7
With integrated closing sequence control (IS)	7
With integrated closing sequence control for double-leaf fire and smoke protection doors (F-IS)	8
With integrated closing sequence control for double-leaf doors, automatic doors and door closer function (IS/TS)	8
For fresh air supply as well as doors in emergency exits (Invers)	9
For large and heavy doors, as well as frequently used doors (EN7)	9
Special area of application: Accessible toilet	10
Swing door drives	
GEZE Ecturn	11
GEZE Ecturn Inside	23
GEZE Slimdrive EMD	28
GEZE TSA 160 NT	42
GEZE Powerturn	54
Accessories (Cover, mounting plate, link arm, roller guide rail with lever)	
Operation	70
Activation	71
Protection	73
Service Tools	79
References	80

GEZE swing door systems

Open and close doors easily

The automatic swing door systems from GEZE make passing through a door easier every time when manual opening is too hard or inconvenient. They are recommended in public as well as in private buildings, when convenience, accessibility, safety and hygiene are necessary or when energy has to be saved: in shopping centres, schools, office or industrial buildings, airports, hospitals, vestibules or in individual homes.

Ecturn

The electromechanical swing door drive Ecturn is recommended for single-leaf smaller internal and entrance doors of up to 125 kilogram with moderate access frequency. The Ecturn is so small and discreet that even frameless all-glass doors can be automated. In addition, the Ecturn Inside enables an "invisible" door automation. Thanks to its small dimensions, it can be integrated in the door leaf or in the frame. The Ecturn Inside was labelled with the Interior Innovation Award by the German Design Council.

Slimdrive EMD

The electromechanical swing door drive Slimdrive EMD is suitable for single and double-leaf doors of up to 230 kilogram, slim profiles and small spaces. The Slimdrive EMD, with a drive height of only seven centimetres, various cover designs and adjustment options, fits in every door situation and is also approved in fire protection doors. It was already labelled with two Plus X Awards.

TSA 160 NT

The approved electrohydraulic swing door drive TSA 160 NT opens and closes doors of up to 310 kilogram safely and reliably. It manages high public access easily. Multiple variations enable various applications.

Powerturn

The electromechanical swing door drive Powerturn provides a high function and design variety. The robust, efficient drive opens single and double-leaf large and heavy doors with leaf weights of up to 600 kilogram quietly and reliably. With its 7-cm-optics, it fits in every door design. Thanks to the Smart swing function, even manual door-opening is child's play. Hence the Powerturn is a prime example for Universal Design.

Design possibilities for swing door systems



- 1 = Drive
- 2 = Radar movement detector
- 3 = Plastic elbow switch
- 4 = Programme switch
- 5 = Proximity switch
- 6 = Elbow switch
- 7 = Glass LED sensor button
- 8 = Interruption button
- 9 = Foot contact switch
- 10 = Sensor strip

DIN 18650

The industrial standard DIN 18650 was created to be able to guarantee operators and users of automatic doors optimum safety. GEZE swing door systems with automatic function have been type-tested to DIN 18650 and certified.

EN 16005

The new European standard EN 16005 sets out the design requirements and testing methods used to ensure the safe use of automatic doors. The new standard has created a Europe-wide safety standard for automatic doors.

All automatic door systems and safety sensors from GEZE meet the EN 16005 standard and are available.

DIN 18040

DIN 18040 formulates the safety objectives for publicly accessible buildings and apartments and shows the requirements of people with sensory and cognitive limitations. The automatic swing door systems of GEZE are attractive not only for people with limited mobility. Accessibility is also reflected in the concept of Universal Design and in the topical subject "Inclusion". According to this concept, buildings must be made easy to access for the largest possible group of people, and it must be possible to use them without help.

Ecturn, EMD, TSA 160 NT AND POWERTURN

Overview table for swing door systems

		Ecturn	Slimdrive EMD	TSA 160 NT	Powerturn
Product features					
Dimensions drive (height x width x depth)		60x580x60 mm	70x650x121 mm	100x690x121 mm	70x720x130 mm
Leaf weight (max.)		125 kg	180 kg 230 kg*	250 kg 310 kg**	600 kg
Leaf width (min.)	GLS / RS ¹	650 mm	850 mm	690 mm	800 mm
	GST		750 mm		
Leaf width (max.)	GLS / RS ¹	1100 mm	1400 mm	1400 mm 1600 mm**	1600 mm
	GST				
Hinge clearance on double-leaf doors	GLS / RS ¹	–	1700-2500 mm	1470-3200 mm**	1600 – 3200 mm
	GST	–	1500-2800 mm		
Opening and closing speed adjustable		•	•	•	•
Electrical closing sequence control			•	•	•
Electromechanical drive		•	•		•
Electrohydraulic drive				•	
External doors / Internal doors		– / •	• / •	• / •	• / •
Integrated in door leaf or in door frame		•***			
1-leaf / 2-leaf		• / –	• / •	• / •	• / •
Guide rail / Roller guide rail / Link arm		• / – / •	– / • / •	– / • / •	– / • / •
Functions					
Automatic		•	•	•	•
Push & Go adjustable		•	•	•	•
Low-Energy		•	•		•
Smart swing					•
Servo			•		
Variants					
For fire and smoke protection doors (F)			•* / ****	•	•
With integrated smoke switch (F/R)			•* / ****		•
With integrated closing sequence control (IS)			•*	•	•
With integrated closing sequence control for double-leaf fire and smoke protection doors (F-IS)			•* / ****	•	•
With integrated closing sequence control for double-leaf doors, automatic doors and door closer function (IS/TS)				•	•
For fresh air supply as well as doors in emergency exits (Invers)			•	•	
For large and heavy doors, as well as frequently used doors (EN7)				•**	•
Page		11	28	42	54

RS = Roller guide rail

GLS = Guide rail

GST = Link arm

• = Yes 1 = GLS: Ecturn / RS: Slimdrive, TSA and Powerturn * = Slimdrive EMD-F ** = TSA 160 NT EN7 *** = Ecturn Inside

**** = Types of installation: transom installation hinge side with roller guide rail / transom installation opposite hinge side with link arm

Note: The maximum possible leaf weight in relation to leaf width can be found in the chapter on areas of application (diagrams)!

Types of installation for swing door systems

The following diagrams show the installation possibilities for swing doors and the drives which can be used to realise this application.

Notes

A door stopper is always required.

We recommend link arms for external doors. Wind loads and underpressure or excess pressure must also be taken into account.

Installation on the hinge side

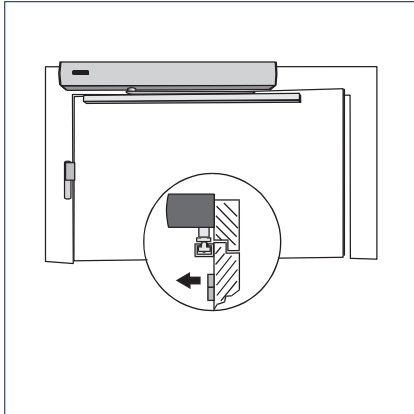

Transom installation with guide rail / roller guide rail

- 1 = ECturn
- 2 = Slimdrive EMD
- 3 = TSA 160 NT
- 4 = Powerturn

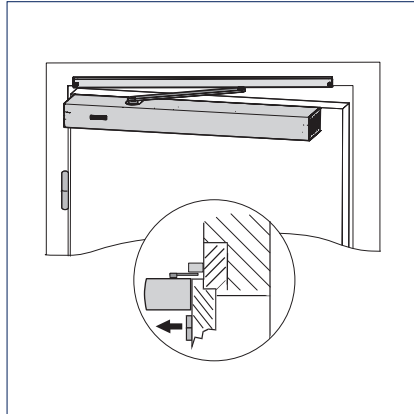

Door leaf installation with guide rail / roller guide rail

- 1 = ECturn
- 2 = Slimdrive EMD
- 3 = Powerturn

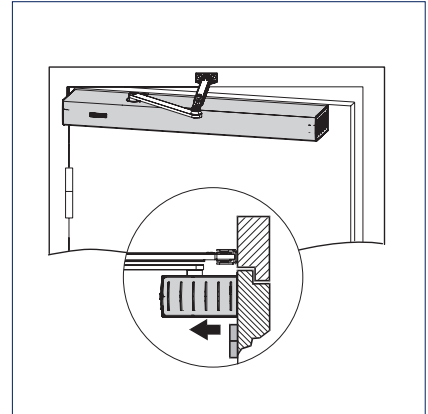

Door leaf installation with link arm

- 1 = ECturn
- 2 = Powerturn

Installation on the opposite hinge side

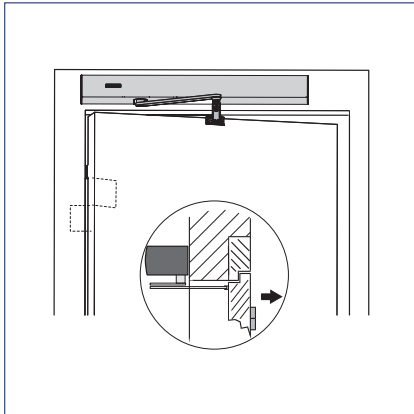

Transom installation with link arm

- 1 = ECturn
- 2 = Slimdrive EMD
- 3 = TSA 160 NT
- 4 = Powerturn

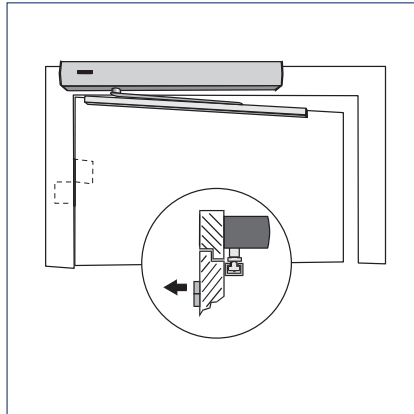

Transom installation with guide rail / roller guide rail

- 1 = ECturn
- 2 = Slimdrive EMD
- 3 = Powerturn

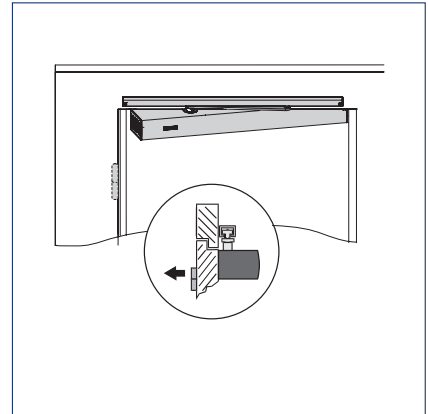

Door leaf installation with guide rail / roller guide rail

- 1 = ECturn
- 2 = Powerturn

Installation in the door leaf / installation in the door frame

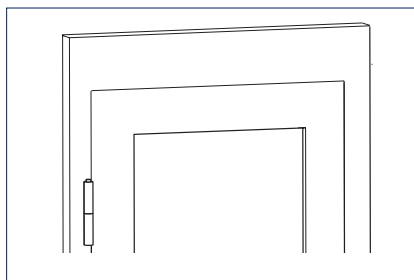

- 1 = ECturn Inside

Swing door systems for fire and smoke protection doors (F)

Drive systems in the F variant are used to automatically open and close 1-leaf fire protection doors. The usual types of impulse generator can be used to actuate the drive. In addition to automatic opening and closing, fire protection doors can also be held open. In the event of a fire, an appropriate fire detection system must cancel the automatic function or any hold-open mechanism. The power supply to the mains cable is interrupted via a mains switch-off board (F-accessory) and the drive retains the normal door closer performance. This means that door closers with automatic opening function in accordance with DIN 18263 Part 4 are a component part of hold-open systems and require official building approval. Fire protection doors must meet the requirements of the DIBt guideline (Deutsches Institut für Bautechnik). The Powerturn F and the Slimdrive EMD-F/R with integrated smoke switch fulfil the highest design requirements.

This variant can be realised using the following drive series: Slimdrive EMD-F, TSA 160 NT and Powerturn

F swing door



Photo: GEZE GmbH

Swing door systems with integrated closing sequence control (IS)

Swing door systems in the IS variant are always equipped with an integrated closing sequence control (electronic or mechanical). The closing sequence control ensures that the fixed leaf closes first on 2-leaf doors. The active leaf only closes once the fixed leaf has closed completely. The mechanical closing sequence control also works without electricity and in the event of a power failure.

This variant can be realised using the following drive series: Slimdrive EMD-F, TSA 160 NT and Powerturn

IS swing Door



Hospital, Düsseldorf, Germany (Photo: Lothar Wels)

Swing door systems with integrated closing sequence control for double-leaf fire and smoke protection doors (F-IS)

Drive systems in the F-IS variant are used to automatically open and close double-leaf fire protection doors. A mechanical closing sequence control is necessary for double-leaf fire protection doors, refer to the section on integrated closing sequence control (IS). This variant can be realised using the following drive series: Slimdrive EMD-F, TSA 160 NT and Powerturn

F-IS swing door



Hospital, Düsseldorf, Germany (Photo: Lothar Wels)

Swing door systems with integrated closing sequence control for double-leaf doors, automatic doors and door closer function (IS/TS)

With this variant for double-leaf swing door systems, the active leaf is automated with a swing door drive and the fixed leaf is equipped with a door closer. Since the drive design is not interrupted, this system produces harmonious results, both in terms of function and appearance. The preferred use for this swing door drive/door closer combination is when the active leaf is the one mainly moved. The closing sequence control required for use on fire protection doors is also integrated in the drive housing. The Powerturn F/R-IS/TS version for hold-open systems combines innovative technology and design since the smoke control unit is invisibly integrated into the cover. This variant can be realised using the following drive series: TSA 160 NT IS/TS and Powerturn IS/TS

F-IS/TS swing door



Danish Association for Disabled, Taastrup, Denmark (Photo: Morten Bak)

Swing door systems for fresh air as well as doors in emergency exits (inverse)

Inversely installed swing door drives are used on single and double-leaf single-action doors made of wood, plastic or steel. There is an electrical closing sequence control available for double-leaf doors. Inversely installed drives are suitable for emergency exits and for fresh air opening systems for RWA systems. The doors are opened by spring force and closed by motor. This guarantees that the door will open safely in the event of a power failure or fire alarm. An emergency power supply is no longer required.

This variant can be realised using the following drive series: Slimdrive EMD and TSA 160 NT

Inverse swing door



Augustinum retirement home, Stuttgart, Germany (Photo: Dirk Wilhelmy)

Swing door systems for large and heavy doors, as well as frequently used doors (EN7)

GEZE swing door drives can be used for the safe and reliable automatic operation of even very large and heavy swing doors with leaf weights of up to 600 kg. The F-version of the drive variants with a closing force size EN7 are suitable and approved for fire protection doors with leaf weights up to 300 kg or with a leaf width of 1600 mm. Optimum areas of application are facilities for the elderly, hospitals, shopping centres, schools or airports.

The closing force size EN7 can be realised with the following drive series: TSA 160 NT EN7 and Powerturn

Powerturn swing door



Photo: GEZE GmbH

Special area of application: Accessible toilet

Accessible toilets must be designed in such a way that people with all sorts of different handicaps can use the facilities without needing help. GEZE swing door drives provide an indispensable service for this application, and guarantee a high level of convenience.

Description of function

The door opens automatically after the elbow switch on the outside of the toilet has been pressed, and closes automatically after the set hold-open time has passed.

When the user presses the selector switch inside the toilet cubicle, the "occupied" sign outside the toilet is activated and the telltale lamp on the change-over switch comes on. At the same time, the elbow switch is deactivated on the outside and on the inside. This means the door cannot be opened by third parties nor by the user by mistake. The door opener is supplied with current, preventing manual opening of the door from outside. When the user leaves the toilet, he presses the selector switch again. The "occupied" sign outside and the telltale lamp inside both go off. The drive is actuated by pressing the OPEN DOOR elbow switch inside the cubicle, and the door opens immediately.

In the event of a power failure, the door opener (electric strike for static current) releases and the user can leave the cubicle by pushing or pulling the door open. The door can also always be opened from the inside by pressing the elbow switch, even when the system is still powered. In emergencies, the door can be opened manually from the outside by means of a key or by actuating the emergency shut-off switch.



- 1 = Swing door drive
- 2 = Isolator (recommended installation height: 1600 mm)
- 3 = „Occupied“ indicator light
- 4 = Elbow switch OPEN DOOR (inside and outside)
- 5 = Emergency pull cord
- 6 = Sensor strip

GEZE swing door drive ECTurn

Electromechanical swing door drive for 1-leaf single-action doors as „entry door solution“ (including all-glass doors)

This extremely quiet electromechanical swing door drive meets the requirements of barrier-free building. It makes life easier and more convenient – particularly for people with mobility problems or little strength. Doors can comfortably be opened automatically or manually and closed automatically. The GEZE ECTurn can be operated both in low-energy mode and in automatic mode in accordance with DIN 18650 / EN 16005. In low-energy mode, the drive moves the swing door at reduced speed. The use of safety sensors to safeguard the system is only necessary in individual cases, taking the user group into account. In automatic mode, however, the swing area of the door must always be safeguarded with safety sensors. An optional rechargeable battery ensures maximum safety even in the event of a power failure. This swing door drive covers all internal application cases. Thanks to the glass guide rail available as an accessory, the ECTurn can also be used on glass doors (glass thickness 8-10 mm). The ECTurn is very flexible and permits all hinge variants, both for DIN left and DIN right doors.



GEZE ECTurn

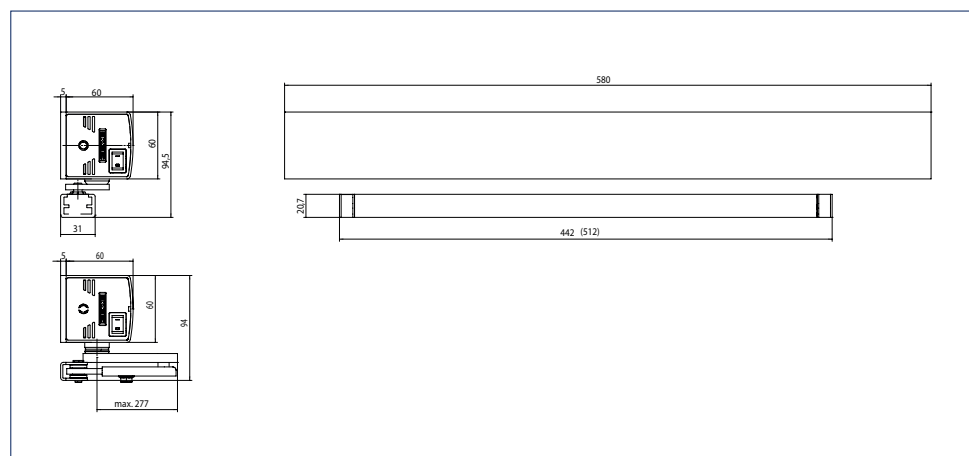

Application range

- Barrier-free entrance doors and internal doors
- All-glass doors
- Hotels and gastronomy
- Hospitals and nursing homes for the elderly
- Educational institutions, e.g. schools, nursery schools, day care centres
- Leisure facilities, e.g. baths, thermal baths, sport and wellness centres
- Administration and public buildings
- Homes

Technical data

Product features	GEZE ECTurn
Height	60 mm
Width	580 mm
Depth	60 mm
Leaf weight (max.) 1-leaf	125 kg
Leaf width (min.-max.)	650 – 1100 mm
Reveal depth (max.)*	200 mm
Door overlap (max.)*	50 mm
Drive type	Electromechanical
Door opening angle (max.)*	110 °
DIN left	•
DIN right	•
Transom installation opposite hinge side with link arm	•
Transom installation opposite hinge side with guide rail	•
Transom installation hinge side with guide rail	•
Transom installation opposite hinge side with guide rail on all-glass doors	•
Transom installation hinge side with guide rail on all-glass doors	•
Door leaf installation opposite hinge side with guide rail	•
Door leaf installation hinge side with guide rail	•
Door leaf installation hinge side with link arm	•
Electrical latching action	•
Disconnection from mains	Main switch in the drive
Activation delay (max.)	10 S
Operating voltage	110 - 230 V
Frequency of supply voltage	50 – 60 Hz
Capacity rating	75 W
Power supply for external consumers (24 V DC)	600 mA
Temperature range**	-15 – 50 °C
IP rating	IP 20
Operating modes	Off, Automatic, Permanently open, Night
Type of function	Fully automatic
Automatic function	•
Low-energy function	•
Key function	•
Obstruction detection	•
Automatic reversing	•
Push & Go	adjustable
Operation	Keypad programme switch TPS, Programme switch integrated in the drive
Parameter setting	Display programme switch DPS, Control
Approvals	DIN 18650, EN 16005

• = Yes

* = Depending on the type of installation

** = The door drive is intended for use in dry rooms only

NOTE: THE MAXIMUM POSSIBLE LEAF WEIGHT IN RELATION TO LEAF WIDTH CAN BE FOUND IN THE CHAPTER ON AREAS OF APPLICATION (DIAGRAMS)!

Areas of application

Note

In low-energy mode the drive moves the swing door at reduced speed, thus fulfilling the safety requirement in DIN 18650 / EN 16005. The use of safety sensors to safeguard the system is only necessary in individual cases, taking the user group into account. In automatic mode, however, the swing area of the door must always be safeguarded with safety sensors.

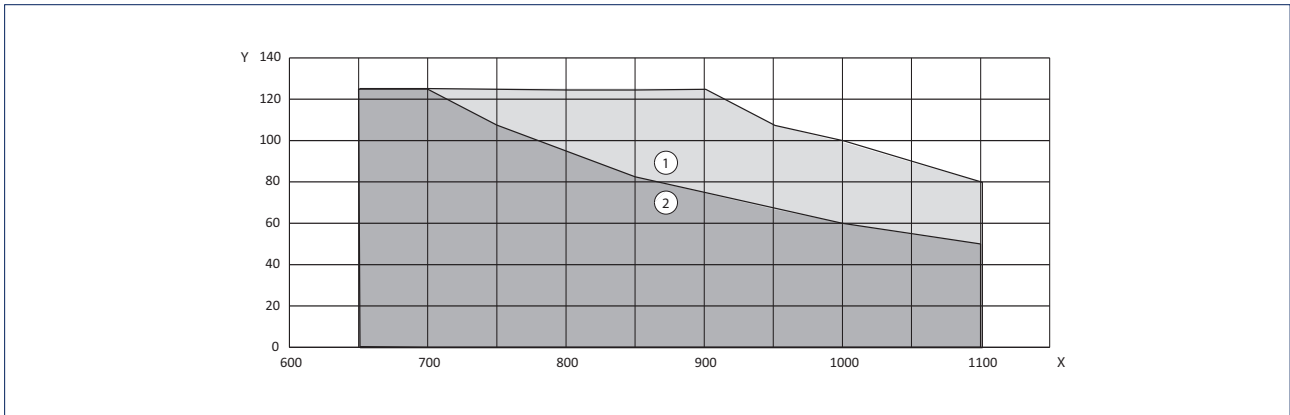

X = Door width (mm)

Y = Door weight (kg)

1 = Area of application in low-energy mode

2 = Area of application in automatic mode



GEZE ECTurn (Photo: Studio BE)

Transom installation with guide rail on the opposite hinge side, single-leaf

Drawing no. 70107-ep02

Reveal depth (max.) 30 mm

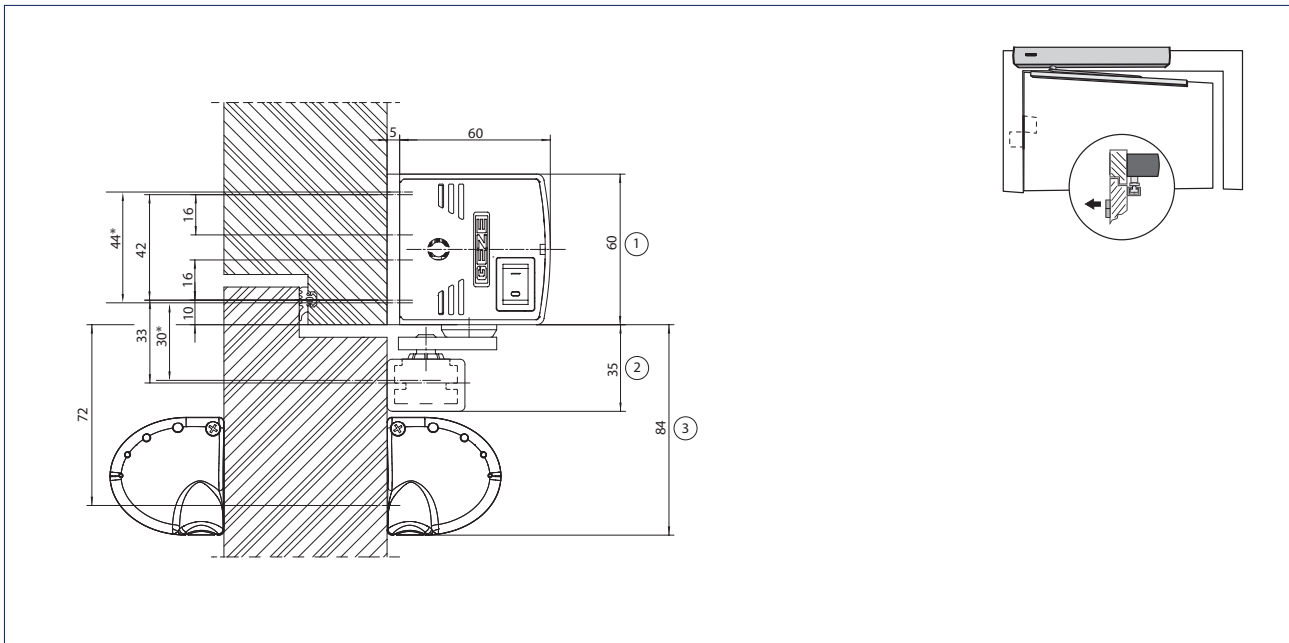

- * = Direct installation
- 1 = Space requirement for ECTurn
- 2 = Space requirement for guide rail
- 3 = Space requirement for sensor strips

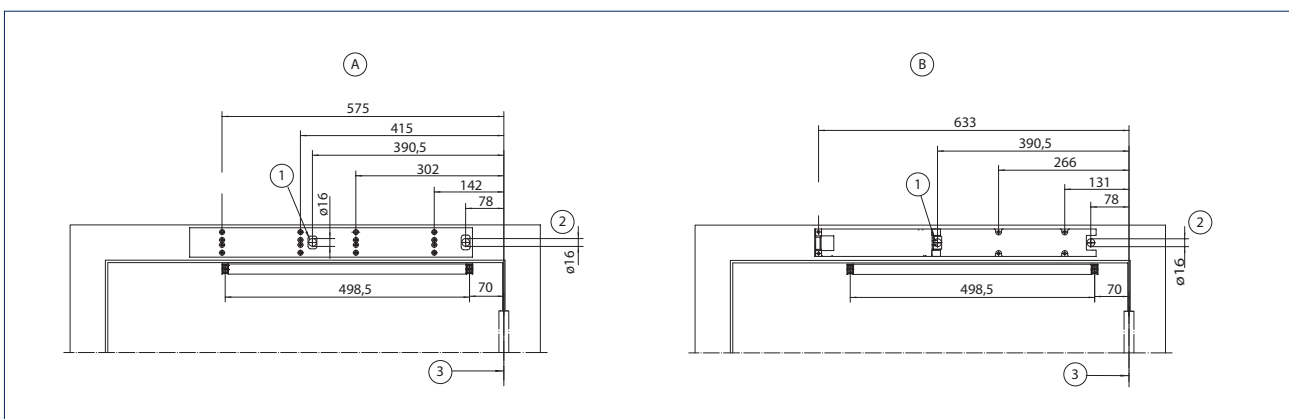
Installation with mounting plate (A) and direct installation (B)

- A = Installation with mounting plate
- B = Direct installation
- 1 = Concealed cable routing for low-voltage connection
- 2 = Concealed cable routing for low-voltage connection and mains cable
- 3 = Dimensional reference centre of hinge

Transom installation with link arm on the opposite hinge side, single-leaf

Drawing no. 70107-ep03

Reveal depth (max.) 200 mm

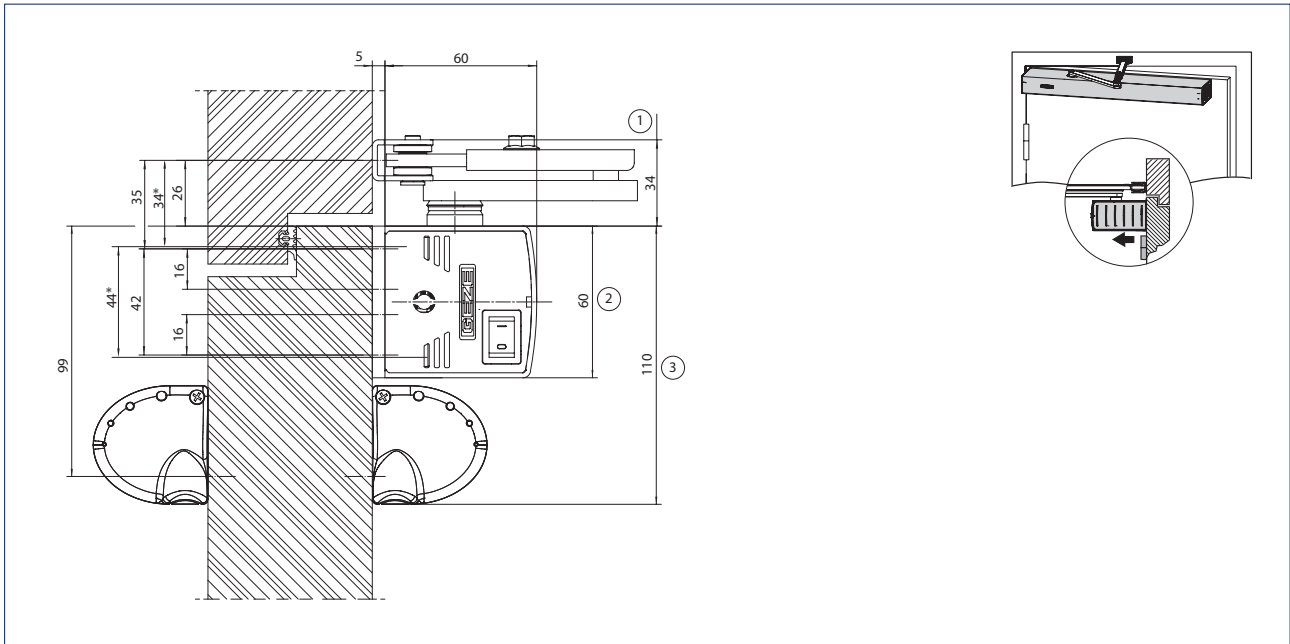

- * = Direct installation
- 1 = Space requirement for ECTurn
- 2 = Space requirement for link arm
- 3 = Space requirement for sensor strips

Installation with mounting plate (A) and direct installation (B)

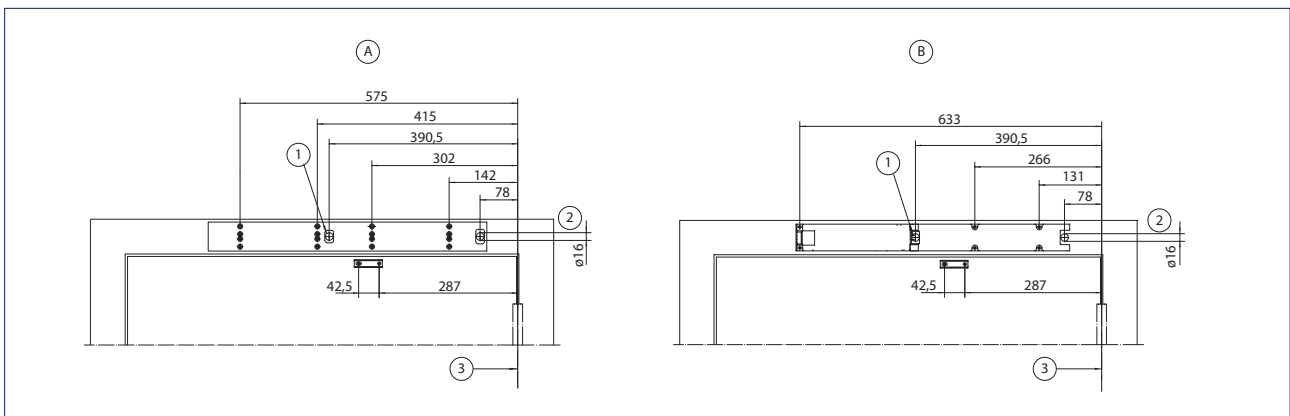

- A = Installation with mounting plate
- B = Direct installation
- 1 = Concealed cable routing for low-voltage connection
- 2 = Concealed cable routing for low-voltage connection and mains cable
- 3 = Dimensional reference centre of hinge

Door leaf installation with guide rail on the hinge side, single-leaf

Drawing no. 70107-ep04

Door overlap (max.) 50 mm

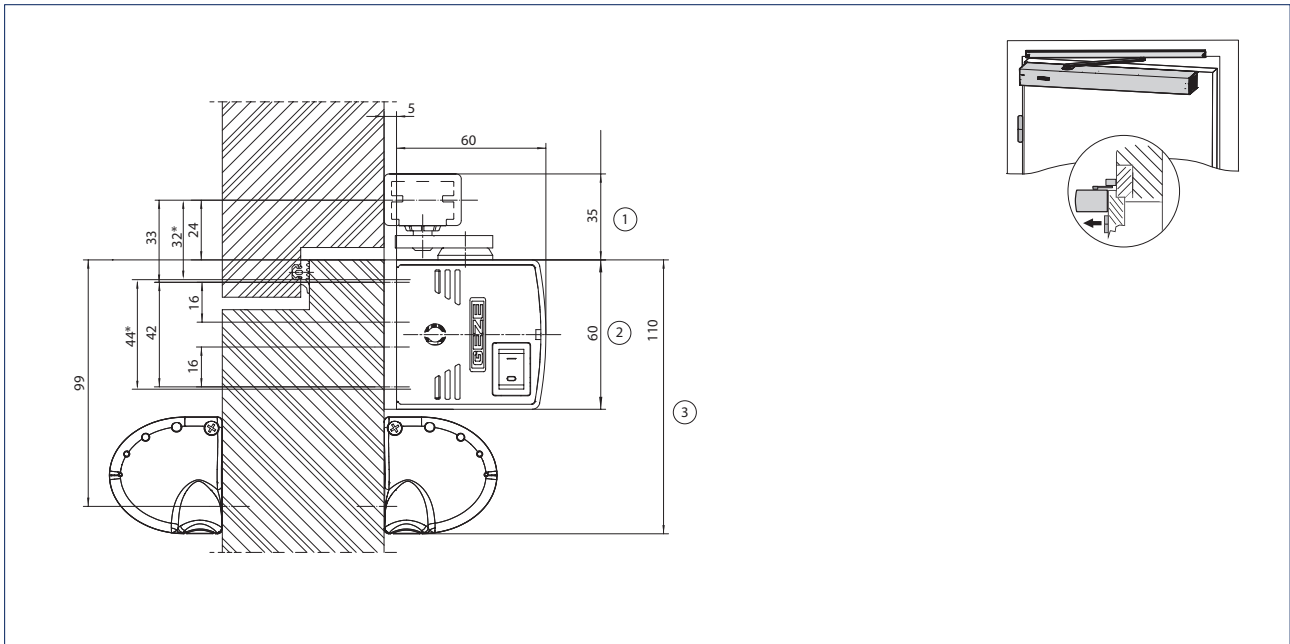

* = Direct installation

1 = Space requirement for guide rail

2 = Space requirement for ECTurn

3 = Space requirement for sensor strips

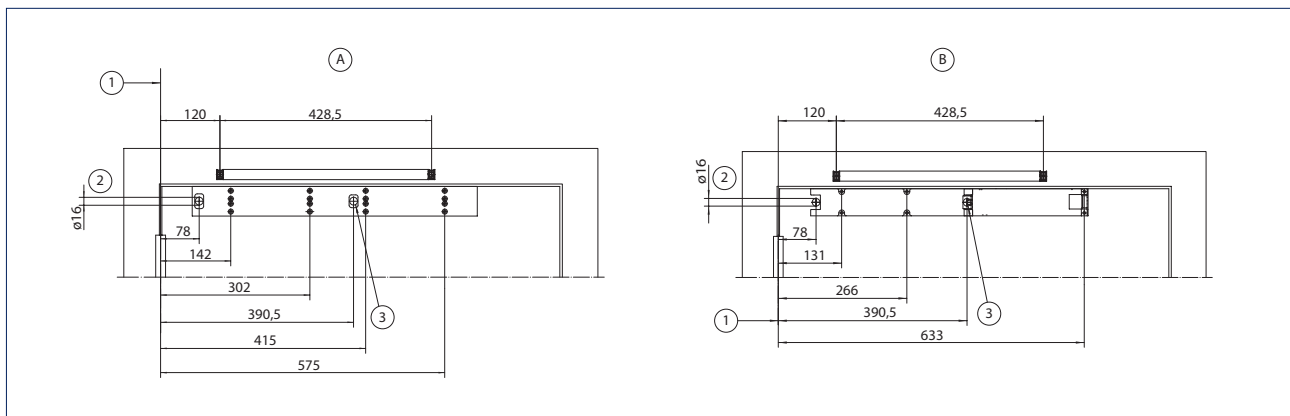
Installation with mounting plate (A) and direct installation (B)

A = Installation with mounting plate

B = Direct installation

1 = Dimensional reference centre of hinge

2 = Concealed cable routing for low-voltage connection and mains cable

3 = Concealed cable routing for low-voltage connection

Door leaf installation with link arm on the hinge side, single-leaf

Drawing no. 70107-ep06

Door overlap (max.) 200 mm

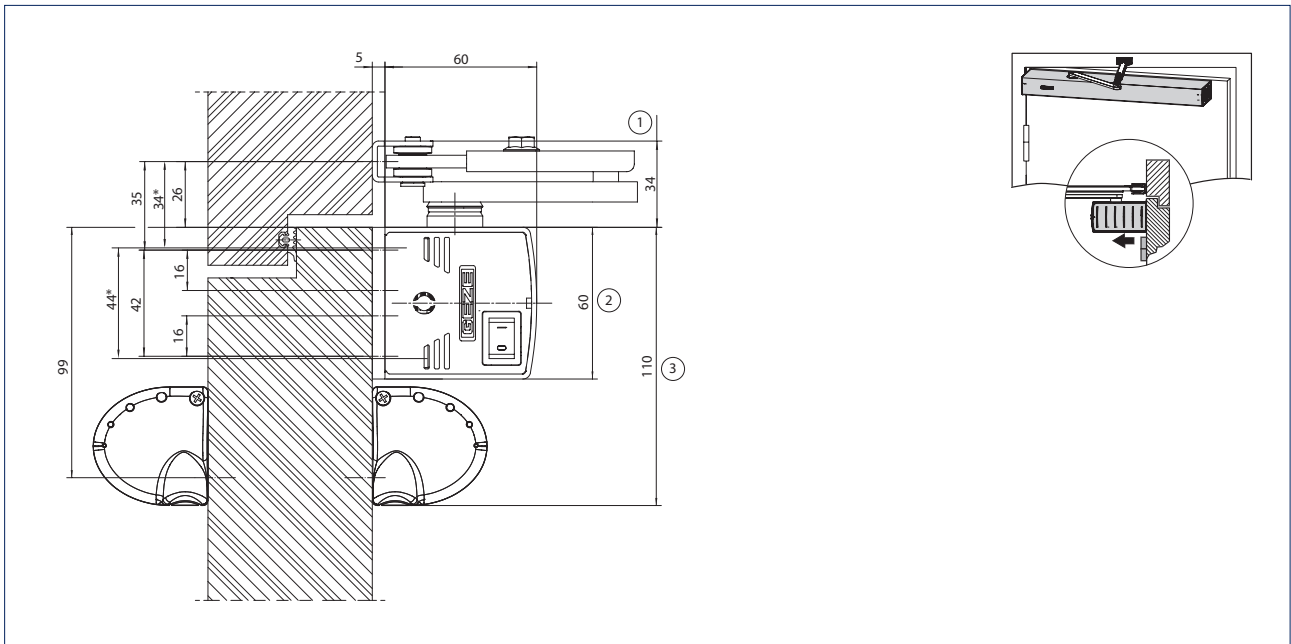

- * = Direct installation
- 1 = Space requirement for link arm
- 2 = Space requirement for Ecturn
- 3 = Space requirement for sensor strips

Installation with mounting plate (A) and direct installation (B)

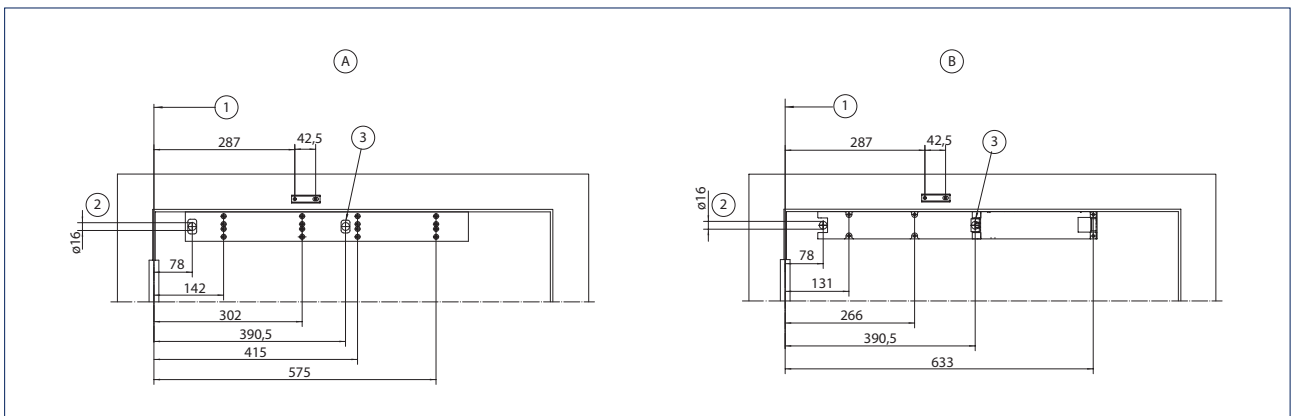

- A = Installation with mounting plate
- B = Direct installation
- 1 = Dimensional reference centre of hinge
- 2 = Concealed cable routing for low-voltage connection and mains cable
- 3 = Concealed cable routing for low-voltage connection

Transom installation with glass guide rail on the hinge side

Drawing no. 70107-ep09

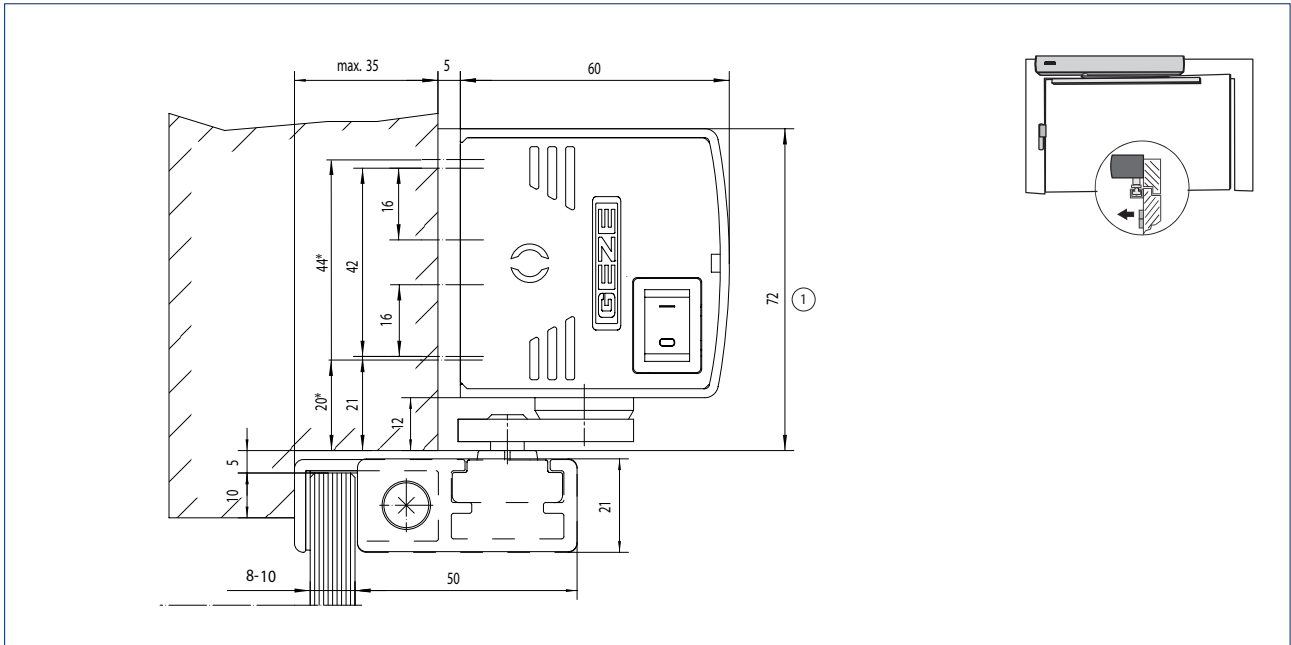

- * = Direct installation
- 1 = Space requirement for Ecturn

Installation with mounting plate (A) and direct installation (B)

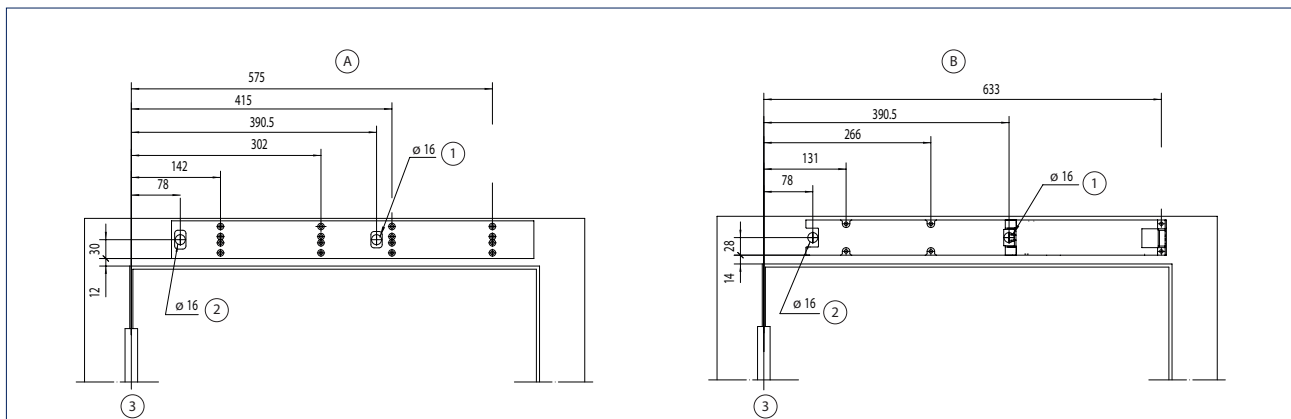

- A = Installation with mounting plate
- B = Direct installation
- 1 = Concealed cable routing for low-voltage connection
- 2 = Concealed cable routing for low-voltage connection and mains cable
- 3 = Dimensional reference centre of hinge

Transom installation with glass guide rail on the opposite hinge side

Drawing no. 70107-ep19

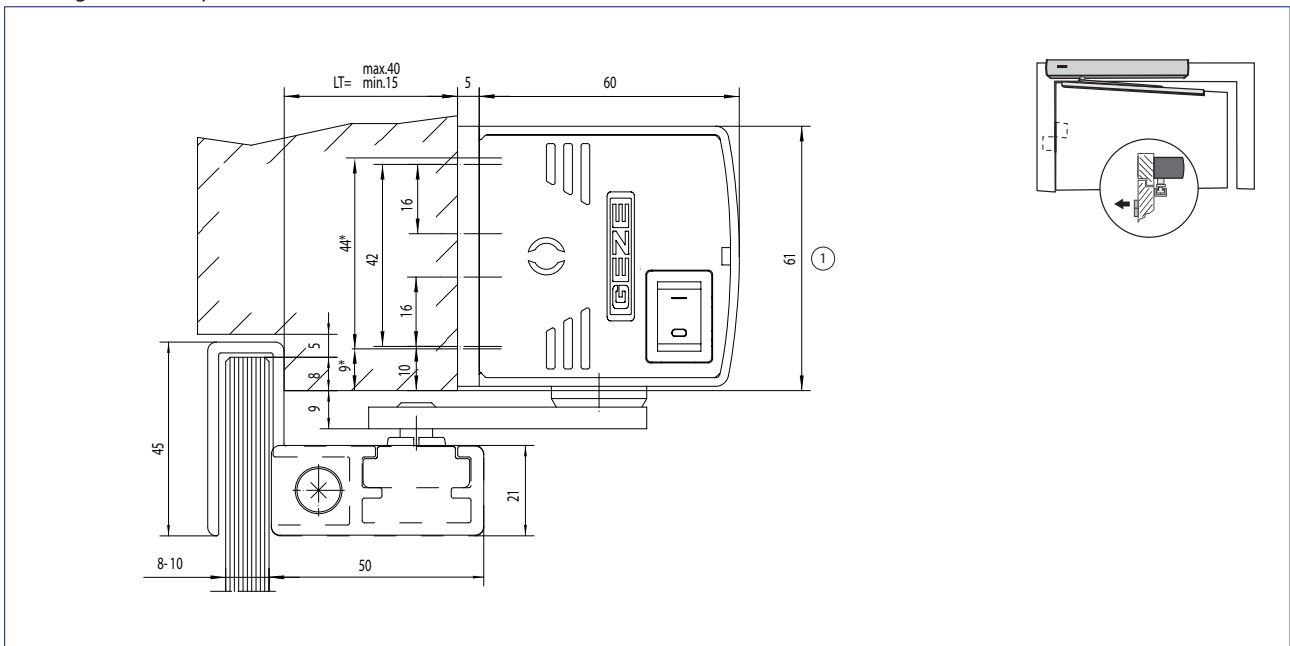

* = Direct installation

1 = Space requirement for ECTurn

LT = Soffit depth

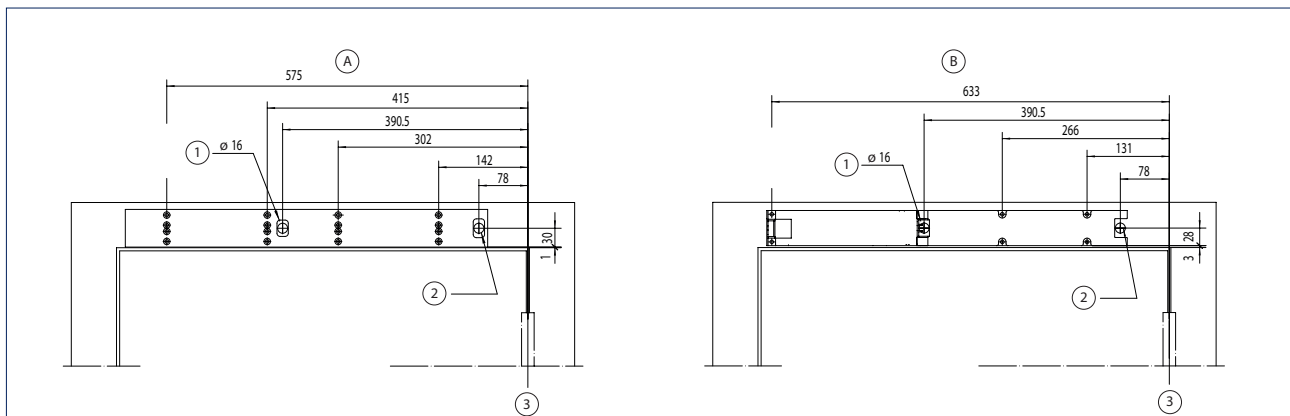
Installation with mounting plate (A) and direct installation (B)

A = Installation with mounting plate

B = Direct installation

1 = Concealed cable routing for low-voltage connection

2 = Concealed cable routing for low-voltage connection and mains cable

3 = Dimensional reference centre of hinge

Legend for the cable plans

Cables

- 1 = NYM-J 3 x 1,5 mm²
- 2 = J-Y(ST)Y 1 x 2 x 0,6 LG
- 3 = J-Y(ST)Y 2 x 2 x 0,6 LG
- 4 = J-Y(ST)Y 4 x 2 x 0,6 LG
- 5 = LiYY 2 x 0,25 mm²
- 6 = LiYY 4 x 0,25 mm²
- 7 = Scope of supply sensor strip or LiYY 5 x 0,25 mm²
- 8 = Route empty pipe with pull-wire inner diameter 10 mm

Abbreviations

- HS = Main switch
- NOT = Emergency-stop switch
- KB = Contact sensor authorised
- PS = Programme switch
- ST = Emergency stop
- KI = Contact sensor inside
- KA = Contact sensor outside
- TOE = Door opener
- RM = Bar message

Notes

- Cable plans can also be prepared for specific building projects after receipt of order
- Version of standard cable plans in accordance with GEZE specifications
- Cable routing according to VDE0100/ IEE regulations
- Allow the cable for the drive to project at least 1500 mm out of the wall

- 1) Door transmission cable (included in the scope of supply for sensor strip)
- 2) Cable exit for door drive, see installation drawings for ECTurn 70107-ep01 to -ep06
- 3) Cable included in the scope of supply for the sensor
- 4) + 5) Connection box for mains supply and control cable combined on site. Mains supply and control cable must be wired in separate terminal spaces.
- 4) Mains connection box WxHxD min. 65 x 65 x 57
- 5) Control cable box WxHxD min. 94 x 65 x 57 with PG-11 duct

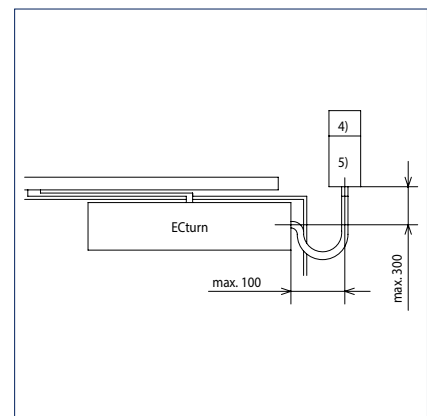
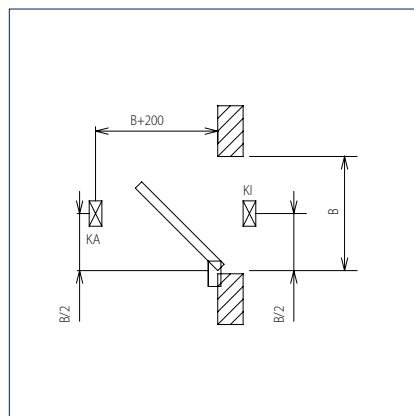
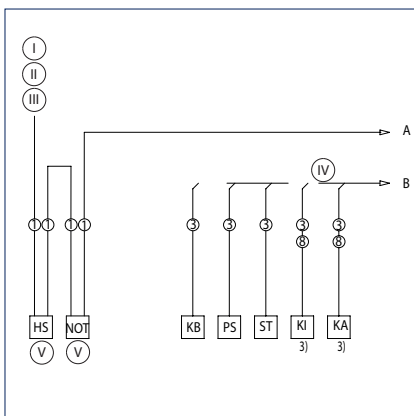

- I = Feeder 230 V / 50 Hz
- II = 10 A fuse
- III = Connected load 230 W 1 A
- IV = And / Or
- V = Option

1-leaf

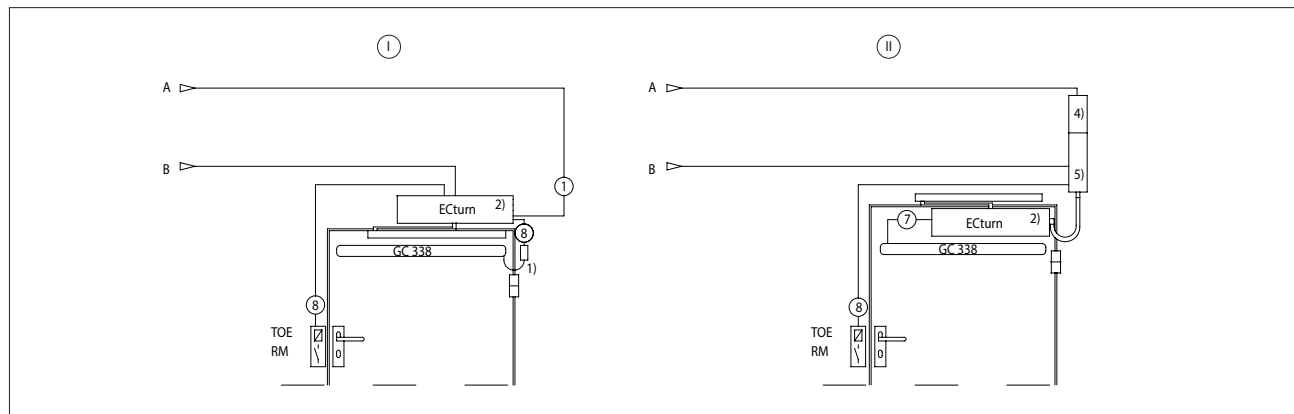

- I = Transom installation concealed cable routing
- II = Door leaf installation

GEZE swing door drive ECTurn Inside

Electromechanical swing door drive for 1-leaf single-action doors as „entry door solution“ and inside

With the ECTurn Inside swing door drive, GEZE combines accessibility and safety with optimum door design. Thanks to its small dimensions, the drive can be integrated into the door leaf of internal doors (min. thickness 55 mm). The ECTurn Inside opens and closes doors “invisibly” without compromising their appearance. The wide range of special functions such as radio push buttons, mobile radio remote control units or acoustic signals allow the system to be tailored to specific user requirements. ECTurn Inside can be operated in low-energy and automatic modes. In low-energy mode the drive moves the swing door at reduced speed, thus fulfilling the safety level of DIN 18650 and EN 16005. An optional rechargeable battery provides a safeguard in the event of a power failure ensuring that the door continues to open automatically and safely. The door can also be opened manually in the event of a power failure.



GEZE ECTurn Inside

Drawing shows installation in wooden door leaf, door frame is reversed (mirror-image)

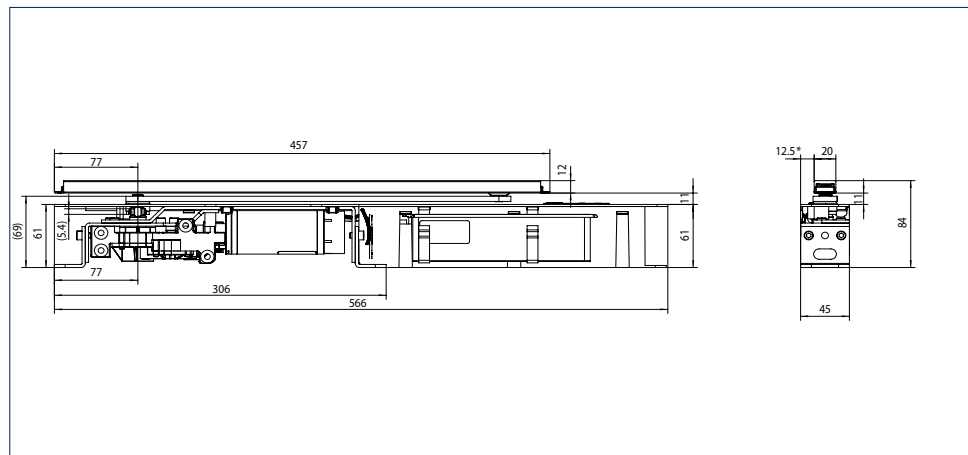

GEZE ECTurn Inside

Drawing shows installation in metal door leaf, door frame is reversed (mirror-image)

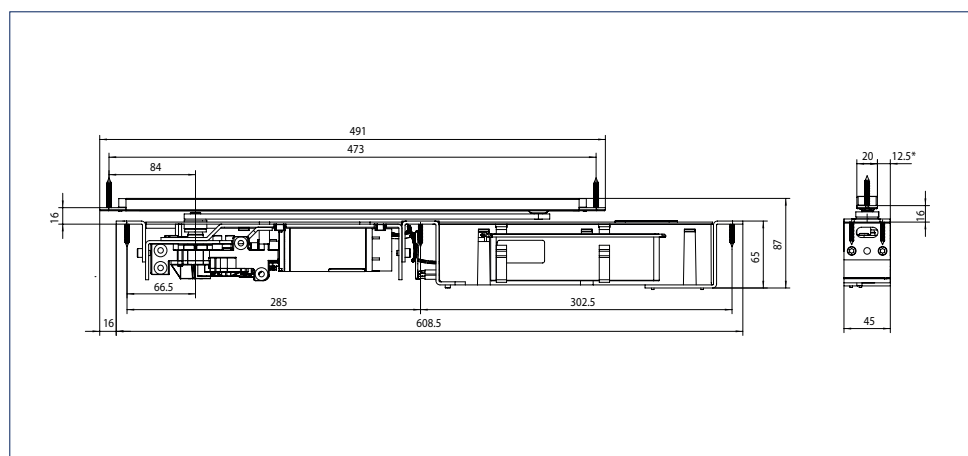

Application range

- Barrier-free entrance doors and internal doors
- Hotels and gastronomy
- Hospitals and nursing homes for the elderly
- Educational institutions, e.g. schools, nursery schools, day care centres
- Leisure facilities, e.g. baths, thermal baths, sport and wellness centres
- Administration and public buildings
- Homes

Technical data

Product features	GEZE ECTurn Inside
Height	61 mm
Width	566 mm
Depth	45 mm
Leaf weight (max.) 1-leaf	125 kg
Leaf width (min.-max.)	700 – 1100 mm
Drive type	Electromechanical
Door opening angle (max.)*	110 °
DIN left	●
DIN right	●
Installation in the door leaf	●
Installation in the door frame	●
Electrical latching action	●
Activation delay (max.)	10 S
Supply voltage	Power supply: 110 - 230 V
Operating voltage	Drive: 24.5 - 30 V DC
Capacity rating	75 W
Power supply for external consumers (24 V DC)	600 mA
Temperature range	-15 – 50 °C
IP rating	IP 20
Operating modes	Off, Automatic, Permanently open, Night
Type of function	Fully automatic
Automatic function	●
Low-energy function	●
Key function	●
Obstruction detection	●
Automatic reversing	●
Push & Go	adjustable
Operation	Programme switch integrated in the drive, Keypad programme switch TPS
Parameter setting	Control, Display programme switch DPS
Approvals	DIN 18650, EN 16005

● = Yes

* = Depending on the type of installation

NOTE: THE MAXIMUM POSSIBLE LEAF WEIGHT IN RELATION TO LEAF WIDTH CAN BE FOUND IN THE CHAPTER ON AREAS OF APPLICATION (DIAGRAMS)!

Areas of application

Note

In low-energy mode the drive moves the swing door at reduced speed, thus fulfilling the safety requirement in DIN 18650 / EN 16005. The use of safety sensors to safeguard the system is only necessary in individual cases, taking the user group into account. In automatic mode, however, the swing area of the door must always be safeguarded with safety sensors.

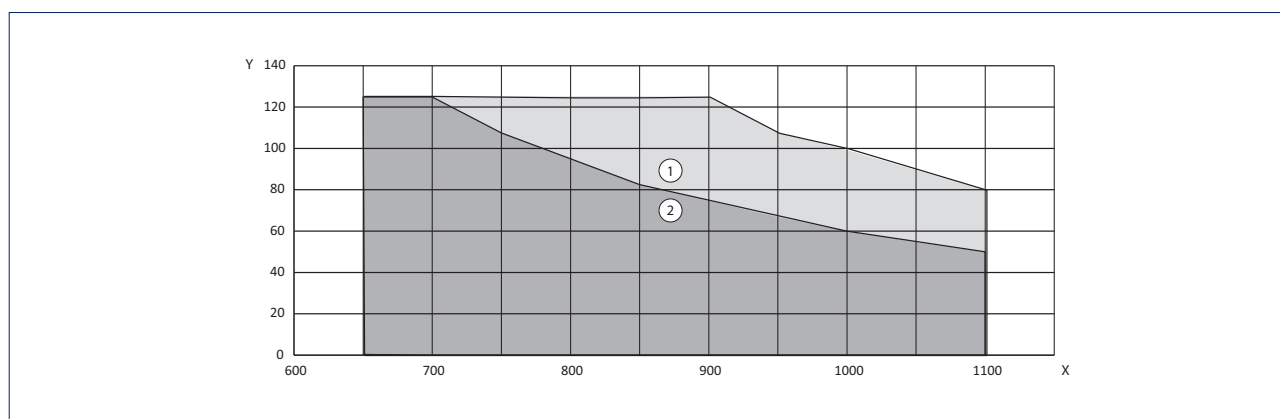

X = Door width (mm)

Y = Door weight (kg)

1 = Area of application in low-energy mode

2 = Area of application in automatic mode

Overview of components

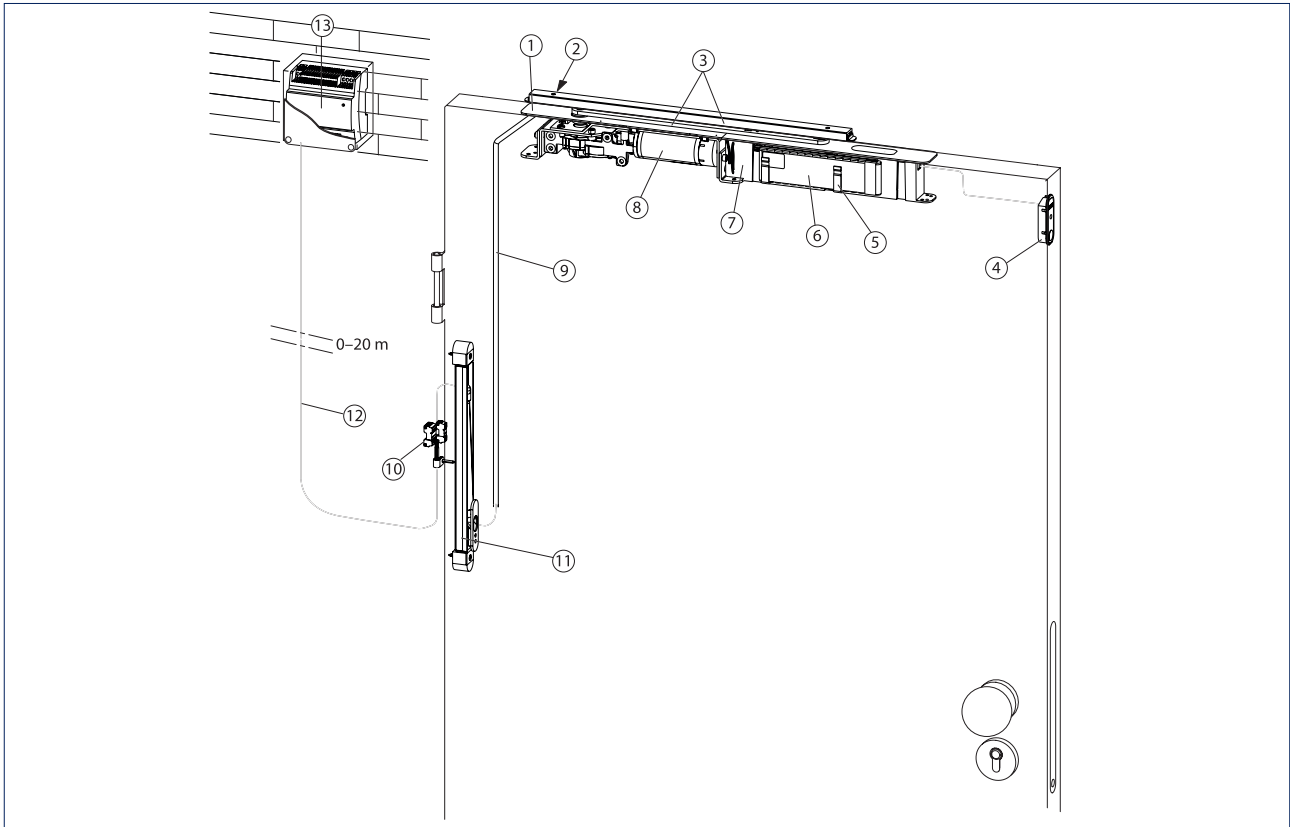

- | | |
|---|-------------------------------------|
| 1 = Cover for the motor drive control | 8 = Motor drive control |
| 2 = Back check | 9 = Supply cable, inside door 2.5 m |
| 3 = Guide rail and lever | 10 = Electric installation material |
| 4 = Separate programme switch (optional) | 11 = Cable transition (optional) |
| 5 = Fixture for rechargeable battery (optional) | 12 = Supply cable (on site) |
| 6 = Rechargeable battery (optional) | 13 = Power supply (flush-mounted) |
| 7 = Control | |

Installation in the wooden door frame

Drawing no. 70107-ep10

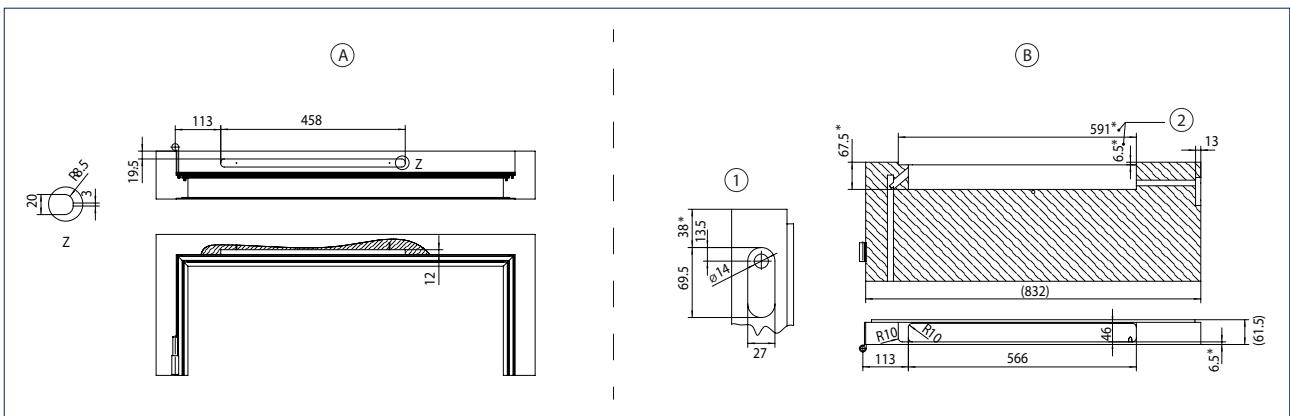

- A = Frame cut-out
 B = Door cut-out
 1 = Recess for programme switch (optional)
 2 = Recess for lever
 * = Dimensions or positions can deviate depending on the door type.

GEZE ECTurn Inside

Installation in the wooden door frame

Drawing no. 70107-ep13

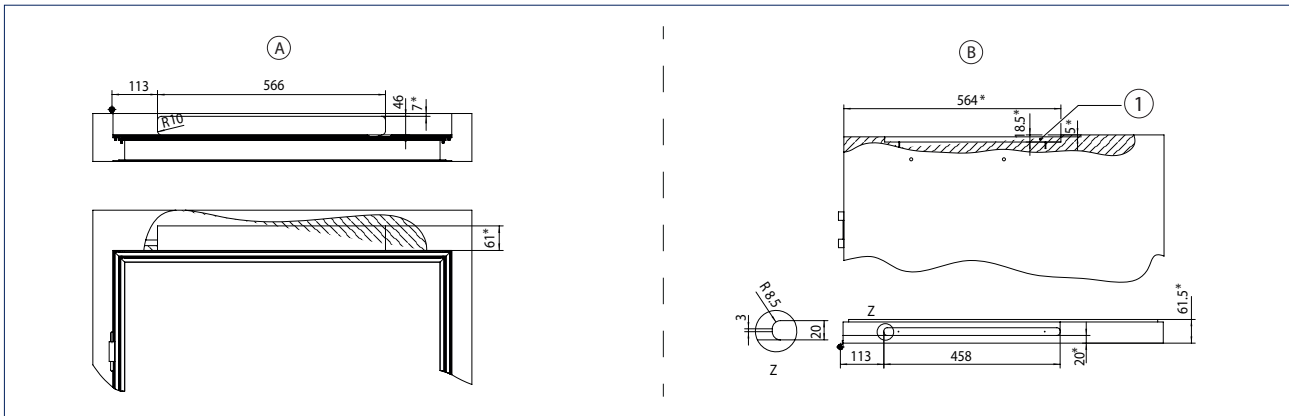

- A = Cut-out for drive
- B = Door cut-out
- 1 = Cut-out for lever
- * = Dimensions or positions can deviate depending on the door type.

Installation in the metal door leaf

Drawing no. 70107-ep12

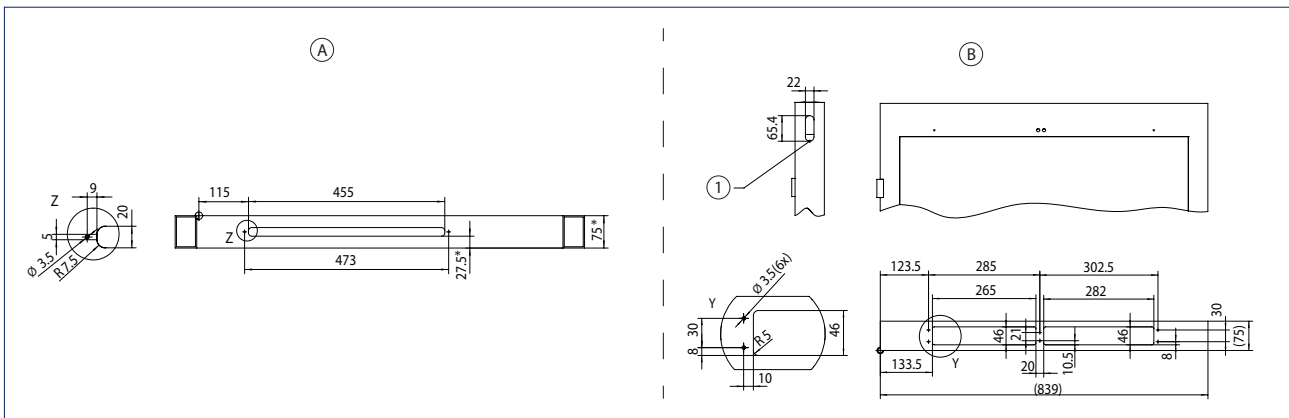

- A = Frame cut-out
- B = Door leaf cut-out
- 1 = Cut-out for programme switch (optional)
- * = Dimensions or positions can deviate depending on the door type.

Installation in the metal door frame

Drawing no. 70107-ep14

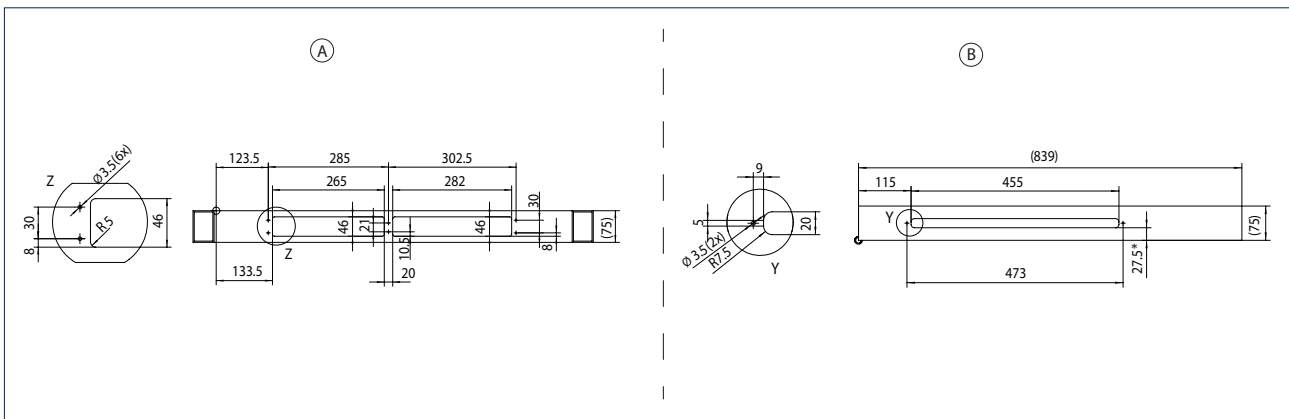

- A = Frame cut-out
- B = Door cut-out
- * = Dimensions or positions can deviate depending on the door type.

Legend for the cable plan

- 1 = NN YM-J 3x1.5 mm²
- 2 = JJ-Y(ST) Y 2x2x0.6 mm²
- 10 = Empty pipe Ø 10 mm with pull-wire; cable supplied by GEZE, max. 3 m
- 11 = Cable information must be provided on site
- 13 = J-Y(ST) Y 2x2x0,6 mm²; optional empty pipe Ø 10 mm with pull-wire
- 16 = Empty pipe Ø 10 mm with pull-wire; J-Y(ST)Y 4x0.6mm LG
- 17 = Empty pipe Ø 12 mm with pull-wire; NYM-O 2x1.5mm2
- 18 = Cable supplied by GEZE, cable length max. 3 m
- i = Cable consolidation for control/activation devices (symbolic)
- RSK = Lock switch contact

Notes

- This cable plan is a simplified symbolic illustration. Connections must be taken from the wiring diagram. Cable routing is included in the VDE guidelines.
- Positioning of the activation and operating devices must be specified on site
- Positions shown with dotted lines are positioned on the opposite side
- In compliance with DIN 18650 / EN 16005 for automatic mode sensor strips on both sides

Standardkabelplan Maximalumfang, einseitig ziehend, 1-flügelig, DIN rechts

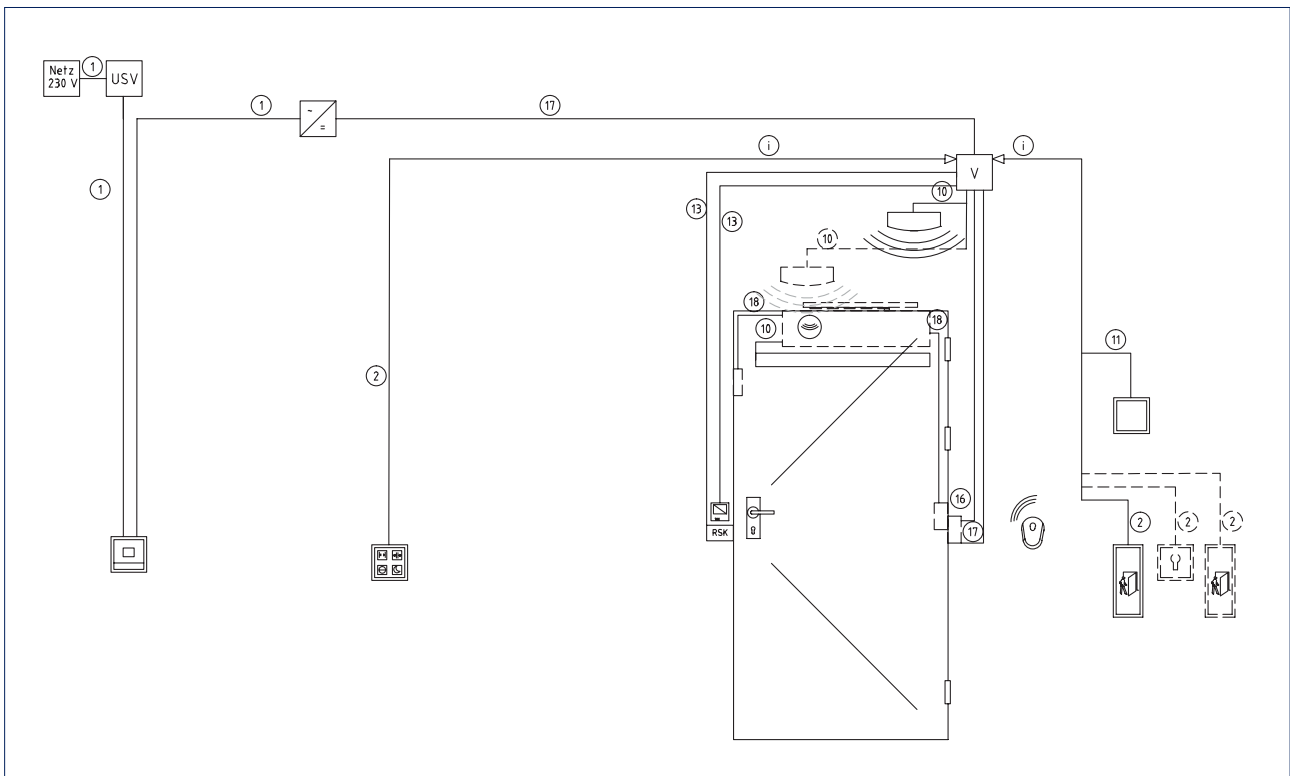

Entry door, private home, Stuttgart, Germany (Photo: GEZE GmbH)

GEZE swing door drive Slimdrive EMD

Electromechanical swing door drive for 1 and 2-leaf single-action doors

The electromechanical swing door drive GEZE Slimdrive EMD stands out due to its numerous areas of application. The compact drive is only 7 cm high and can move large and heavy internal and external doors comfortably and quietly. This makes the Slimdrive EMD the ideal solution wherever efficiency has to be coupled with silent running. State-of-the-art control technology combined with a low-wear and maintenance-free high-power motor guarantees reliable operation even for doors which are heavily frequented. All door parameters e.g. opening and closing speed as well as latching action, can be optimally adapted. Manual door opening can be supported by the drive (servo function) and ensures that even heavy doors can be opened more easily manually. The push & go function can be activated on request, i.e. the door is only slightly opened by hand and the automatic activation opens the door completely. In low-energy mode, the drive moves the door at reduced speed. The optional CAN interface can be used to meet demanding requirements e.g. control units for interlocking door systems.



GEZE Slimdrive EMD

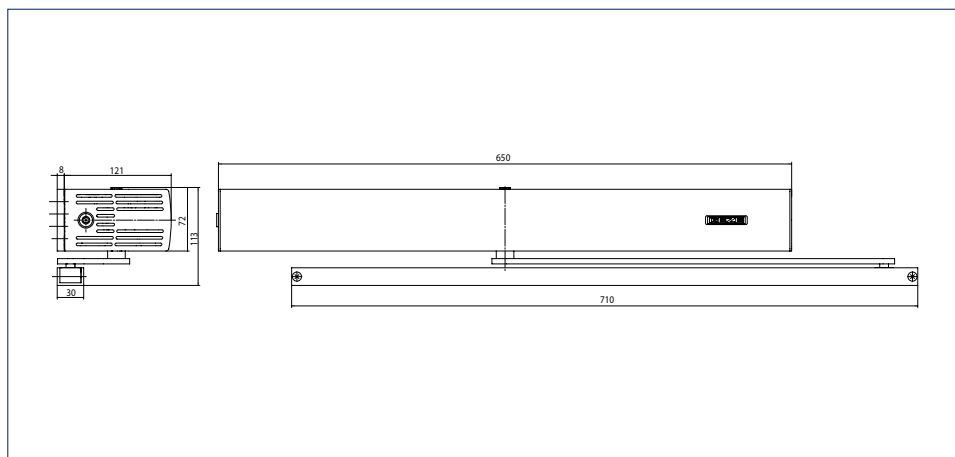

Application range

- Internal and external doors
- Railway stations and airports
- Hotels and gastronomy
- Hospitals and nursing homes for the elderly
- Educational institutions e.g. schools, nursery schools, day care centres
- Leisure facilities, e.g. baths, thermal baths, sport and wellness centres
- Administration and public buildings
- Food industry

Technical data

Product features	GEZE Slimdrive EMD	GEZE Slimdrive EMD-F	GEZE Slimdrive EMD F-IS	GEZE Slimdrive EMD Invers
Height			70 mm	
Width			650 mm	
Depth			121 mm	
Leaf weight (max.) 1-leaf	180 kg		230 kg	
Hinge clearance (min.-max.) 2-leaf			1500 – 2800 mm	
Leaf width (min.-max.)			750 – 1400 mm	
Reveal depth (max.)*			400 mm	
Door overlap (max.)*			30 mm	
Drive type			Electromechanical	
Door opening angle (max.)*			115 °	
Spring pre-load**	-		EN3 – EN6	
DIN left	●	●	●	●
DIN right	●	●	●	●
Transom installation opposite hinge side with link arm	●	●	●	●
Transom installation opposite hinge side with roller guide rail	●	●	●	●
Transom installation hinge side with roller guide rail	●	●	●	●
Door leaf installation hinge side with roller guide rail	●	●	-	●
Mechanical latching action	-	●	●	-
Electrical latching action	●	●	●	●
Electrical closing sequence control	●	●	●	●
Mechanical closing sequence control	-	-	●	-
Disconnection from mains			Cable plug connection	
Activation delay (max.)			20 S	
Operating voltage			230 V	
Frequency of supply voltage			50 – 60 Hz	
Capacity rating			230 W	
Power supply for external consumers (24 V DC)			1200 mA	
Temperature range****			-15 – 50 °C	
IP rating			IP 20	
Operating modes			Off, Automatic, Permanently open, Shop closing, Night	
Type of function			Fully automatic	
Automatic function	●	●	●	●
Low-energy function	●	●	●	-
Servo function	-	●	●	●
Key function	●	●	●	●
Inverse function (opening by spring force)	-	-	-	●
Vestibule function	●	●	●	●
Obstruction detection	●	●	●	●
Automatic reversing	●	●	●	●
Push & Go			adjustable	
Operation			Display programme switch DPS	
Parameter setting			Display programme switch DPS	
CAN interface			optional	
Approvals	DIN 18650 EN 16005	DIN 18650 DIN 18263-4 EN 16005	DIN 18650 DIN 18263-4 Door closing sequence selector tested in accordance with EN 1158 EN 16005	DIN 18650 EN 16005
Suitable for fire protection doors	-	●***	●	-
Integrated smoke switch (R-variant)	-	●***	●	-

● = Yes

* = Depending on the type of installation

** = See table Overview of torques

*** = Types of installation: transom installation hinge side with roller guide rail / transom installation opposite hinge side with link arm

**** = The door drive is intended for use in dry rooms only

NOTE: THE MAXIMUM POSSIBLE LEAF WEIGHT IN RELATION TO LEAF WIDTH CAN BE FOUND IN THE CHAPTER ON AREAS OF APPLICATION (DIAGRAMS)!

Overview of torques Slimdrive EMD-F

Type of Installation	Transom Installation hinge side (min.-max.)	Door leaf Installation hinge side (min.-max.)	Transom Installation opposite hinge side (min.-max.)	
Linkage element	roller guide rail	roller guide rail	roller guide rail	link arm
Spring pre-load Closer size EN 1154	4 - 5	5	3 - 5	4 - 6
Closing torques	20 - 45 Nm	17 - 43 Nm	20 - 45 Nm	35 - 70 Nm
Opening torques, automatic	122 - 97 Nm	125 - 96 Nm	115 - 90 Nm	max. 150 Nm
Opening torques, manual	45 - 66 Nm	50 - 73 Nm	42 - 65 Nm	61 - 88 Nm

Note: For automatic mode, the doors must be equipped with suitable hinges. A door stop is necessary.

For fire protection doors only the following types of installation: transom installation hinge side with roller guide rail / transom installation opposite hinge side with link arm

EMD, EMD-F, EMD Invers

1-leaf doors	Leaf width (min.)	Leaf width (max.)
Transom installation hinge side with guide rail	850 mm	1250 mm / 1400* mm
Transom installation opposite hinge side with guide rail	850 mm	1250 mm / 1400* mm
Transom installation opposite hinge side with link arm	750 mm	1400 mm

* Not suitable for fire protection doors!

EMD, EMD-F, EMD F-IS, EMD Invers

2-leaf doors	Hinge clearance (min.)	Hinge clearance (max.)	Leaf width (min.) active leaf / fixed leaf	Leaf width (max.)
Transom installation hinge side / opposite hinge side with guide rail	1700 mm	2500 / 2800* mm	850 mm	1250 / 1400* mm
Transom installation opposite hinge side with link arm	1500 mm	2500 / 2800* mm	750 mm	1250 / 1400* mm

* Not suitable for fire protection doors!

Areas of application

Note

In low-energy mode the drive moves the swing door at reduced speed, thus fulfilling the safety requirement in DIN 18650 / EN 16005. The use of safety sensors to safeguard the system is only necessary in individual cases, taking the user group into account. In automatic mode, however, the swing area of the door must always be safeguarded with safety sensors.

Slimdrive EMD

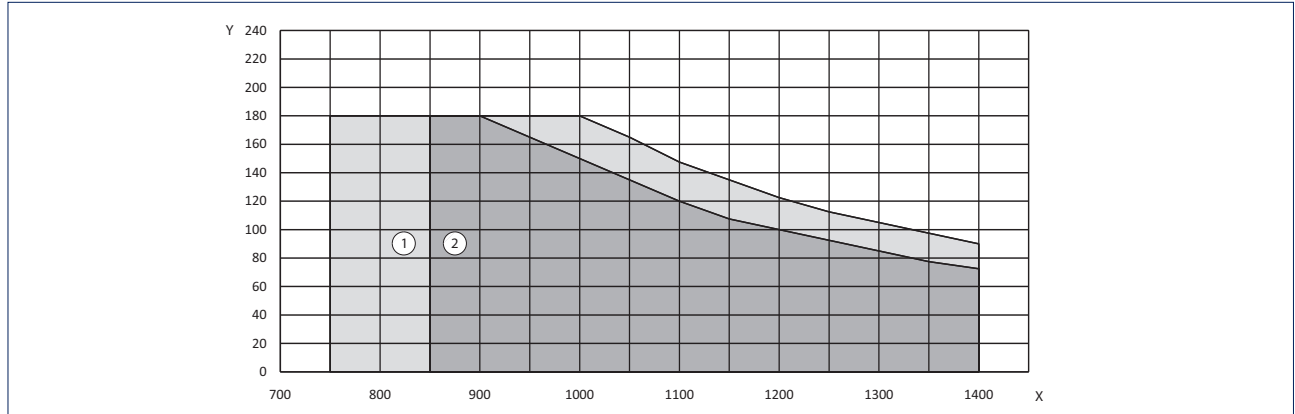

- X = Door width (mm)
- Y = Door weight (kg)
- 1 = Link arm
- 2 = Roller guide rail

Slimdrive EMD-F

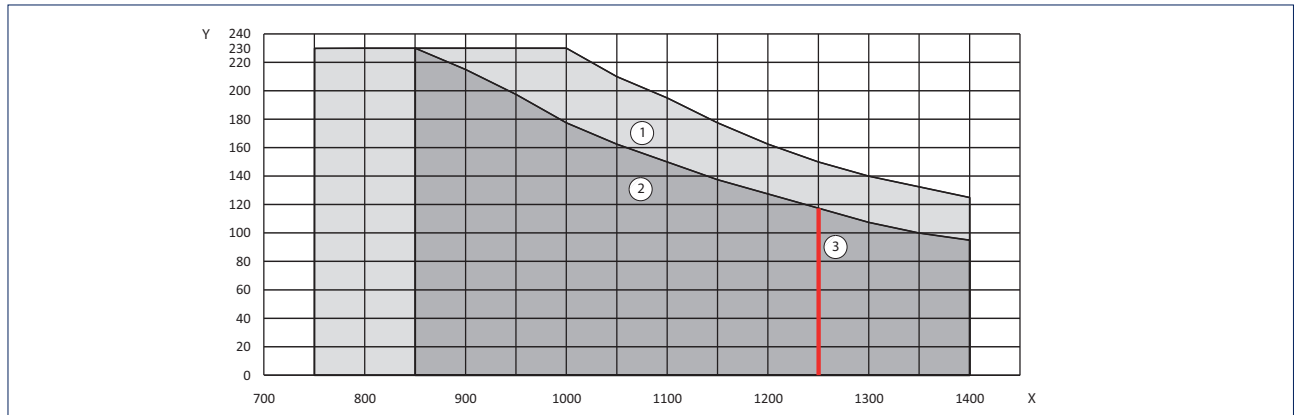

- X = Door width (mm)
- Y = Door weight (kg)
- 1 = Link arm
- 2 = Roller guide rail
- 3 = Use of fire protection limit for roller guide rail

Note

We recommend the use of link arms for external doors. Wind loads and underpressure or excess pressure must also be taken into account. Dimensions marked by an asterisk (*) are valid for direct attachment.

Note: Diagram shows left-hand (ISO 6), right-hand (ISO 5) is reversed (mirror-image).

GEZE SLIMDRIVE EMD

Transom installation with roller guide rail on the hinge side, single-leaf

Drawing no. 70106-ep01

Door overlap (max.) 30 mm

Door opening angle (max.) 105°

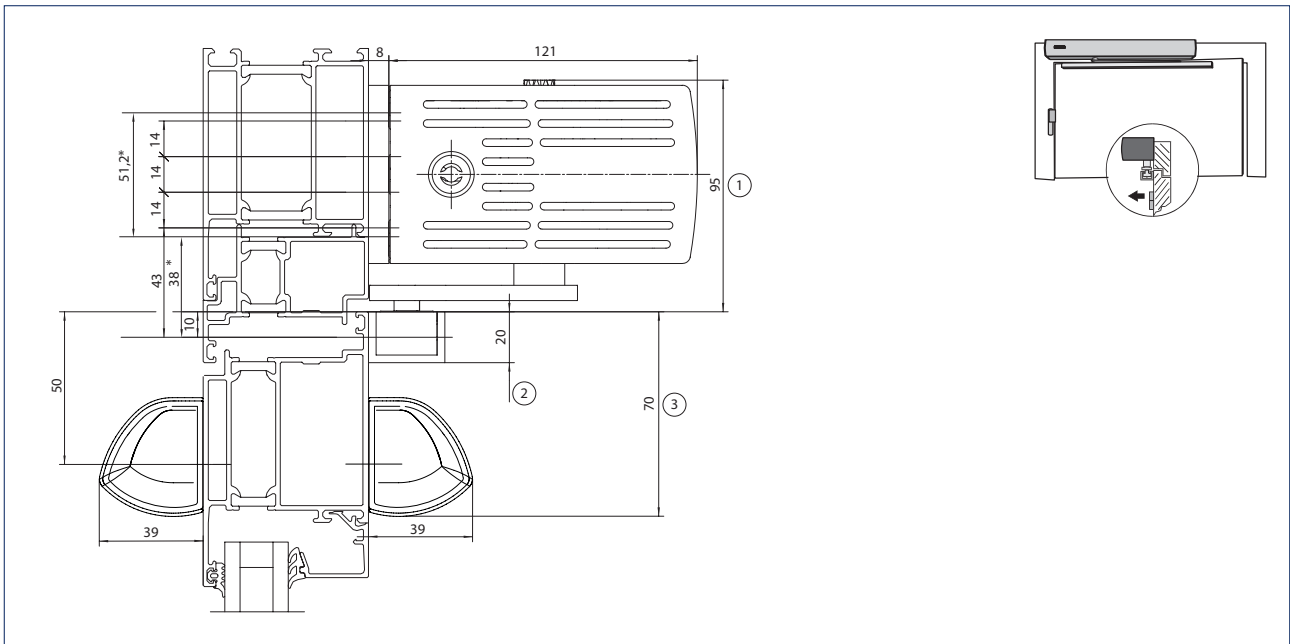

- * = Direct installation
- 1 = Space requirement for EMD-F/EMD Invers
- 2 = Space requirement for roller guide rail
- 3 = Space requirement for sensor strips

Installation with mounting plate (A) and direct installation (B)

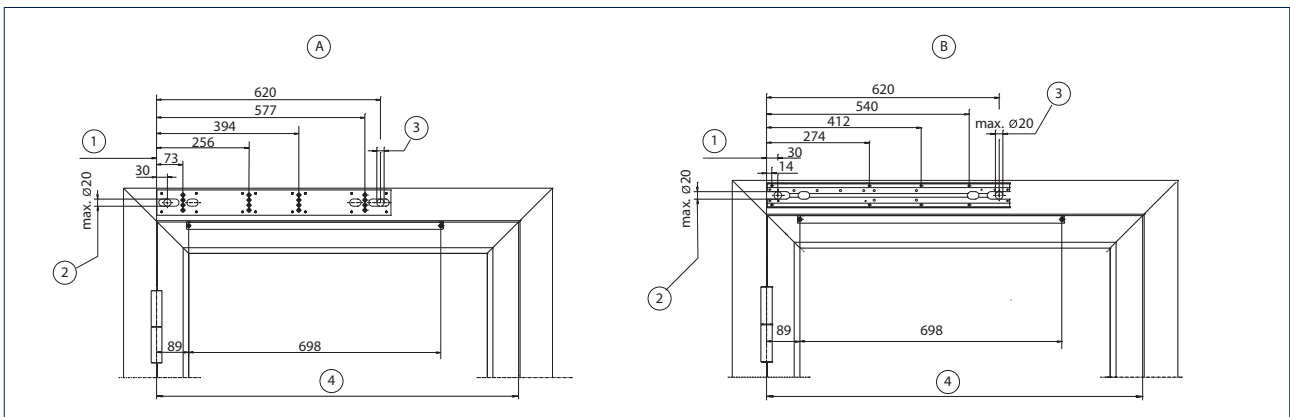

- A = Installation with mounting plate
- B = Direct installation
- 1 = Dimensional reference centre of hinge
- 2 = Concealed cable routing for sensors, door opener, programme switch and lock switch contact
- 3 = Concealed cable routing 230 V / 50 Hz
- 4 = Door leaf width

Transom installation with roller guide rail on the opposite hinge side, single-leaf

Drawing no. 70106-ep02

Reveal depth (max.) -30 to +50 mm

Door opening angle (max.) 105°

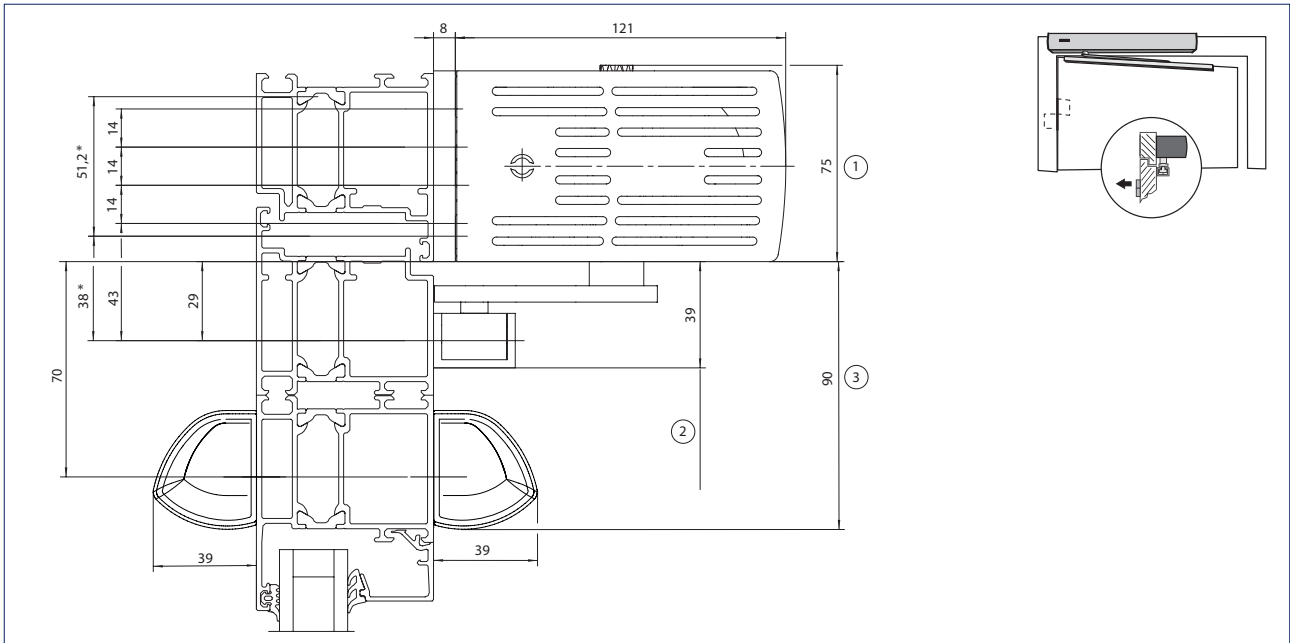

- * = Direct installation
- 1 = Space requirement for EMD-F/EMD Invers
- 2 = Space requirement for roller guide rail
- 3 = Space requirement for sensor strips

Installation with mounting plate (A) and direct installation (B)

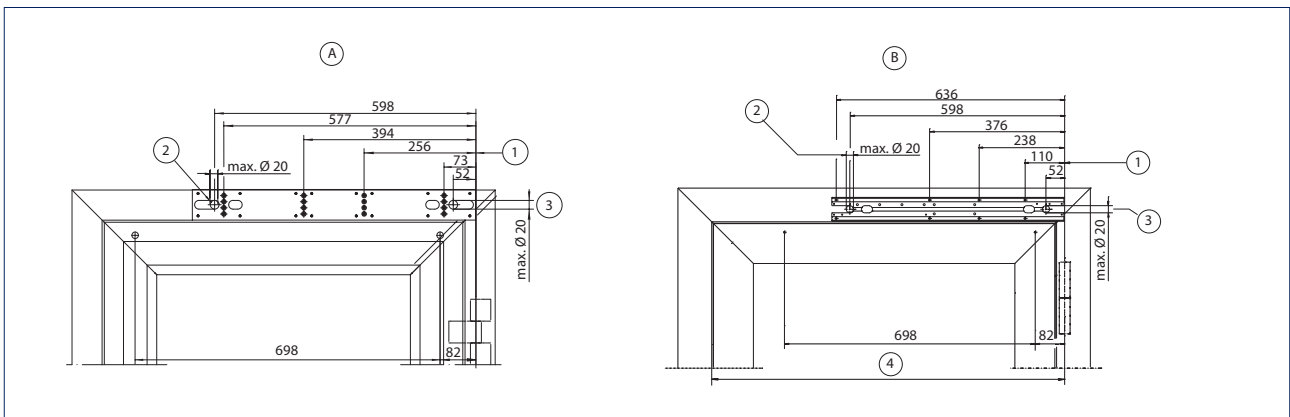

- A = Installation with mounting plate
- B = Direct installation
- 1 = Dimensional reference centre of hinge
- 2 = Concealed cable routing for sensors, door opener, programme switch and lock switch contact
- 3 = Concealed cable routing 230 V / 50 Hz
- 4 = Door leaf width

GEZE SLIMDRIVE EMD

Transom installation with link arm on the opposite hinge side, single-leaf

Drawing no. 70106-ep03

Reveal depth (max.) 0-100 mm, 100-200 mm, 200-300 mm

Door opening angle (max.) 110°

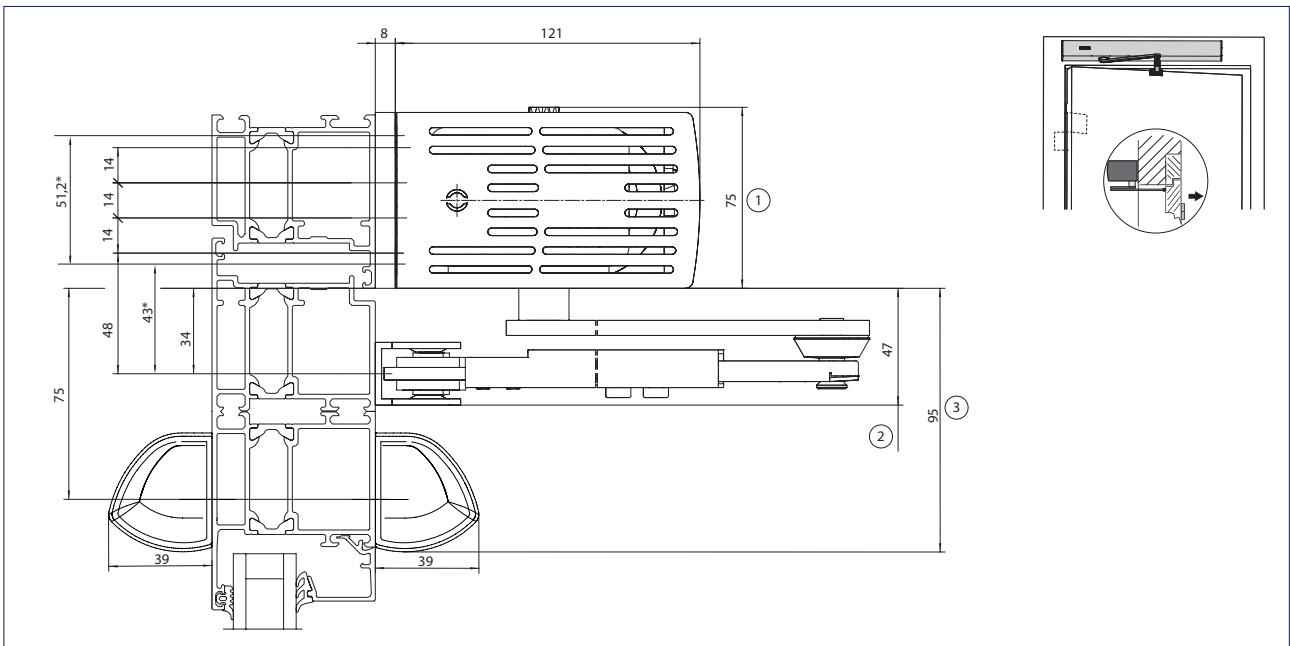

- * = Direct installation
- 1 = Space requirement for EMD-F/EMD Invers
- 2 = Space requirement for link arm
- 3 = Space requirement for sensor strips

Installation with mounting plate (A) and direct installation (B)

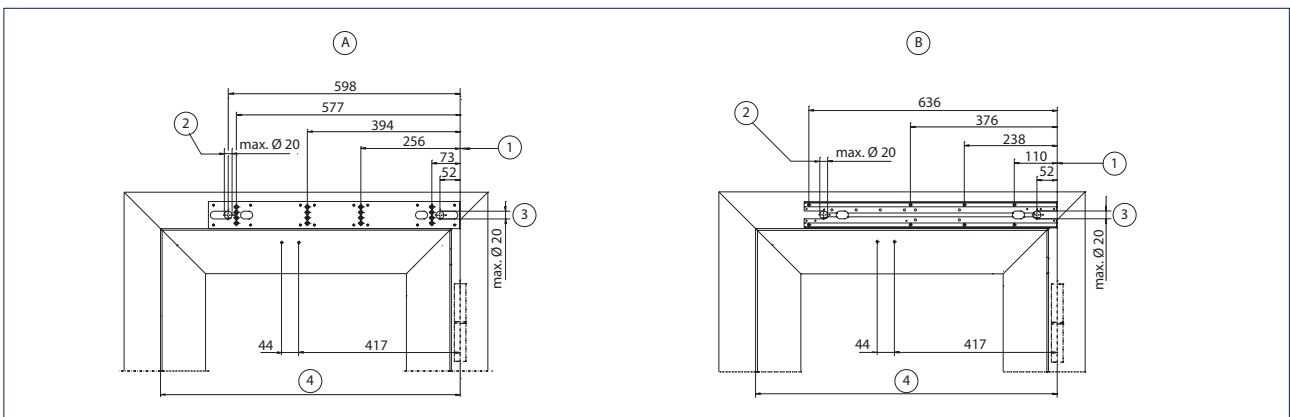

- A = Installation with mounting plate
- B = Direct installation
- 1 = Dimensional reference centre of hinge
- 2 = Concealed cable routing for sensors, door opener, programme switch and lock switch contact
- 3 = Concealed cable routing 230 V / 50 Hz
- 4 = Door leaf width

Door leaf installation with roller guide rail on the hinge side, single-leaf

Drawing no. 70106-ep04

Door overlap (max.) 30 mm

Door opening angle (max.) 115°

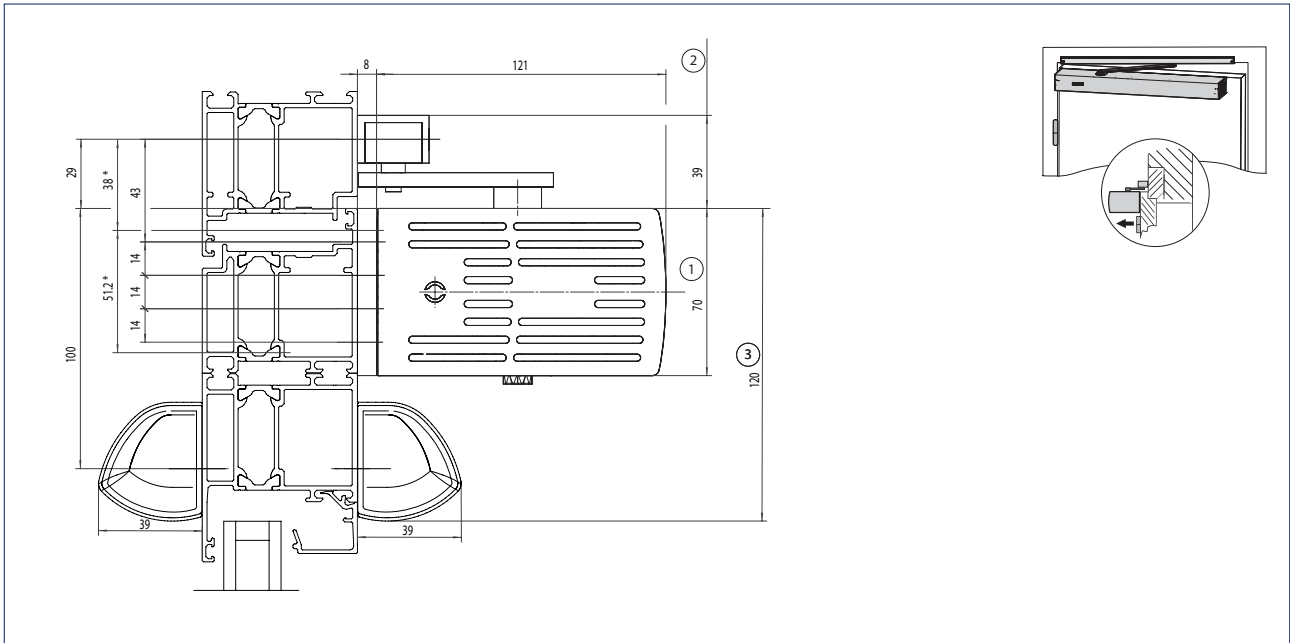

- * = Direct installation
- 1 = Space requirement for EMD-F/EMD Invers
- 2 = Space requirement for roller guide rail
- 3 = Space requirement for sensor strips

Installation with mounting plate (A) and direct installation (B)

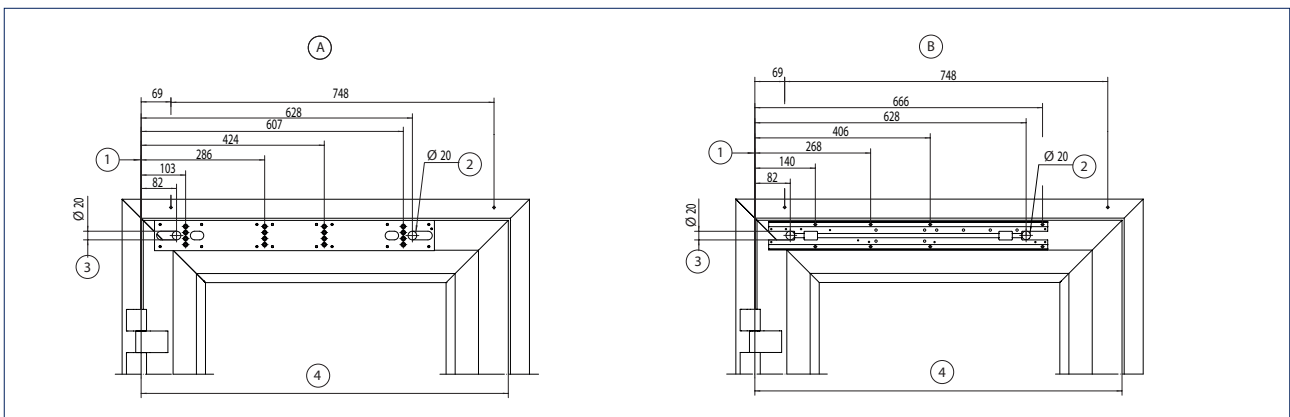

- A = Installation with mounting plate
- B = Direct installation
- 1 = Dimensional reference centre of hinge
- 2 = Concealed cable routing for sensors, door opener, programme switch and lock switch contact
- 3 = Concealed cable routing 230 V / 50 Hz
- 4 = Door leaf width

Transom installation with roller guide rail on the hinge side, double-leaf

Drawing no. 70106-ep21

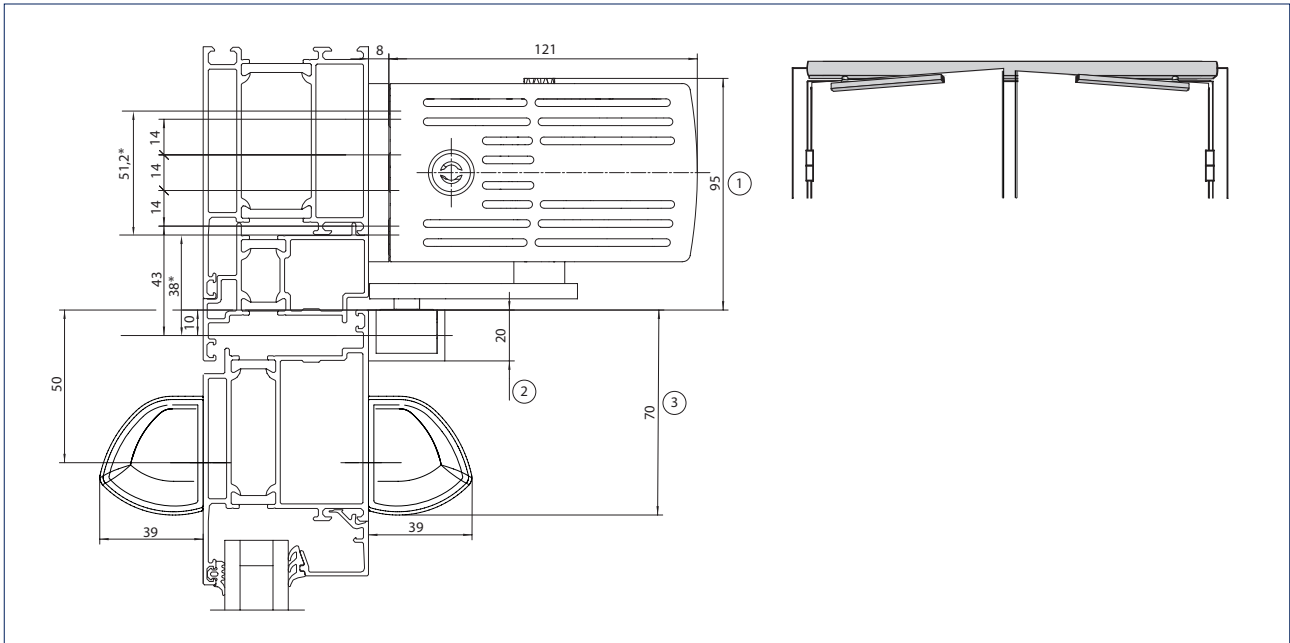

- * = Direct installation
- 1 = Space requirement for EMD-F/EMD Invers
- 2 = Space requirement for roller guide rail
- 3 = Space requirement for sensor strips

Installation with mounting plate (A) and direct installation (B)

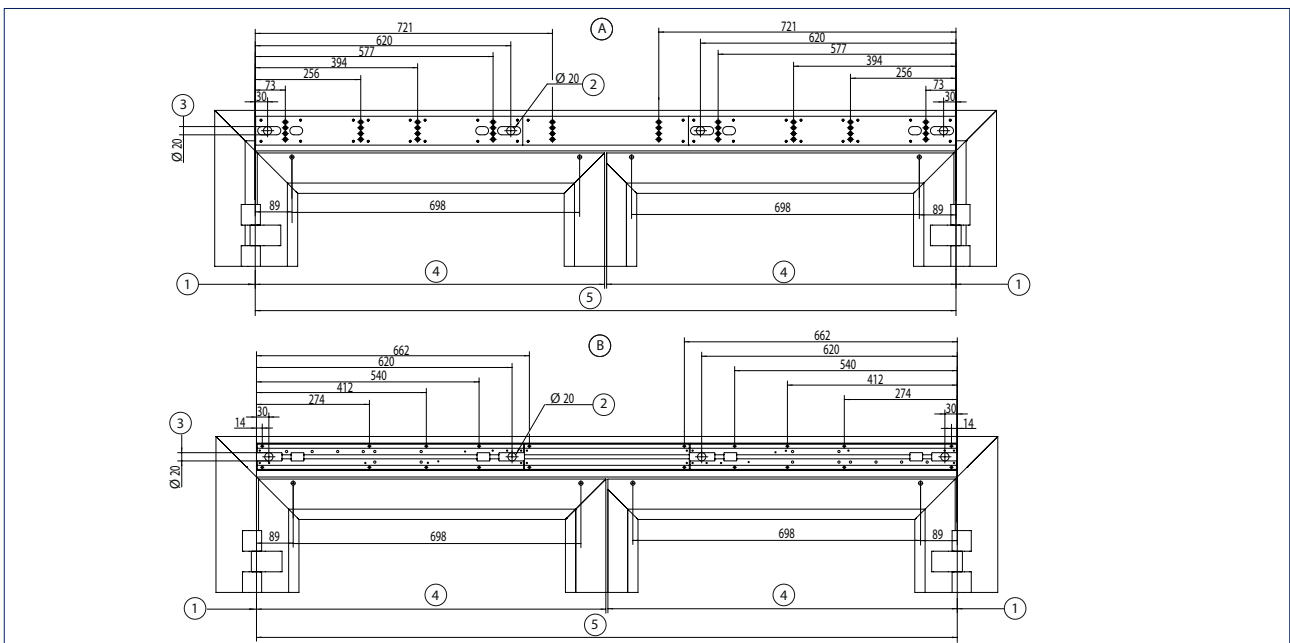

- A = Installation with mounting plate
- B = Direct installation
- 1 = Dimensional reference centre of hinge
- 2 = Concealed cable routing for sensors, door opener, programme switch and lock switch contact
- 3 = Concealed cable routing 230 V / 50 Hz
- 4 = Door leaf width
- 5 = Hinge clearance

Transom installation with roller guide rail on the opposite hinge side, double-leaf

Drawing no. 70106-ep22

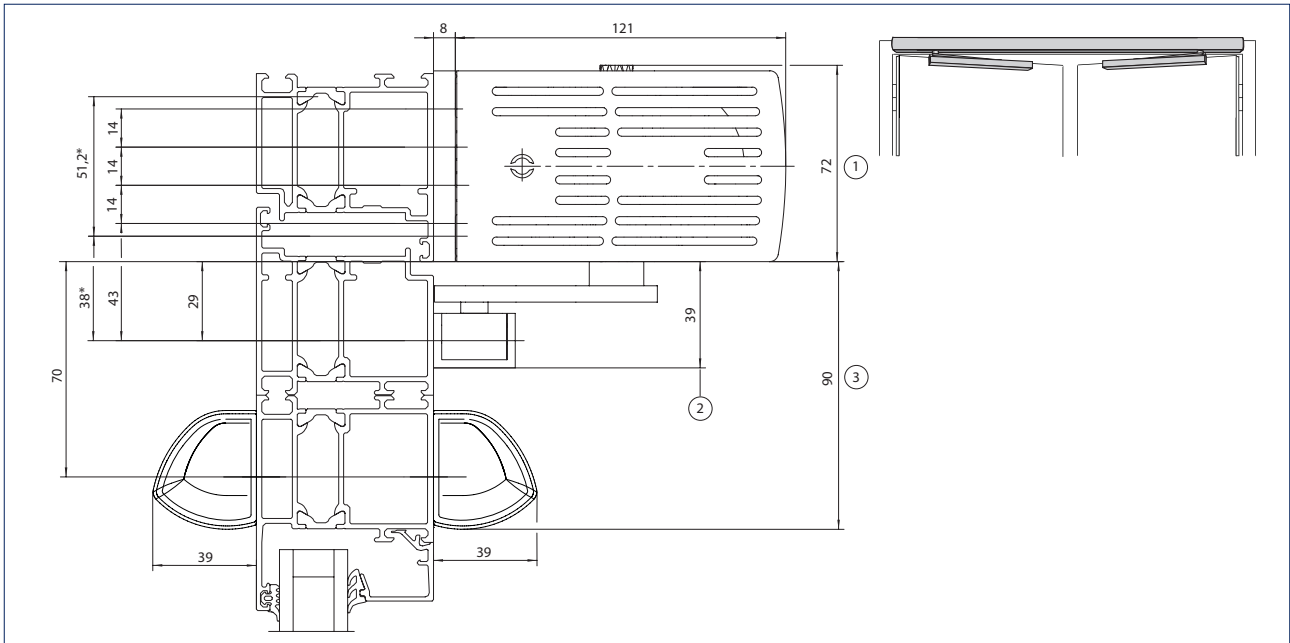

- * = Direct installation
- 1 = Space requirement for EMD-F/EMD Invers
- 2 = Space requirement for roller guide rail
- 3 = Space requirement for sensor strips

Installation with mounting plate (A) and direct installation (B)

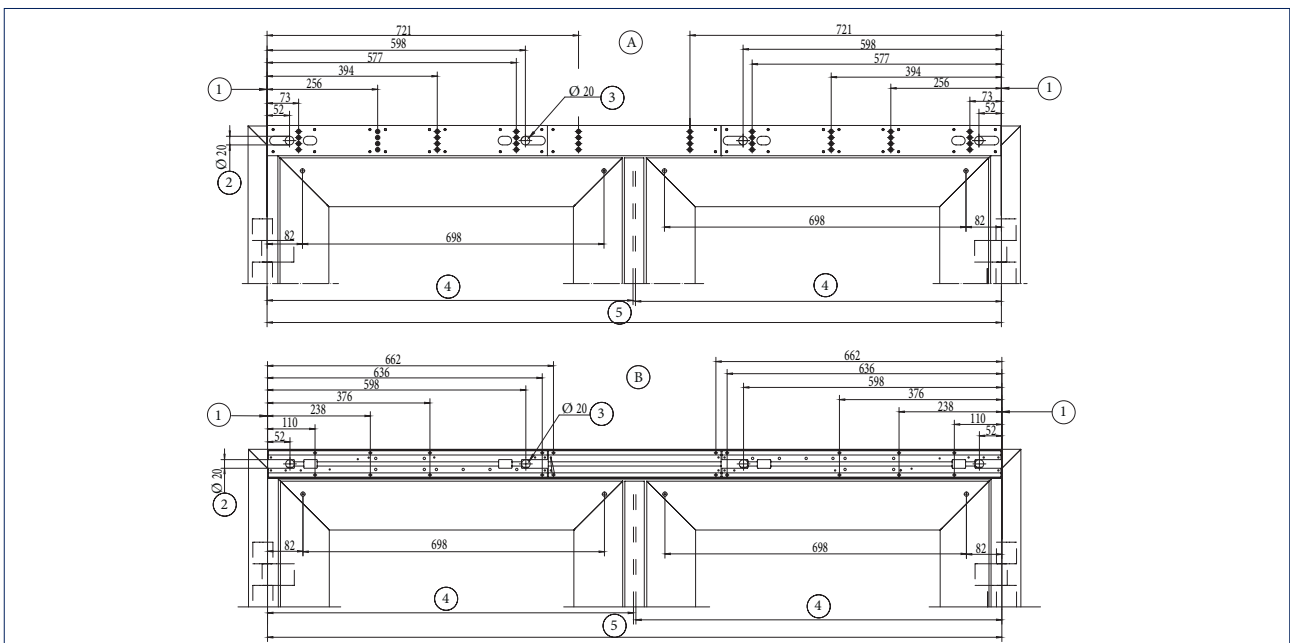

- A = Installation with mounting plate
- B = Direct installation
- 1 = Dimensional reference centre of hinge
- 2 = Concealed cable routing for sensors, door opener, programme switch and lock switch contact
- 3 = Concealed cable routing 230 V / 50 Hz
- 4 = Door leaf width
- 5 = Hinge clearance

GEZE SLIMDRIVE EMD

Transom installation with link arm on the opposite hinge side, double-leaf

Drawing no. 70106-ep23

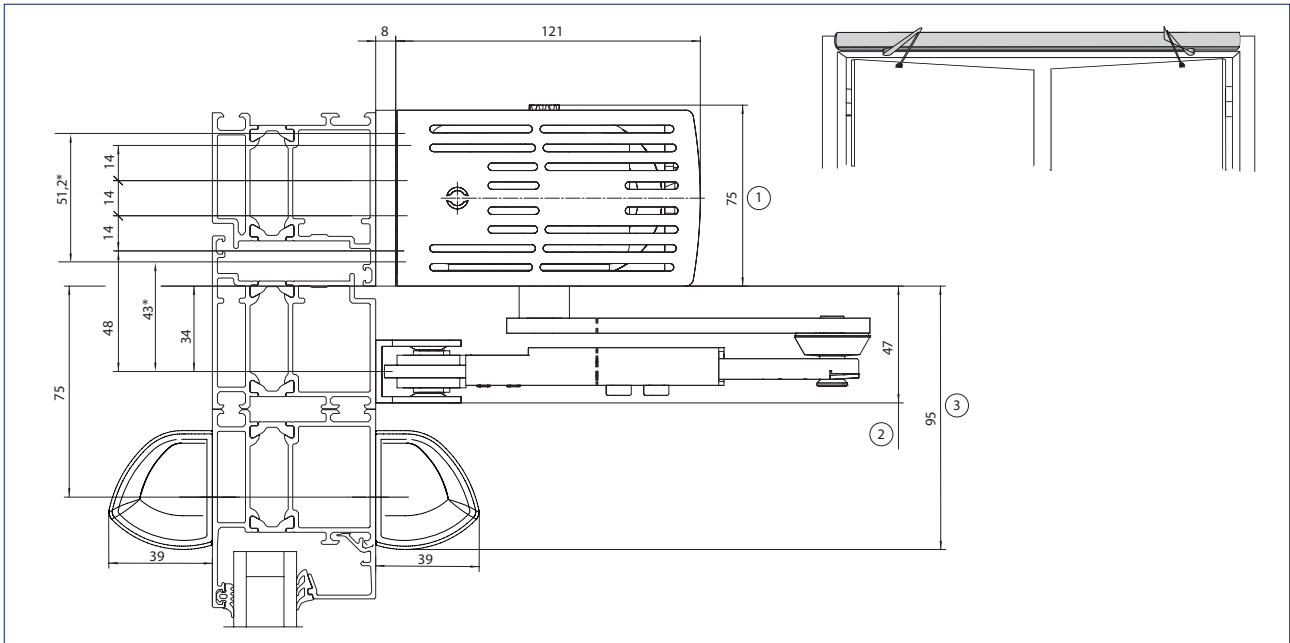

- * = Direct installation
- 1 = Space requirement for EMD-F/EMD Invers
- 2 = Space requirement for link arm
- 3 = Space requirement for sensor strips

Installation with mounting plate (A) and direct installation (B)

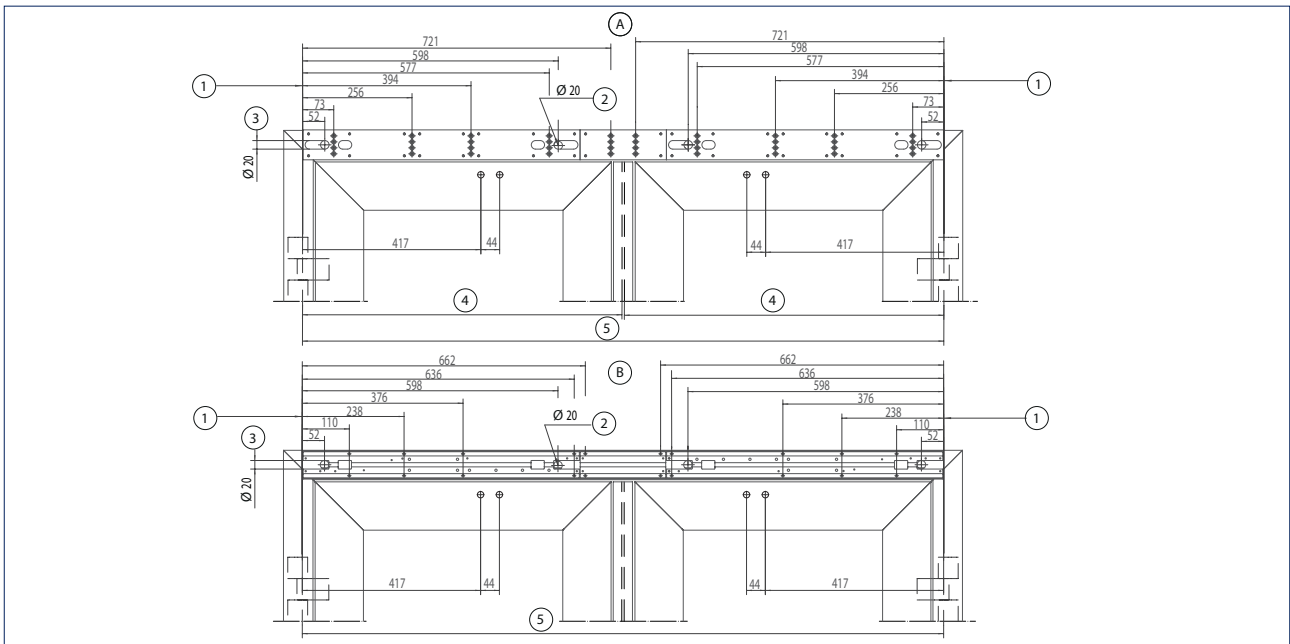

- A = Installation with mounting plate
- B = Direct installation
- 1 = Dimensional reference centre of hinge
- 2 = Concealed cable routing for sensors, door opener, programme switch and lock switch contact
- 3 = Concealed cable routing 230 V / 50 Hz
- 4 = Door leaf width
- 5 = Hinge clearance

Legend for the cable diagrams

Cable

- 1 = NYM-J 3 x 1.5 mm²
- 2 = J-Y(ST)Y 1 x 2 x 0.6 LG
- 3 = J-Y(ST)Y 2 x 2 x 0.6 LG
- 4 = J-Y(ST)Y 4 x 2 x 0.6 LG
- 5 = LiYY 2 x 0.25 mm²
- 6 = LiYY 4 x 0.25 mm²
- 7 = Scope of supply sensor strip or LiYY 5 x 0.25 mm²
- 8 = Route empty pipe with pull-wire inner diameter 10 mm

Notes

- Cable diagrams can also be prepared for specific building projects after receipt of order
- Version of standard cable diagrams in accordance with GEZE specifications
- Cable routing according to VDE0100/ IEE regulations
- Allow the cable for the drive to project at least 1500 mm out of the wall

1) Door transmission cable (including in the scope of supply for sensor strip), cable routing through a hole in the door leaf is not permitted for fire protection doors.

2) Cable exit for door drive, see installation drawings for Slimdrive EMD/EMD-F 70106-ep01 to -ep04

3) Cable including in the scope of supply for the sensor

4) Install in the direct vicinity of the door

5) Mains connection box WxHxD min. 65 x 65 x 57 with PG-11 duct, on site

6) Low-voltage connection box WxHxD min. 94 x 65 x 57 with PG-11 duct, on site

7) E.g. door transmission cable, 8-wire, art. no. 066922

8) Branch box, on site

Abbreviations

HS	= Main switch
NOT	= Emergency-stop switch
UT	= Circuit breaker CLOSE DOOR (only with F variant)
KB	= Contact sensor authorised
PS	= Programme switch
ST	= Emergency stop
KI	= Contact sensor inside
KA	= Contact sensor outside
TOE	= Door opener
RM	= Bar message
RS	= Smoke switch (only with F variant)
RSZ	= Smoke switch control unit (only with F variant)
TS	= Door closer
MK	= Magnetic contact

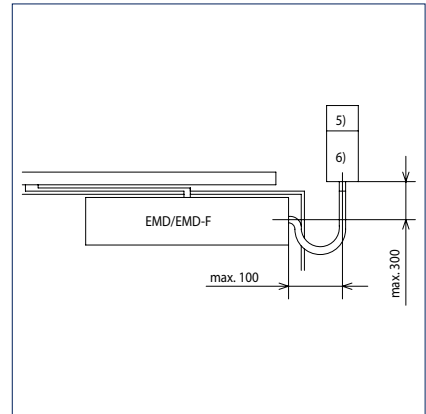
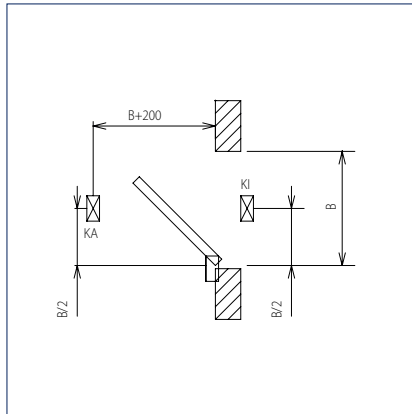
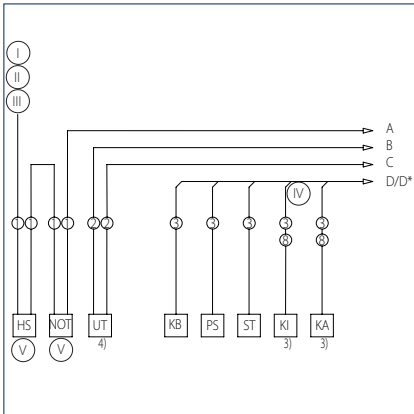

- I = Feeder 230 V / 50 Hz
- II = 10 A fuse
- III = Connected value 230 W, 1 A 1-, 2-leaf with manual fixed leaf; connected value 460 W, 1 A with 2-leaf
- IV = And / Or
- V = Option

1-leaf

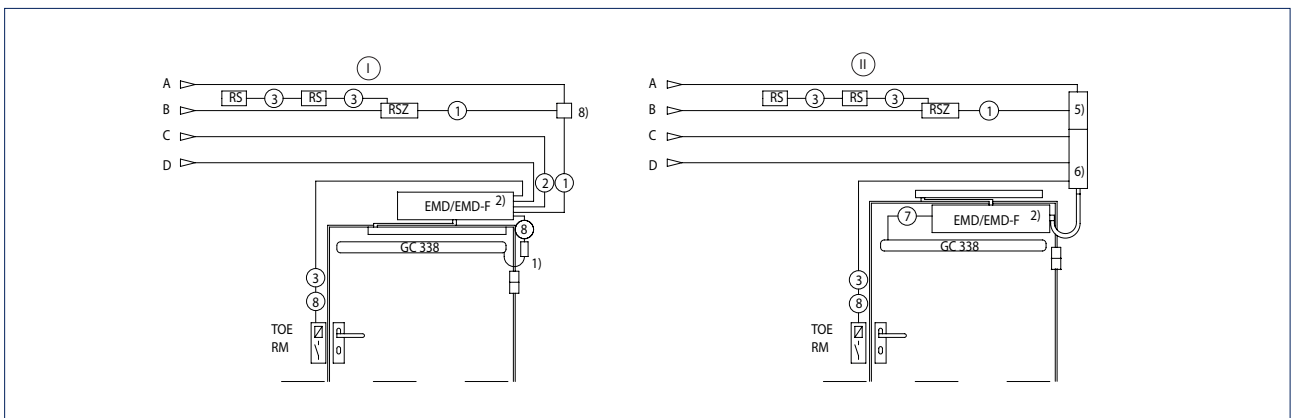

2-leaf

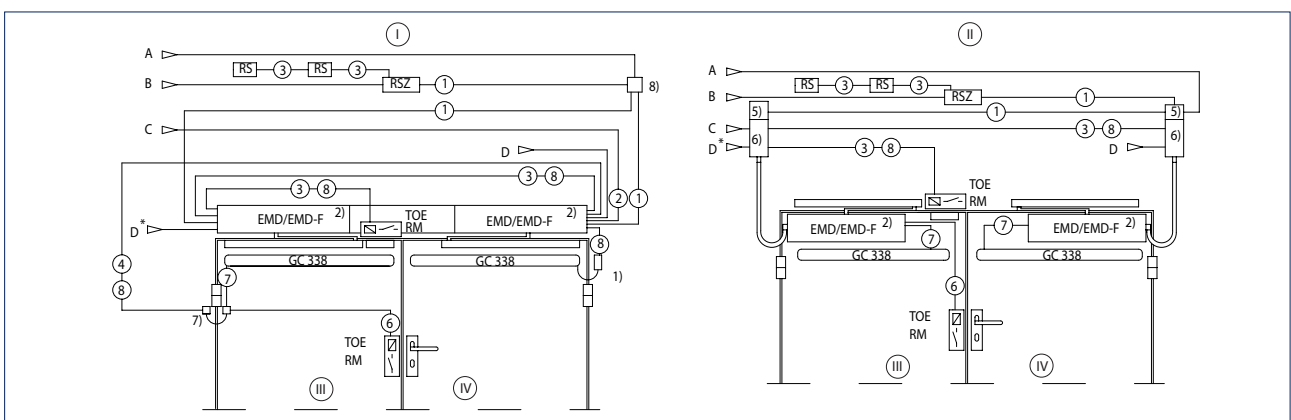

- I = Transom installation
- II = Door leaf installation
- III = Fixed leaf
- IV = Active leaf

GEZE swing door drive TSA 160 NT

Electrohydraulic swing door drive for 1 and 2-leaf single-action doors

The TSA 160 NT is an electronically controlled hydraulic swing door system for single-action doors made of wood, steel, aluminium or plastic with leaf weights of up to 310 kg and leaf widths of up to 1600 mm. The drive works with a hydraulic pump system during opening. The closing process is by means of a closing spring mechanism and adjustable hydraulic valves. The TSA 160 NT also has low power consumption and is low-maintenance. The door can be opened by hand in the event of a power failure. Manual opening is also possible with motor operation switched on. A reinforced and highly stable link arm meets the requirements of large and heavy doors which are highly frequented. The TSA 160 NT masters large amounts of foot traffic reliably and easily.



GEZE TSA 160 NT

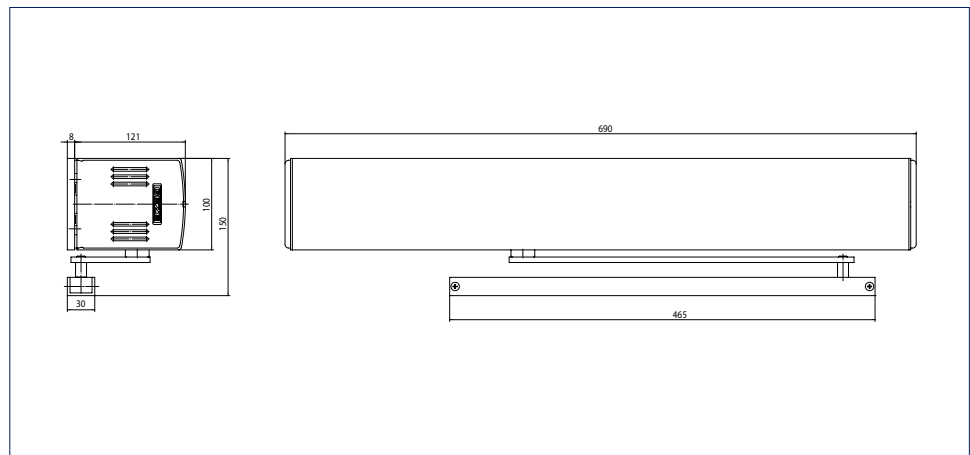

Application range

- Internal and external doors
- Railway stations and airports
- Hotels and gastronomy
- Hospitals and nursing homes for the elderly
- Department stores and shopping centre
- Educational institutions e.g. schools, nursery schools, day care centres
- Leisure facilities, e.g. baths, thermal baths, sport and wellness centres
- Administration and public buildings
- Food industry

Technical data

Product features	GEZE TSA 160 NT	GEZE TSA 160 NT Invers	GEZE TSA 160 NT IS	GEZE TSA 160 NT EN7	GEZE TSA 160 NT IS EN7
Height			100 mm		
Width			690 mm		
Depth			121 mm		
Leaf weight (max.) 1-leaf	250 kg		310 kg		
Hinge clearance (min.-max.) 2-leaf	1470 – 2800 mm		1470 – 3200 mm		
Leaf width (min.-max.)	690 – 1400 mm		690 – 1600 mm		
Reveal depth (max.)*			400 mm		
Door overlap (max.)*			20 mm		
Drive type			Electrohydraulic		
Door opening angle (max.)*			115 °		
Spring pre-load**	EN3 – EN6		EN7		
Z-variant (pulling)	•	-	•	•	•
Z-variant (pushing)	-	•	-	-	-
DIN left	•	•	•	•	•
DIN right	•	•	•	•	•
Transom installation opposite hinge side with link arm	•	•	•	•	•
Transom installation hinge side with roller guide rail	•	•	•	•	•
Mechanical latching action	•	-	•	•	•
Electrical closing sequence control	•	•	•	•	•
Mechanical closing sequence control	-	-	•	-	•
Disconnection from mains			Not available		
Activation delay (max.)			10 S		
Operating voltage			230 V		
Frequency of supply voltage			50 – 60 Hz		
Capacity rating	300 W		450 W		
Power supply for external consumers (24 V DC)			1200 mA		
Temperature range***			-15 – 60 °C		
IP rating			IP 20		
Operating modes			Off, Automatic, Permanently open, Shop closing, Night		
Type of function			Fully automatic		
Automatic function	•	•	•	•	•
Key function	•	•	•	•	•
Inverse function (opening by spring force)	-	•	-	-	-
Vestibule function	•	•	•	•	•
Obstruction detection	•	•	•	•	•
Automatic reversing	•	•	•	•	•
Push & Go			adjustable		
Operation			Display programme switch DPS		
Parameter setting			Display programme switch DPS		
Approvals			DIN 18650, EN 16005		
Use on fire and smoke protection doors (F-variant)	•	-	•	•	•

• = Yes

* = Depending on the type of installation

** = See table overview of torques

*** = The door drive is intended for use in dry rooms only

NOTE: THE MAXIMUM POSSIBLE LEAF WEIGHT IN RELATION TO LEAF WIDTH CAN BE FOUND IN THE CHAPTER ON AREAS OF APPLICATION (DIAGRAMS)!

Overview of torques TSA 160 NT

	pushing (min.-max.)	pulling (min.-max.)
Spring pre-load Closer size EN 1154	3 - 6 7 (with TSA 160 NT EN7)	2 - 5 6 (with TSA 160 NT EN7)
Closer torques: torque exerted by the closing spring during automatic opening	20 Nm - >60 Nm	8 Nm - 30 Nm
Opening torque: torque exerted by the door during automatic opening	150 Nm - 90 Nm	70 Nm - 40 Nm
Opening torque: manual torque to be exerted for door opening	35 Nm - 110 Nm	13 Nm - 45 Nm

Note: For automatic mode, the doors must be equipped with suitable hinges. A door stop is necessary.

TSA 160 NT minimum and maximum leaf widths

1-leaf doors	Leaf width (min.)	Leaf width (max.)
TSA 160 NT pushing ¹⁾	690 mm	1400 mm / 1600 mm ²⁾
TSA 160 NT pulling	950 mm (with operator displacement=0) 890 mm (with operator displacement=60 mm)	1400 mm / 1600 mm ²⁾
TSA 160 NT Z	690 mm	1400 mm / 1600 mm ²⁾

¹⁾ Also on smoke and fire protection doors

²⁾ TSA 160 NT EN7

TSA 160 NT minimum and maximum leaf widths, hinge clearance for 2-leaf doors

2-leaf doors	Hinge clearance (min.)	Hinge clearance (max.)	Leaf width (min.) active leaf²⁾	Leaf width (min.) fixed leaf²⁾	Leaf width (max.)
TSA 160 NT IS pushing ¹⁾	1470 mm	2800 mm / 3200 mm ³⁾	690 mm	400 mm	1400 mm / 1600 mm ²⁾
TSA 160 NT Z-IS pulling	1470 mm	2800 mm / 3200 mm ³⁾	690 mm	650 mm	1400 mm / 1600 mm ²⁾
TSA 160 NT IS/TS pushing ¹⁾	1260 mm	2800 mm / 3200 mm ³⁾	690 mm	400 mm	1400 mm / 1600 mm ²⁾
TSA 160 NT IS/TS pulling	1360 mm	2800 mm / 3200 mm ³⁾	690 mm	650 mm	1400 mm / 1600 mm ²⁾

¹⁾ Also on smoke and fire protection doors

²⁾ The minimum hinge width must be observed!

³⁾ TSA 160 NT IS EN7

Areas of application

TSA 160 NT

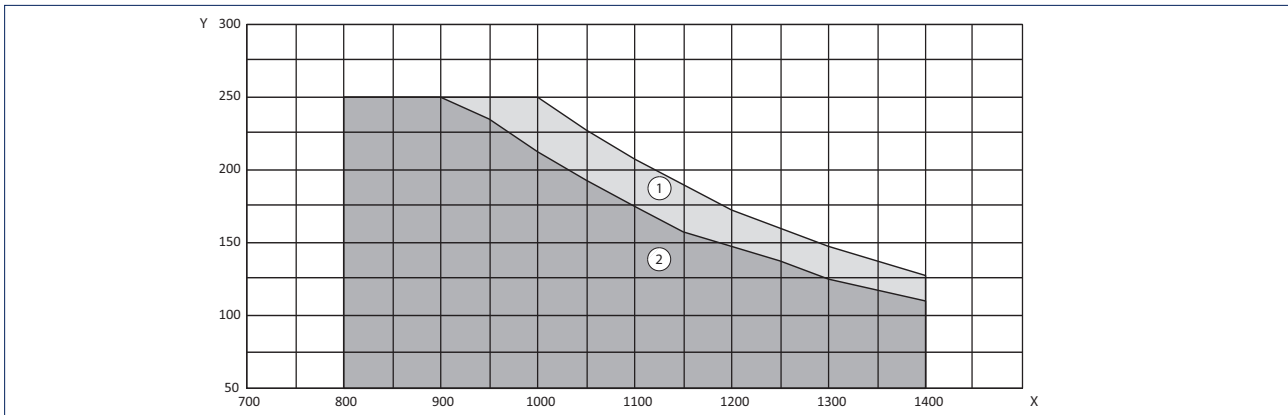

X = Door width (mm)

Y = Door weight (kg)

1 = Link arm

2 = Roller guide rail

TSA 160 NT EN7

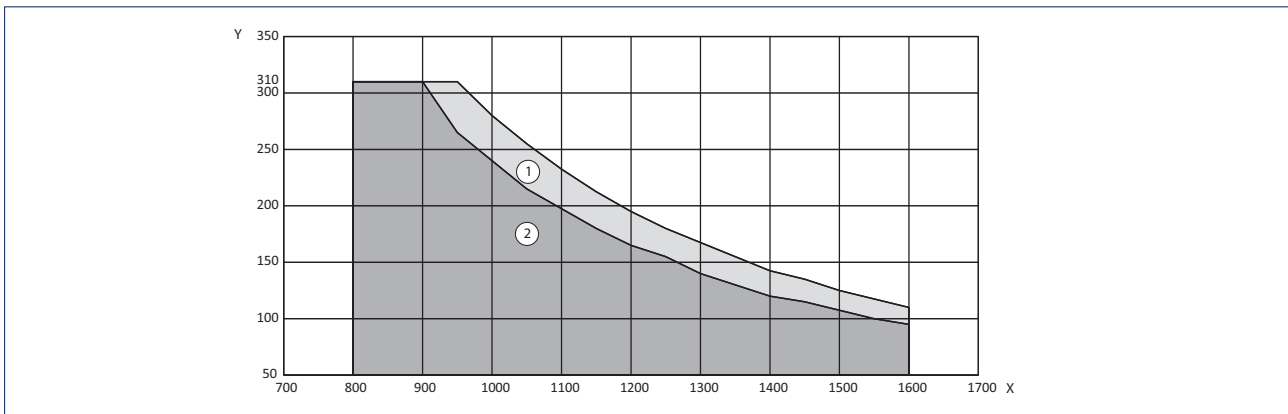

X = Door width (mm)

Y = Door weight (kg)

1 = Link arm

2 = Roller guide rail

GEZE TSA 160 NT

Note: Diagram shows left-hand (ISO 6), right-hand (ISO 5) is reversed (mirror-image).

Transom installation with roller guide rail on the hinge side, single-leaf

Drawing no. 70423-ep02

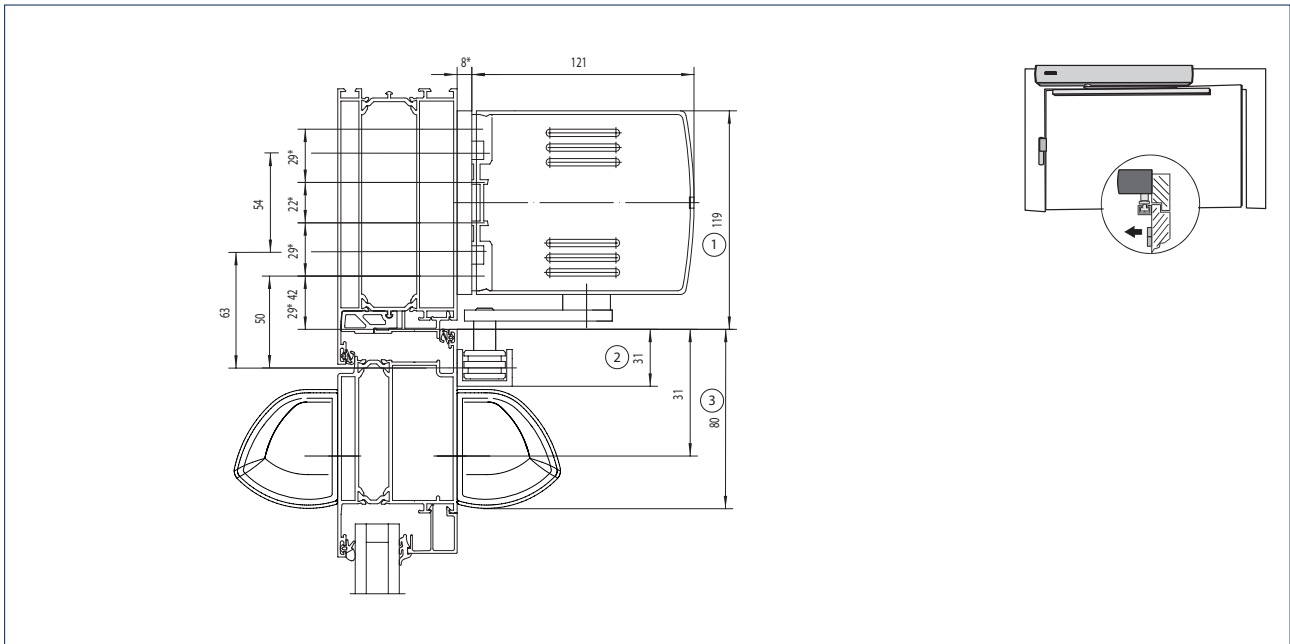

- * = Installation with mounting plate
- 1 = Space requirement for TSA 160 NT
- 2 = Space requirement for roller guide rail
- 3 = Space requirement for sensor strips

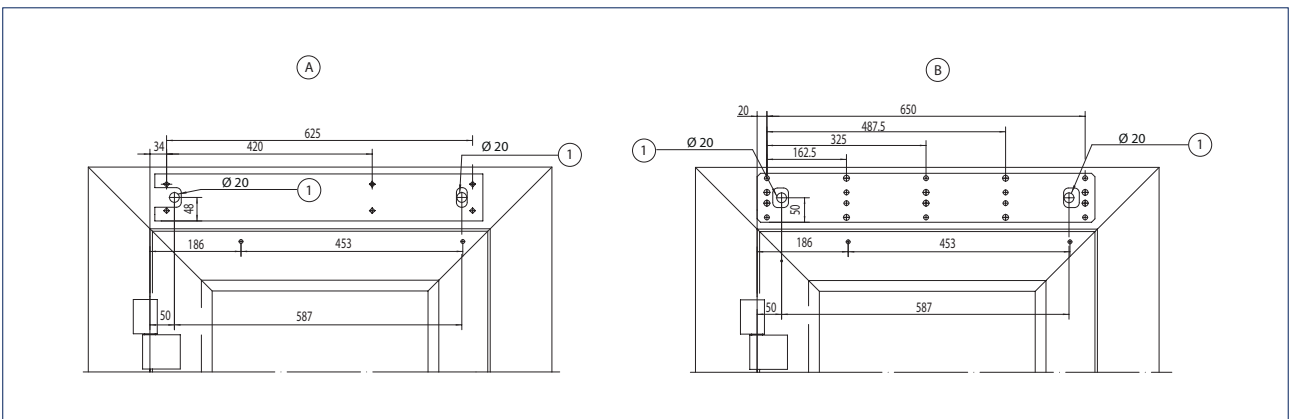

- A = Direct installation
- B = Installation with mounting plate
- 1 = Concealed cable routing

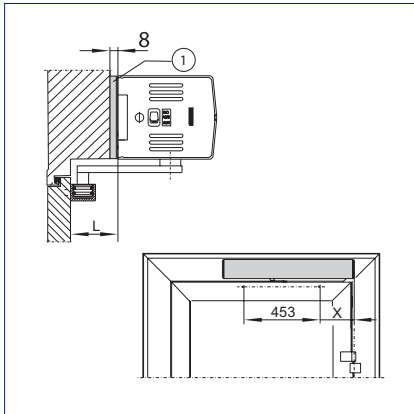

1 = Mounting plate

TSA 160 NT

Soffit depth L (from-to)	Dimension X for roller guide rail with TSA 160 NT Z	Door width (min.)	Opening angle
> 0 - 25 mm	186 mm	690 mm	109° - 113°
> 25 - 50 mm	192 mm	690 mm	113° - 115°
> 50 - 75 mm	203 mm	690 mm	115° - 110°
> 75 - 100 mm	215 mm	690 mm	110° - 105°
> 100 - 125 mm	229 mm	690 mm	105° - 100°
> 125 - 150 mm	244 mm	703 mm	100° - 97°
> 150 - 175 mm	262 mm	721 mm	97° - 95°
> 175 - 200 mm	280 mm	739 mm	95° - 90°

Transom installation with roller guide rail on the hinge side, double-leaf

Drawing no. 70423-ep22

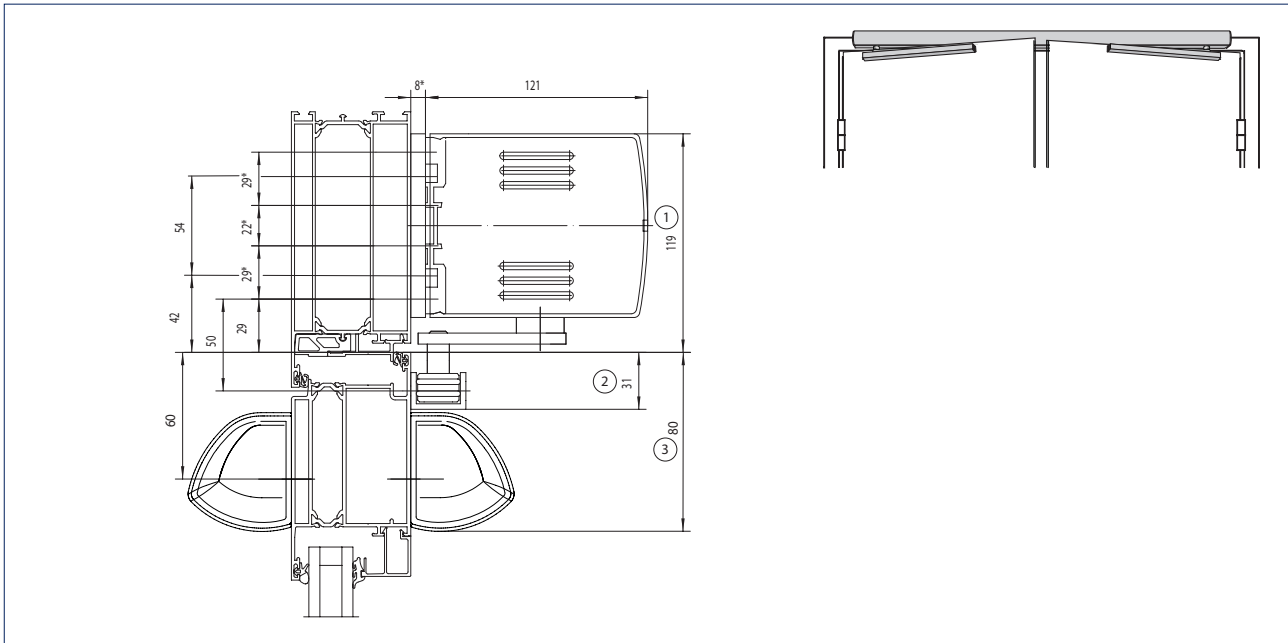

- * = Installation with mounting plate
- 1 = Space requirement for TSA 160 NT
- 2 = Space requirement for roller guide rail
- 3 = Space requirement for sensor strips

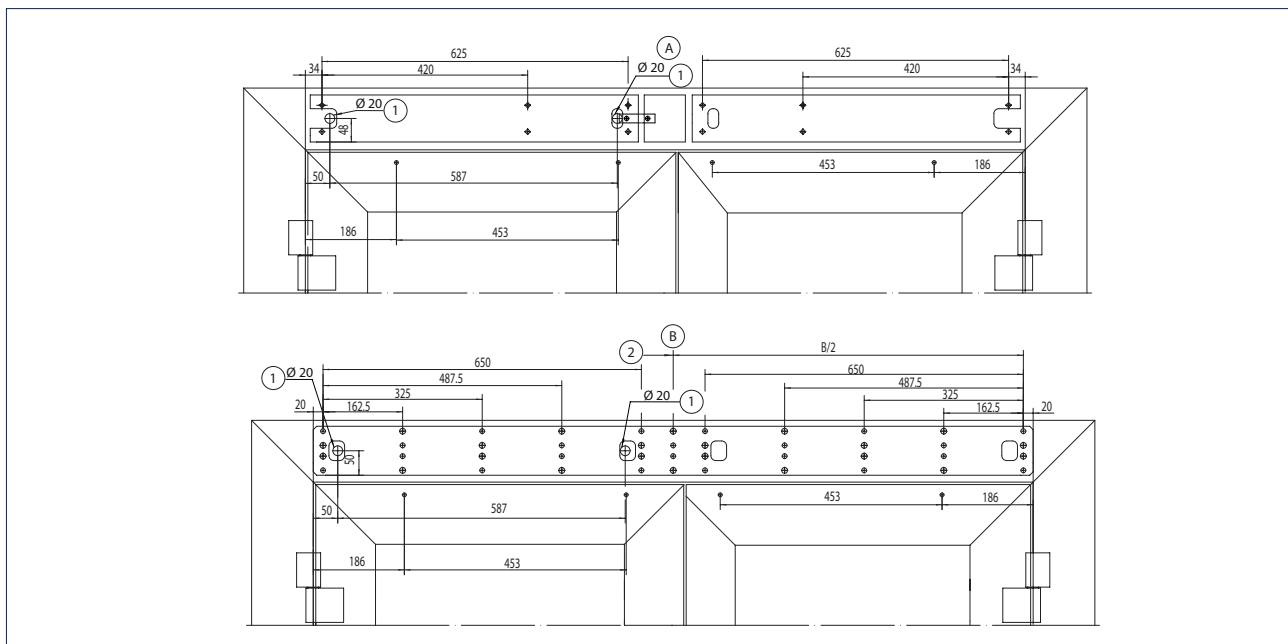

- A = Direct installation
- B = Installation with mounting plate
- 1 = Concealed cable routing
- 2 = only required for B > 2000

Transom installation with link arm on the opposite hinge side, double-leaf

Drawing no. 70423-ep11

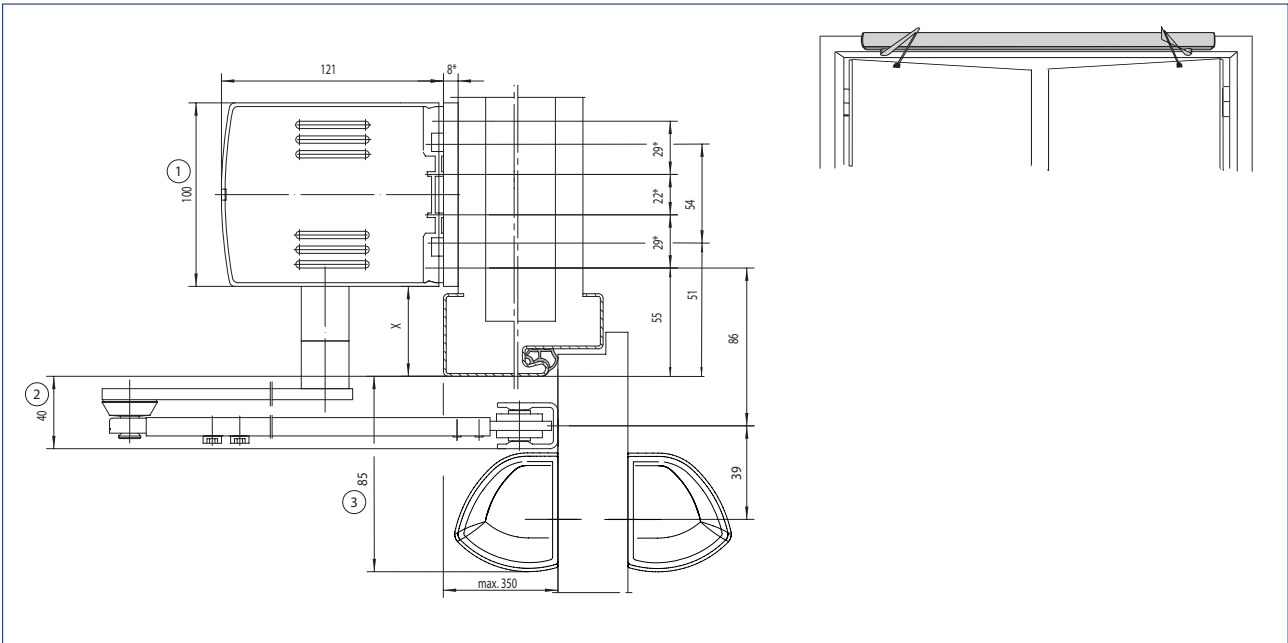

- X = Spindle extension
- * = Installation with mounting plate
- 1 = Space requirement for TSA 160 NT
- 2 = Space requirement for link arm
- 3 = Space requirement for sensor strips

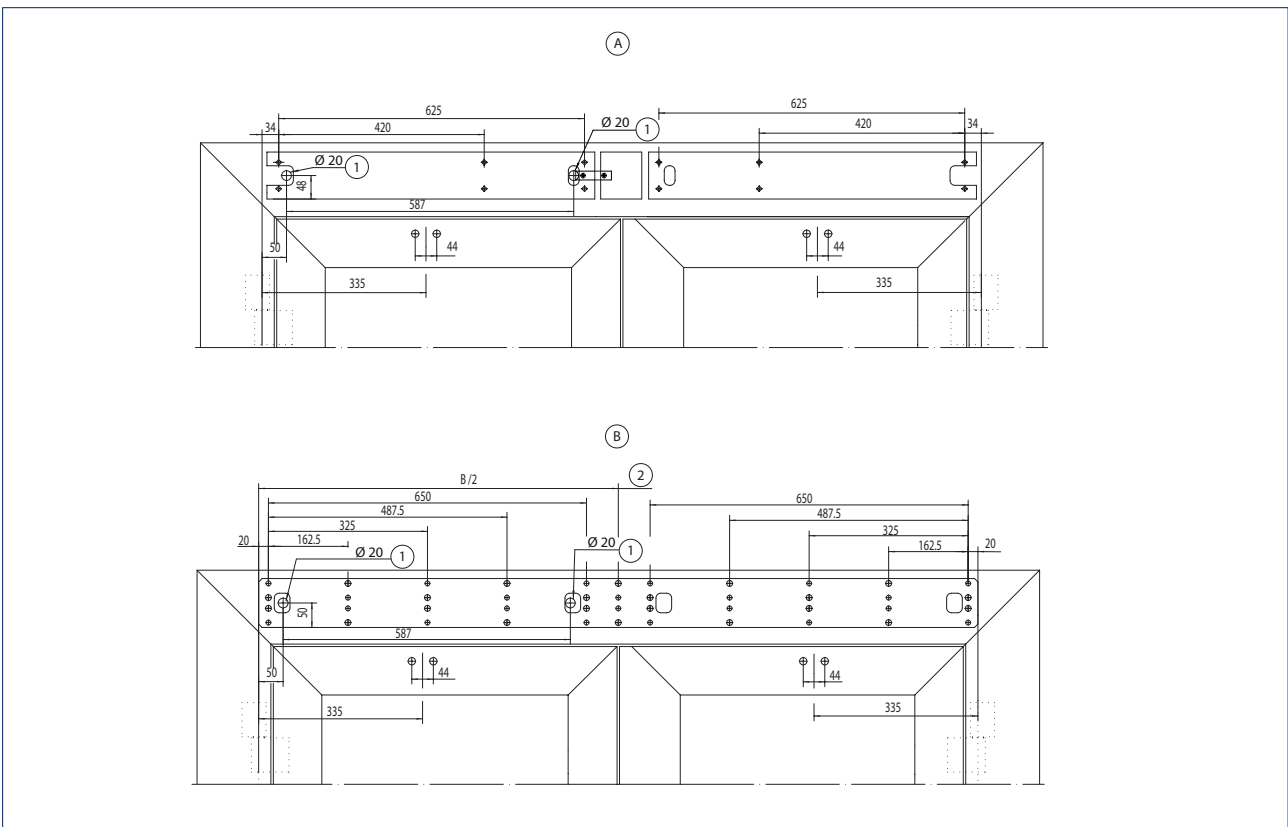

- A = Direct installation
- B = Installation with mounting plate
- 1 = Concealed cable routing
- 2 = only required for B > 2000

Legend for the cable diagrams

Cable

- 1 = NYM-J 3 x 1.5 mm²
- 2 = J-Y(ST)Y 1 x 2 x 0.6 LG
- 3 = J-Y(ST)Y 2 x 2 x 0.6 LG
- 4 = J-Y(ST)Y 4 x 2 x 0.6 LG
- 5 = LiYY 2 x 0.25 mm²
- 6 = LiYY 4 x 0.25 mm²
- 7 = Scope of supply sensor strip or LiYY 5 x 0.25 mm²
- 8 = Route empty pipe with pull-wire inner diameter 10 mm

Operator displacement

- AV = Cable exit
- 60 mm = 580 mm
- 50 mm = 590 mm
- 40 mm = 600 mm (standard)
- 30 mm = 610 mm
- 20 mm = 620 mm
- 10 mm = 630 mm
- 0 mm = 640 mm

Notes

- Cable diagrams can also be prepared for specific building projects after receipt of order
- Version of standard cable diagrams in accordance with GEZE specifications
- Cable routing according to VDE0100/ IEE regulations
- Allow the cable for the drive to project at least 1500 mm out of the wall

1) Door transmission cable (including in the scope of supply for sensor strip), cable routing through a hole in the door leaf is not permitted for fire control doors.

2) Cable exit for door drive see sketch A and B

3) Cable including in the scope of supply for the sensor

4) Install in the direct vicinity of the door

7) E.g. door transmission cable, 8-wire, art. no. 066922

8) Branch box, on site

Abbreviations

- HS = Main switch
- NOT = Emergency-stop switch
- UT = Circuit breaker CLOSE DOOR (only with F variant)
- KB = Contact sensor authorised
- PS = Programme switch
- ST = Emergency stop
- KI = Contact sensor inside
- KA = Contact sensor outside
- TOE = Door opener
- RM = Bar message
- RS = Smoke switch (only with F variant)
- RSZ = Smoke switch control unit (only with F variant)
- TS = Door closer
- MK = Magnetic contact

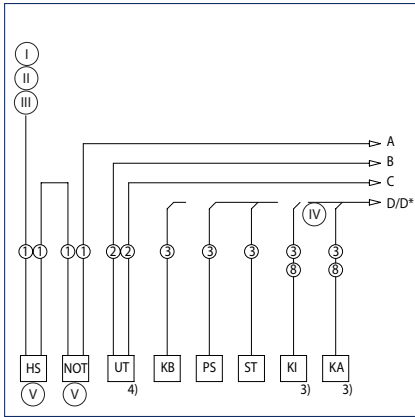

I = Feeder 230 V / 50 Hz

II = 10 A fuse

III = Connected value 300 W 1.3 A for 1- 2-leaf with manual fixed leaf Connected value 600 W 2.6 A for 2-leaf

IV = And / Or

V = Option

Positioning of the movement detectors

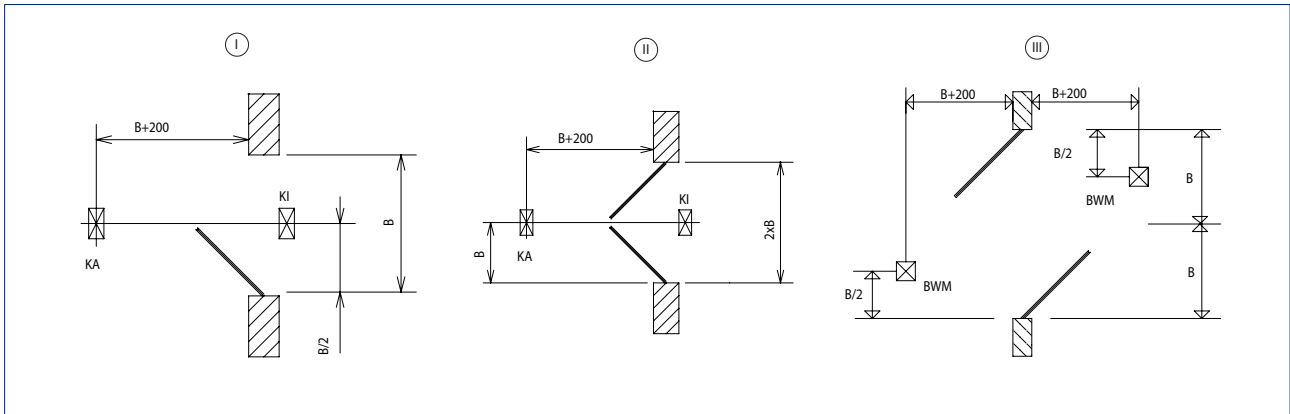

I = Positioning of movement detector 1-leaf

II = Positioning of movement detector 2-leaf

III = Positioning of movement detector 2-leaf, 2E

TSA 160 NT cable plan single-leaf

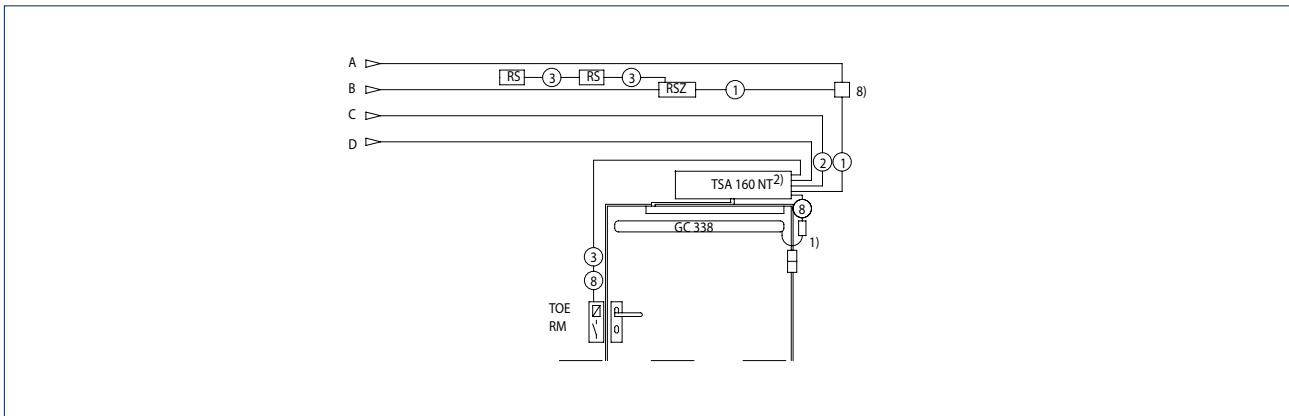

TSA 160 NT cable plan double-leaf

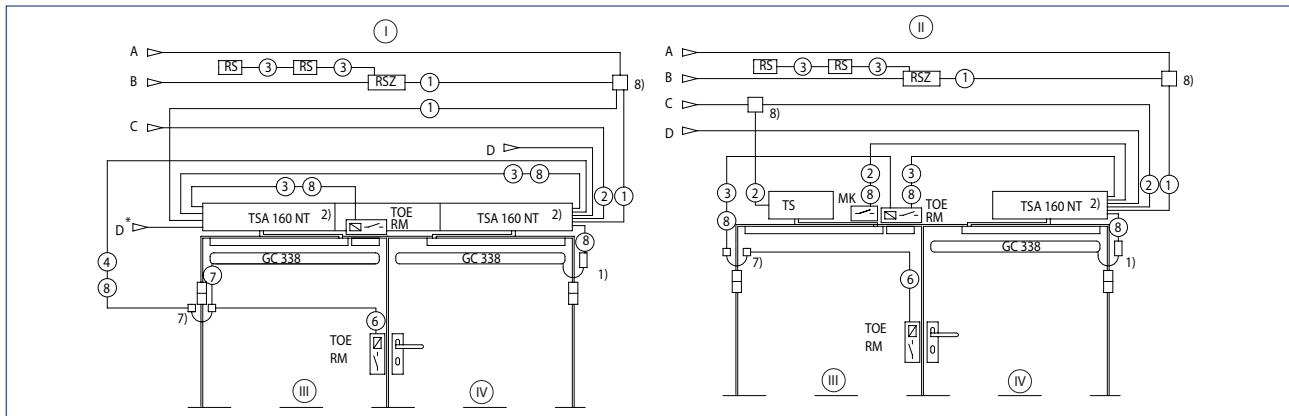

- I = 2-leaf
- II = 2-leaf with manual fixed leaf
- III = Fixed leaf
- IV = Active leaf

TSA 160 NT cable exit

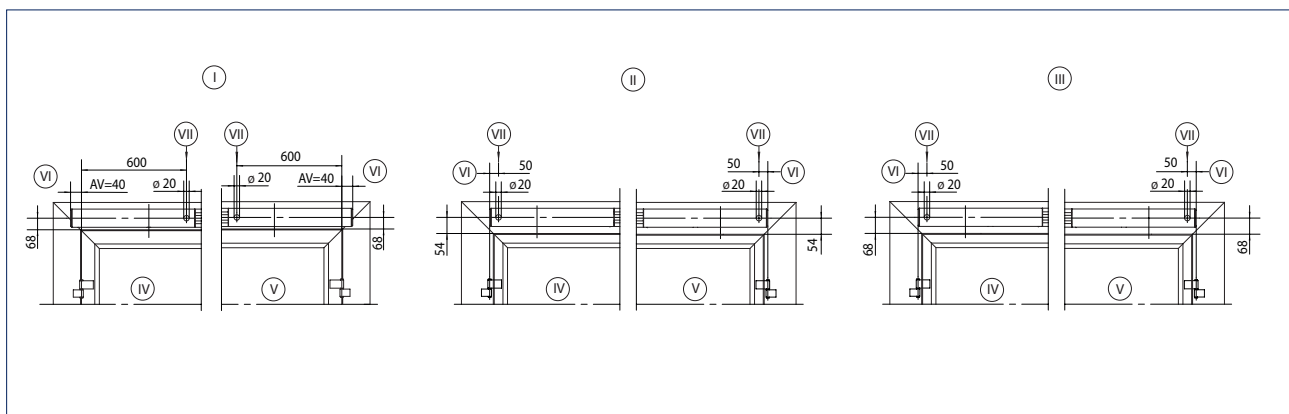

- AV = Operator displacement
- I = TSA 160 NT installation hinge side
- II = TSA 160 NT installation opposite hinge side
- III = TSA 160 NT-Z installation hinge side
- IV = Drive left - pulling
- V = Drive right - pulling
- VI = from top of leaf, dimension for spindle extensions must be added
- VII = Cable exit

GEZE swing door drive Powerturn

Fully automatic swing door drive for 1 and 2-leaf single-action doors

The swing door drive Powerturn offers comfort and safety for every access situation. The fully automatic drive is powerful and opens even large, heavy doors with leaf weights up to 600 kg at door widths of 930 mm reliably and safely. GEZE's powerful model is also the perfect solution for fire protection doors with leaf weights up to 600 kg. It offers freedom to design for a wide range of uses. The unique „Smart swing“ function allows for easy manual use even of large, heavy doors, e.g. fire protection doors or façade doors, at any time. The powerful closing spring is once pre-tensioned and does not have to be moved permanently during passage. In addition, the „Smart swing“ function reduces energy costs during operation and in the „permanently open“ position. The small overall height and discreet design make it flexible and future-proof for multifunction safety doors, safe escape and rescue routes and complex interlocking door systems. This makes the Powerturn an excellent example of „Universal Design - made in Germany“. Installation is straightforward and safe due to the simple GEZE installation system.



GEZE Powerturn

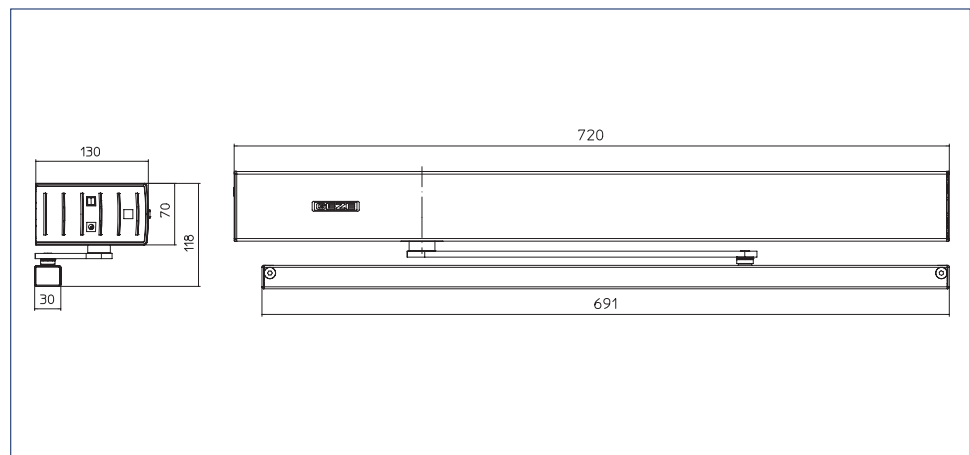

Area of application

- Internal and external doors
- Railway stations and airports
- Hotels and gastronomy
- Hospitals and homes for the elderly
- Department stores and shopping centres
- Educational institutions, e.g. schools, nursery schools, day care centres
- Leisure facilities, e.g. baths, thermal baths, sport and wellness centres
- Administration and public buildings
- Food industry

Technical data

Product features	GEZE Powerturn 1-leaf / 2-leaf	GEZE Powerturn F	GEZE Powerturn F-IS	GEZE Powerturn F/R	GEZE Powerturn F/R-IS	GEZE Powerturn IS/TS
Height	70 mm					
Width	720 mm					-
Depth	130 mm					
Leaf weight (max.) 1-leaf	600 kg with door widths of 930 mm					
Hinge clearance (min.-max.) 2-leaf link arm	1480 – 3200 mm					1270 – 3200 mm
Hinge clearance (min.-max.) 2-leaf roller guide rail	1600 – 3200 mm					1380 – 3000 mm
Leaf width (min.-max.)	800 – 1600 mm					470 – 1600 mm
Reveal depth (max.)*	-30 – 560 mm	-30 – 300 mm				160 mm
Drive type	Electromechanical					
Door opening angle (max.)*	136 °					
Spring pre-load**	EN4 – EN7					EN1 - EN7
DIN left	•					-
DIN right	•					-
Transom installation opposite hinge side with link arm	•					
Transom installation opposite hinge side with roller guide rail	•					-
Transom installation hinge side with roller guide rail	•					
Door leaf installation opposite hinge side with roller guide rail	•					-
Door leaf installation hinge side with roller guide rail	•					-
Door leaf installation hinge side with link arm	•					-
Mechanical latching action	•					
Electrical latching action	•					-
Electrical closing sequence control	•					-
Mechanical closing sequence control***	•					
Disconnection from mains	all pole main switch in the drive					
Activation delay (max.)	10 s					
Operating voltage	230 V					
Frequency of supply voltage	50 – 60 Hz					
Capacity rating	200 W					
Power supply for external consumers (24 V DC)	1200 mA per drive					
Temperature range****	-15 – 50 °C					
IP rating	IP 30					
Operating modes	Automatic, Night, Permanently open, Shop closing, Off					
Type of function	Fully automatic					
Automatic function	•					
Low-Energy function	•					
Smart swing function	•					
Key function	•					
Vestibule function	•					
Obstruction detection	•					
Automatic reversing	•					
Push & Go	adjustable					
Operation	GEZEconnects (PC + Bluetooth), Service terminal ST 220, Display programme switch DPS					
Parameter setting	GEZEconnects (PC + Bluetooth), Service terminal ST 220, Display programme switch DPS					
Approvals	DIN 18650, EN 16005, DIN 18263-4	DIN 18650, EN 16005, DIN 18263-4	DIN 18650, EN 16005, DIN 18263-4, Door closing sequence selector tested in accordance with EN 1158	DIN 18650, EN 16005, DIN 18263-4	DIN 18650, EN 16005, Door closing sequence selector tested in accordance with EN 1158	
Integrated smoke switch (R-variant)	-					•

• = Yes

* = Depending on the type of installation

** = See table overview of torques

*** = Optional for 2-leaf Systems and transom installation or only for the is variants

**** = The door drive is intended for use in dry rooms only

NOTE: THE MAXIMUM POSSIBLE LEAF WEIGHT IN RELATION TO LEAF WIDTH CAN BE FOUND IN THE CHAPTER ON AREAS OF APPLICATION (DIAGRAMS)!

Technical data for use of the IS/TS variant**GEZE Powerturn IS/TS with TS 5000 L door closer**

Element	Active leaf	Passive leaf
Drive/door closer	GEZE Powerturn (F) (F/R)	TS 5000 L
Lever type	Roller guide rail	Guide rail
Min. - max. leaf width	800 - 1600 mm	580 - 1400 mm
Min. - max. hinge size	1380 - 3000 mm	
Reveal	0 mm	
EN closing force	EN 4-6	EN 2-6

GEZE Powerturn IS/TS with TS 4000 door closer

Element	Active leaf	Passive leaf
Drive/door closer	GEZE Powerturn (F) (F/R)	TS 4000 EN 1-6 or EN 5-7
Lever type	Link arm	Link arm
Min. - max. leaf width	800 - 1600 mm	470 - 1600 mm
Min. - max. hinge size	1270 - 3200 mm	
Reveal	160 mm	
EN closing force	EN 6-7	EN 1-7*

* Standard package with TS 4000 EN 1-6, on request via Customer Solutions there is the option for the use of the GEZE TS 4000 EN 5-7

Area of application

Note

The movement parameters can be set in such a way that the safety requirements for low-energy operation in compliance with DIN 18650 / EN 16005 are met. The drive then moves the swing door at reduced speed. The use of safety sensors to safeguard the system is only necessary in individual cases, taking the user group into account. In automatic mode, however, the swing area of the door must always be safeguarded with safety sensors.

Diagram showing the use of Powerturn with opening times of up to 90° door opening angle

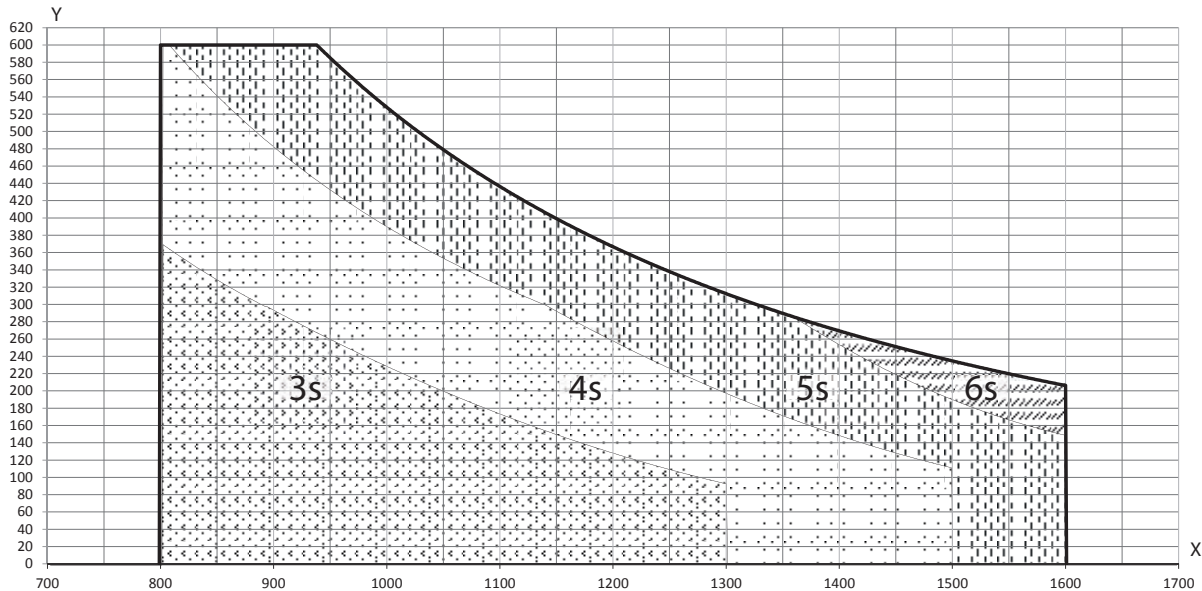

X = Door width (mm)
 Y = Door weight (kg)

Opening times Powerturn

To ensure the safety requirements in low-energy operation

	Door weight (kg)																			
	60	90	120	150	180	210	240	270	300	330	370	400	430	460	490	520	550	580	600	
Leaf width (mm)	800	4	4	5	5	6	6	7	7	7	8	8	8	9	9	9	10	10	10	10
	900	4	5	5	6	7	7	7	8	8	9	9	9	10	10	11	11	11	11	11
	1000	4	5	6	7	7	8	8	9	9	10	10	10	11	11	12	12	12	12	13
	1100	5	6	6	7	8	8	9	9	10	10	11	11	12	12	13	13	13	14	14
	1200	5	6	7	8	8	8	10	10	11	11	12	12	13	13	14	14	15	15	15
	1300	6	7	8	8	9	10	11	11	12	12	13	13	14	14	15	15	16	16	16
	1400	6	7	8	9	10	11	11	12	13	13	14	14	15	15	16	16	17	17	18
	1500	6	8	9	10	11	11	12	13	13	14	15	15	16	17	17	18	18	18	19
1600	7	8	9	10	11	12	13	14	14	15	16	16	17	18	18	19	19	20	20	

Illustration of the minimum opening times to be set depending on the door weight and door leaf width for a door opening from 0° to 80° or for a closing movement from 90° to 10° door opening angle.

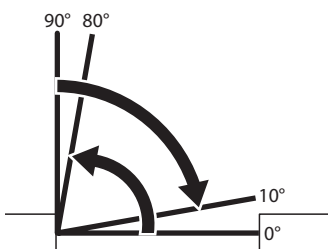

Overview of Powerturn torques

		1. K-BS-rail		2. K-BGS-rail		3. T-BS-rail		4. T-BGS-rail		5. K-BGS-link arm		6. T-BS-link arm	
		Min	Max	Min	Max	Min	Max	Min	Max	Min	Max	Min	Max
EN 1154	EN Class	4	6	5	6	4	6	4	6	6	7	6	7
Closing torques	Nm (Door)	0	60	0	60	0	60	0	60	0	100	0	100
Maximum opening torque (automatic)	Nm (Door)	135		121		143		127		180*		180*	
Manual opening torque (Operating mode Off)	Nm (Door)	10		9		11		10		19		21	

Note: For automatic mode, the doors must be equipped with suitable hinges. A door stop is necessary.

* = Restricted according to DIN 18263-4

BS = Hinge side

K = Transom installation

BGS = Opposite hinge side

T = Door leaf installation

Reveal / max. door opening angle

Transom installation opposite hinge side link arm

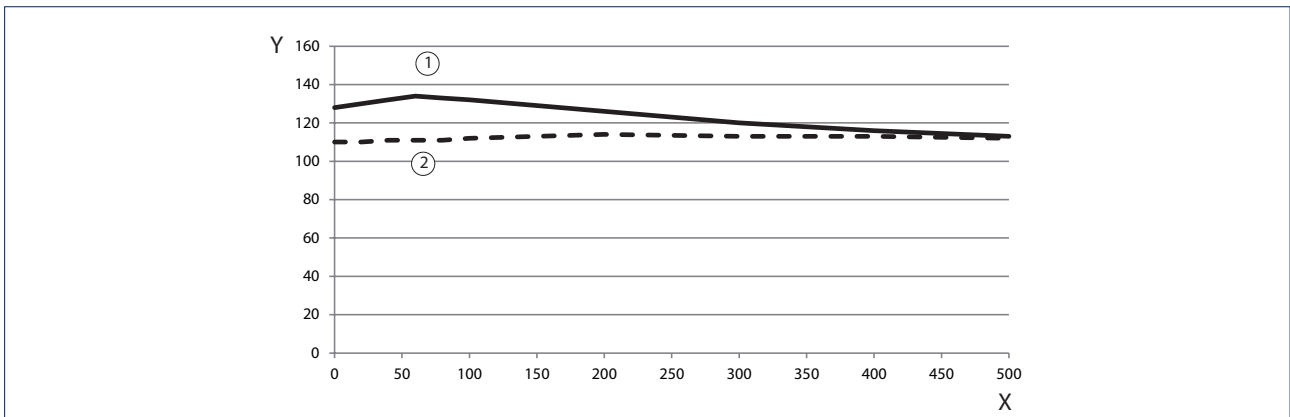

X = Reveal depth (mm)

Y = Max. door opening angle (°)

1 = Door opening angle

2 = Door opening angle with sensor link arm

Transom installation hinge side roller guide rail

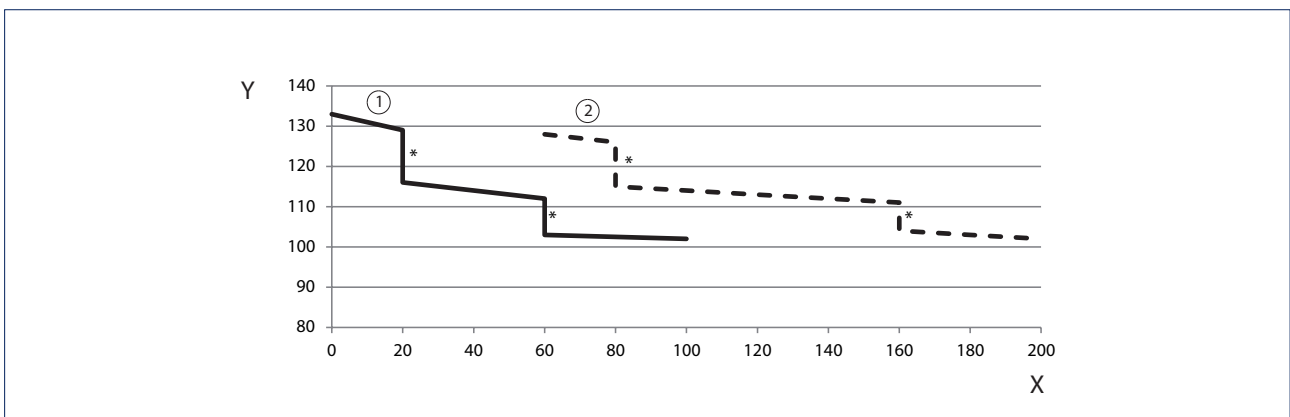

* = Preload

X = Reveal depth (mm)

Y = Max. door opening angle (°)

1 = Lever 330 mm

2 = Lever 450 mm

Transom installation with roller guide rail on the hinge side, 1-leaf and 2-leaf

Drawing no. 70109-ep01

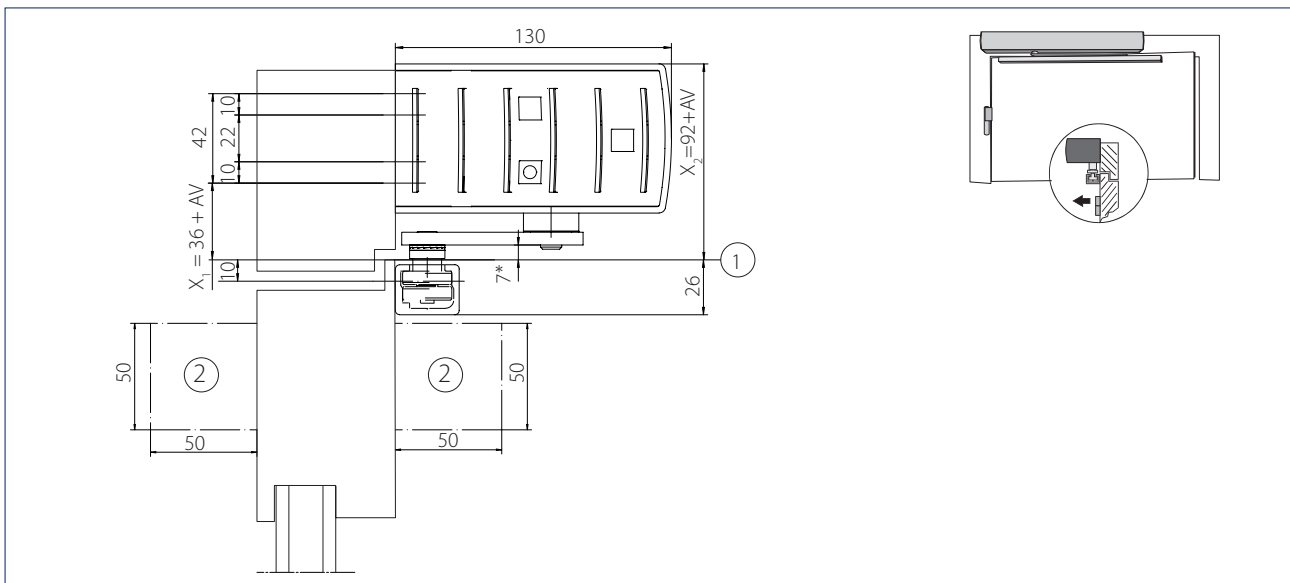

- * = Important functional dimension
- AV = Spindle extension
- 1 = Base upper edge of door
- 2 = Space requirement for sensor strips

Mounting plate fitting dimensions

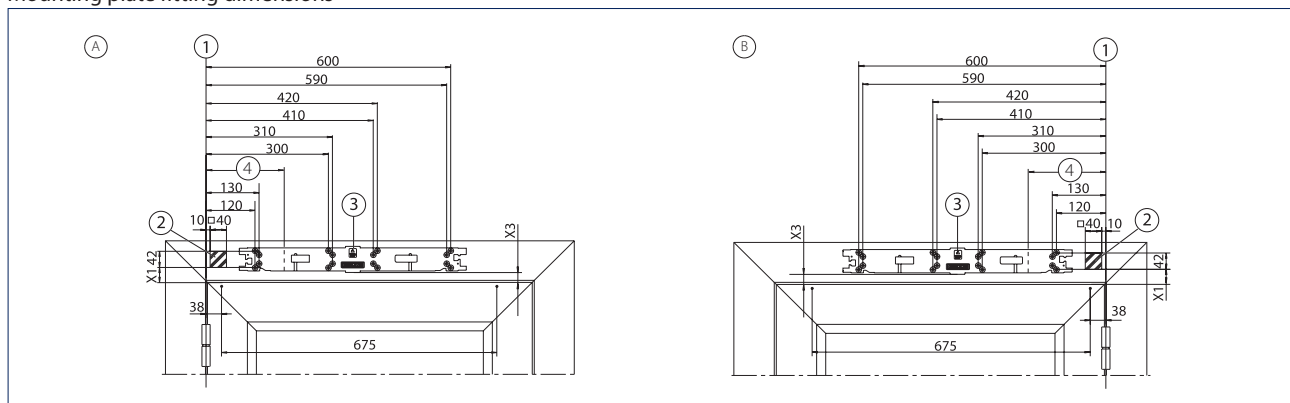

- A = DIN left
- B = DIN right
- 1 = Dimensional reference centre of hinge / upper edge of door
- 2 = Concealed cable routing possible in the hatched area, e.g. Ø 20 mm for the mains connection or low voltage connection
- 3 = Orientation arrow for precise positioning of the mounting plate
- 4 = Hinge size

2-leaf installation with intermediate cover with divided or continuous cover

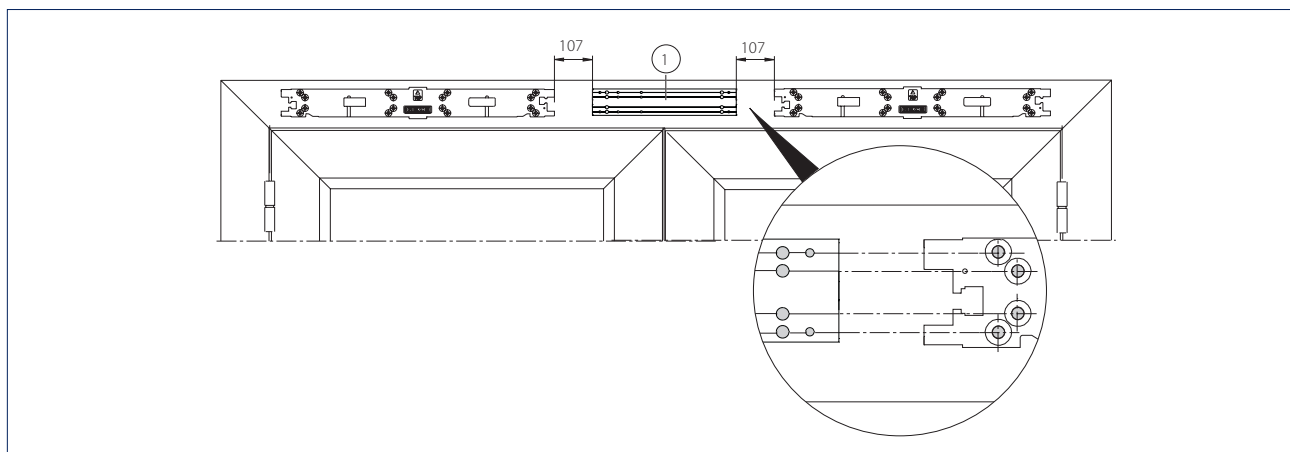

- 1 = Base plate

Transom installation with roller guide rail on the opposite hinge side, 1-leaf and 2-leaf

Drawing no. 70109-ep02

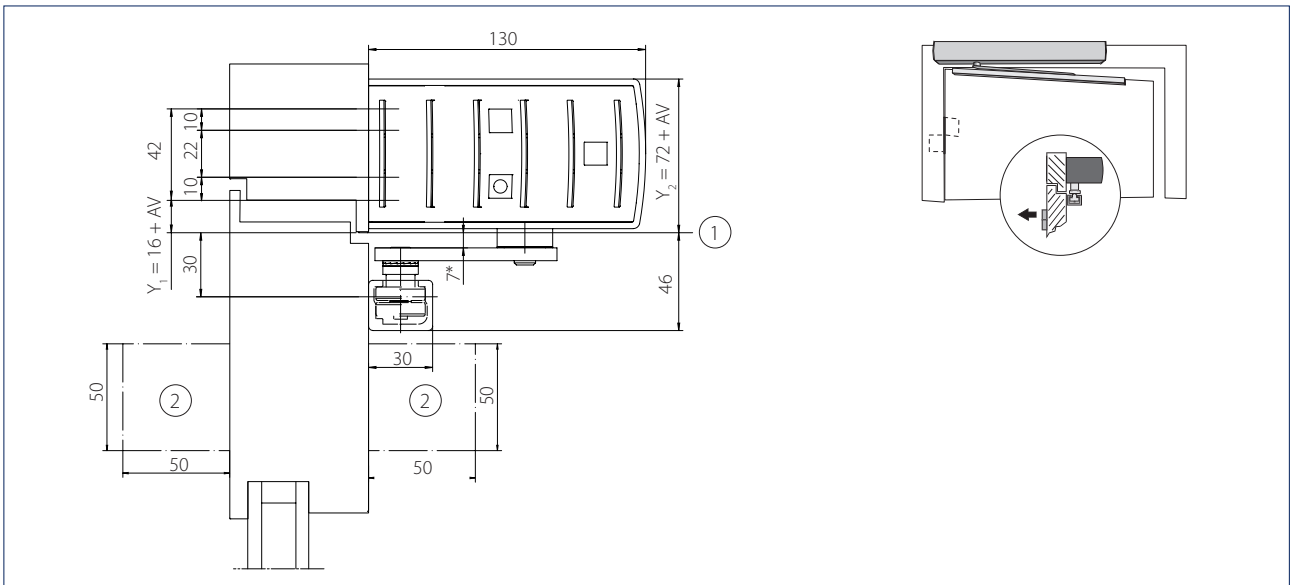

- * = Important functional dimension
- AV = Spindle extension
- 1 = Base lower edge of lintel
- 2 = Space requirement for sensor strips

Mounting plate fitting dimensions

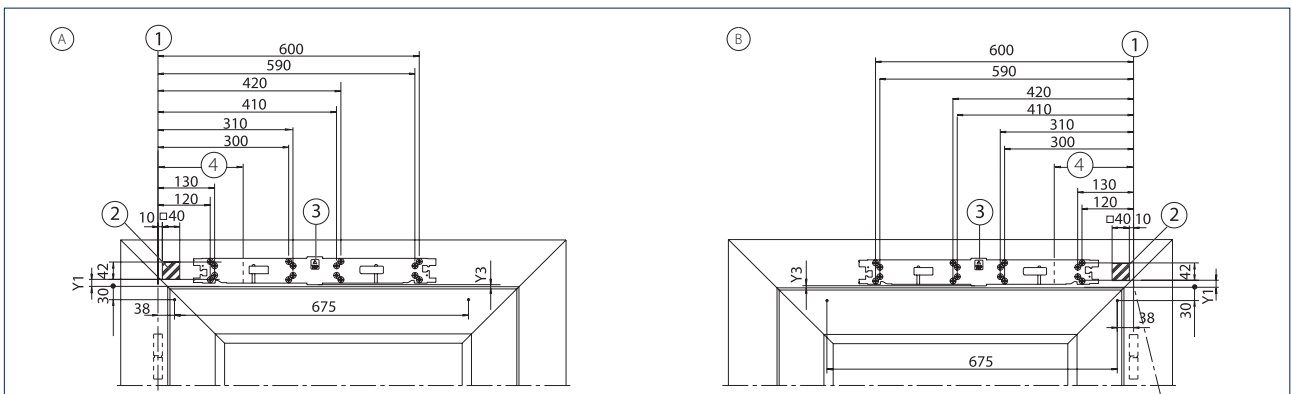

- A = DIN left
- B = DIN right
- 1 = Dimensional reference centre of hinge / lower edge of frame
- 2 = Concealed cable routing possible in the hatched area, e.g. Ø 20 mm for the mains connection or low voltage connection
- 3 = Orientation arrow for precise positioning of the mounting plate
- 4 = Hinge size

2-leaf installation with intermediate cover with divided or continuous cover

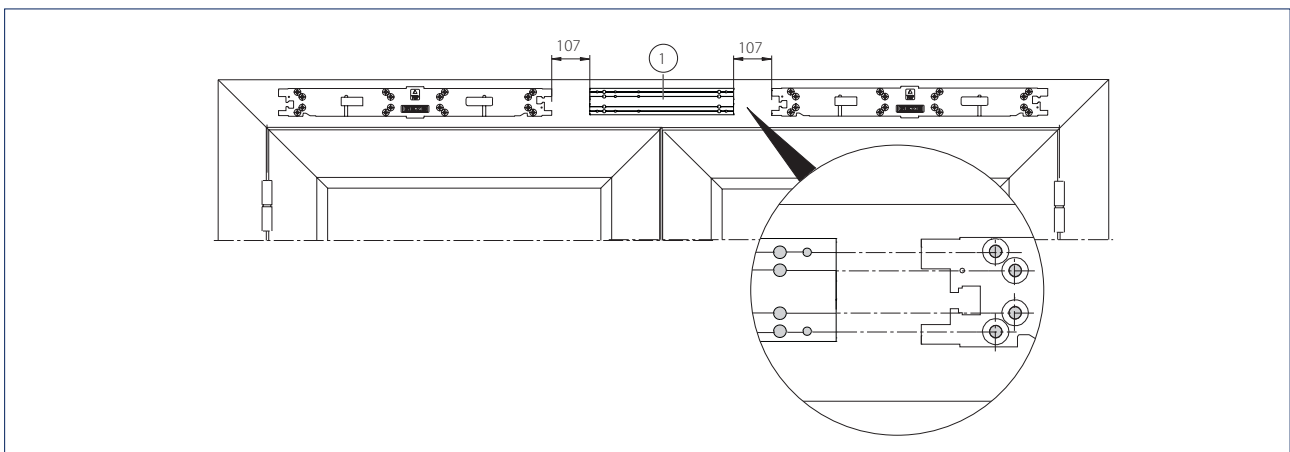

- 1 = Base plate

Door leaf installation with roller guide rail on the hinge side, 1-leaf and 2-leaf

Drawing no. 70109-ep03

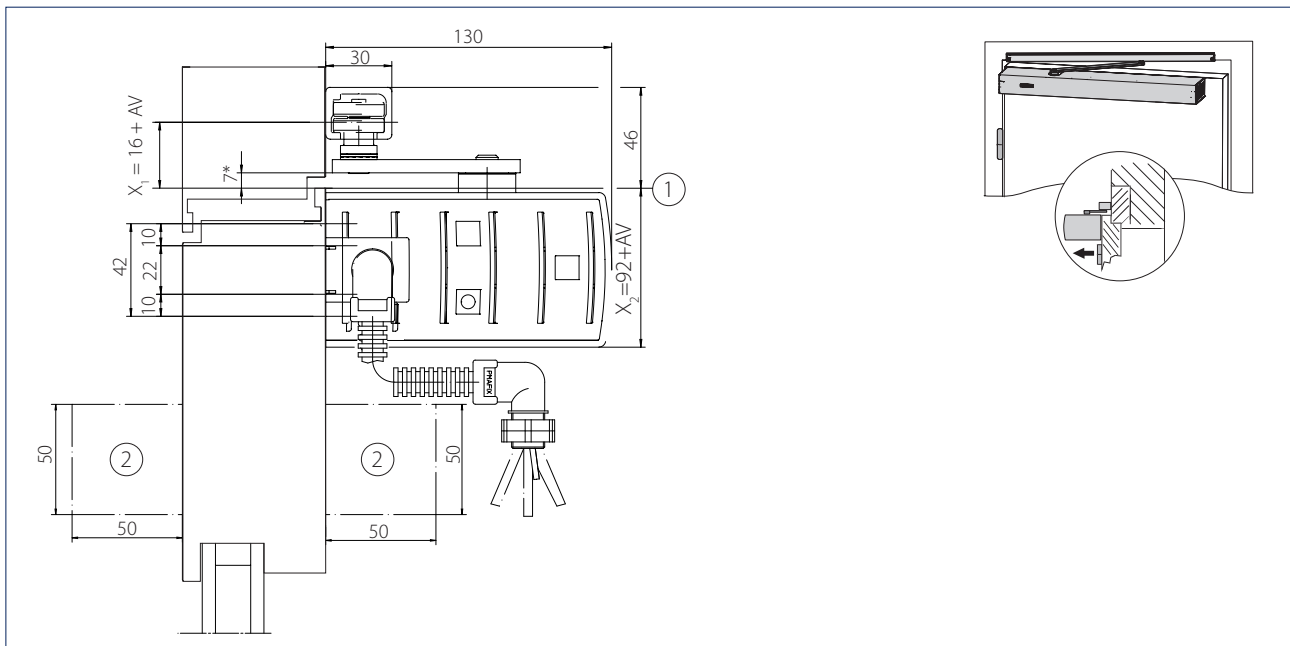

- * = Important functional dimension
- AV = Spindle extension
- 1 = Base upper edge of door
- 2 = Space requirement for sensor strips

Mounting plate fitting dimensions

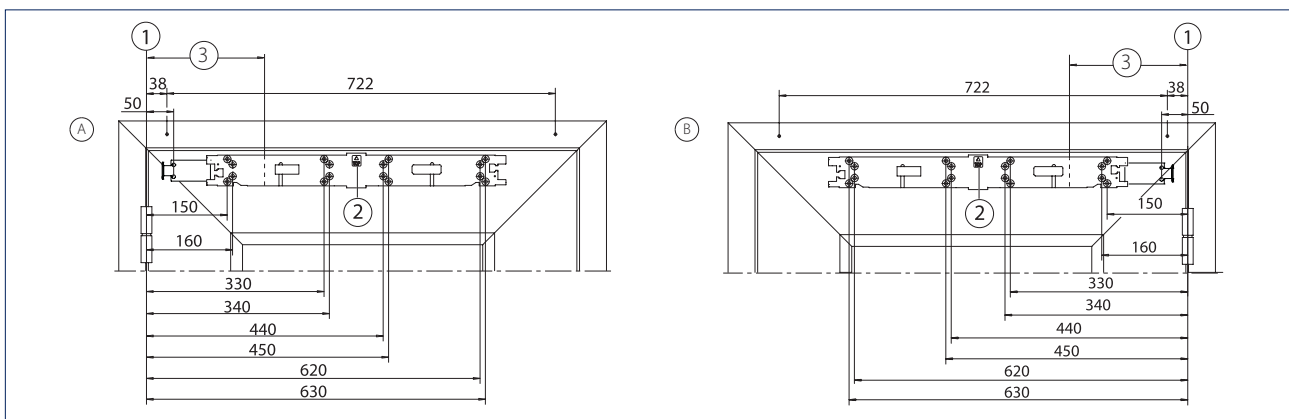

- A = DIN left
- B = DIN right
- 1 = Dimensional reference centre of hinge / upper edge of door
- 2 = Orientation arrow for precise positioning of the mounting plate
- 3 = Hinge size

GEZE POWERTURN

Door leaf installation with roller guide rail on the opposite hinge side, 1-leaf and 2-leaf

Drawing no. 70109-ep04

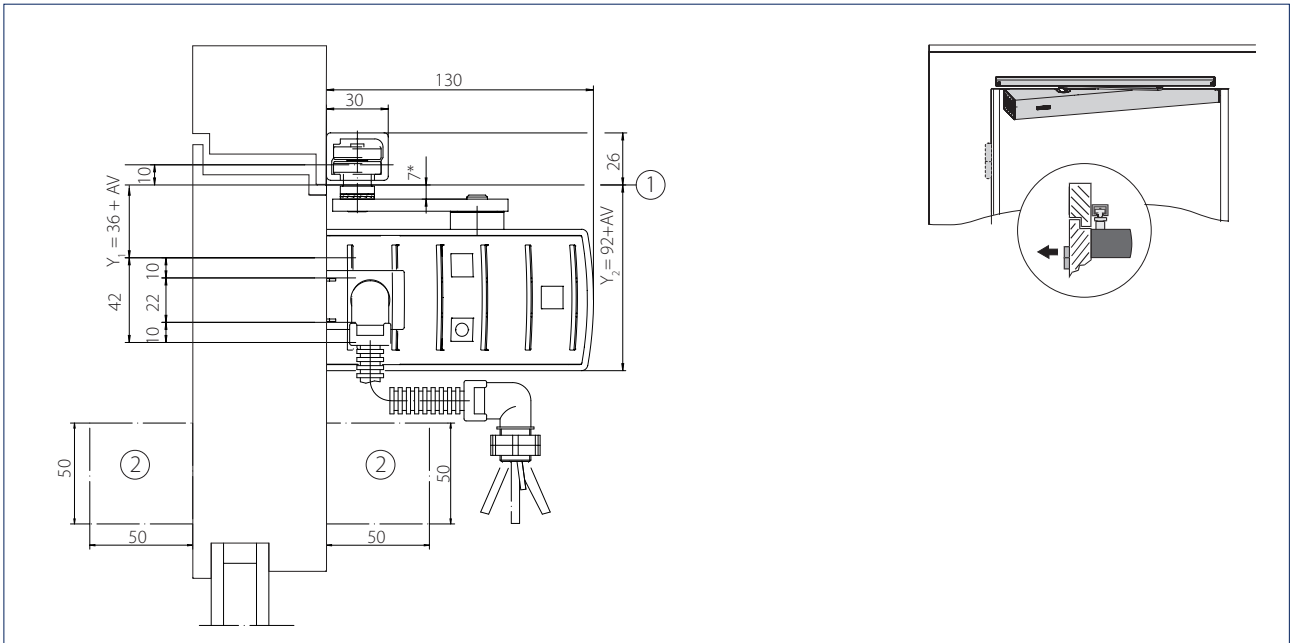

- * = Important functional dimension
- AV = Spindle extension
- 1 = Base lower edge of lintel
- 2 = Space requirement for sensor strips

Mounting plate fitting dimensions

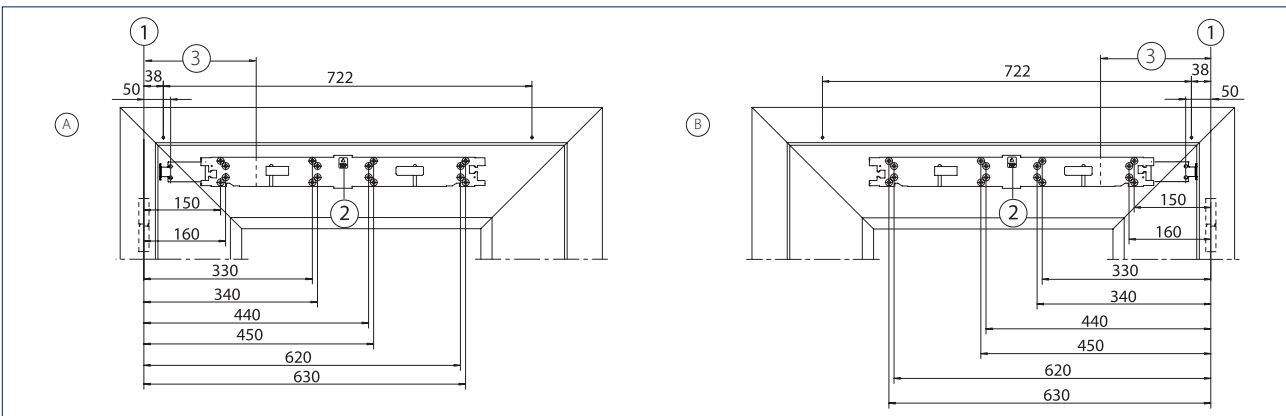

- A = DIN left
- B = DIN right
- 1 = Dimensional reference centre of hinge / lower edge of frame
- 2 = Orientation arrow for precise positioning of the mounting plate
- 3 = Hinge size

Door leaf installation with link arm on the hinge side, 1-leaf and 2-leaf

Drawing no. 70109-ep06

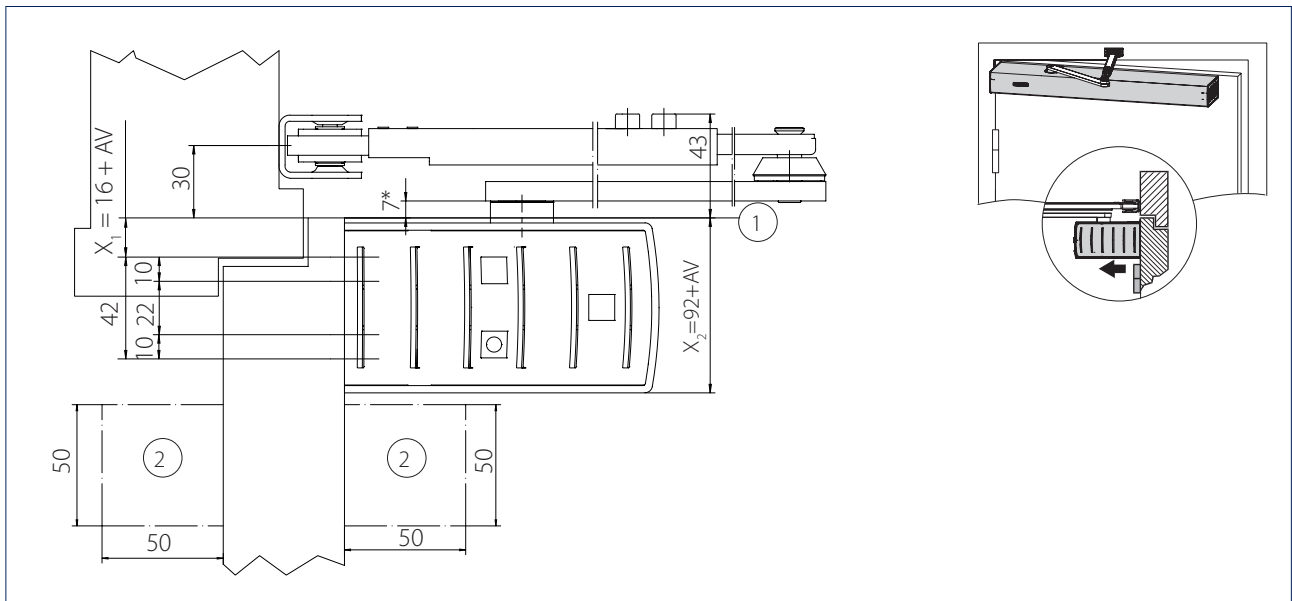

- * = Important functional dimension
- AV = Spindle extension
- 1 = Base upper edge of door
- 2 = Space requirement for sensor strips

Mounting plate fitting dimensions

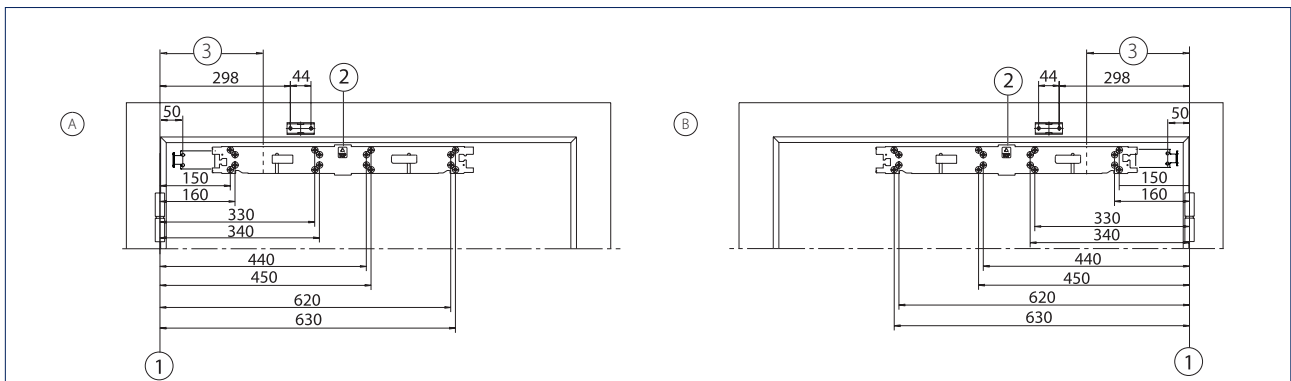

- A = DIN left
- B = DIN right
- 1 = Dimensional reference centre of hinge
- 2 = Orientation arrow for precise positioning of the mounting plate
- 3 = Hinge size

Transom installation with link arm on the opposite hinge side, 1-leaf and 2-leaf

Drawing no. 70109-ep05

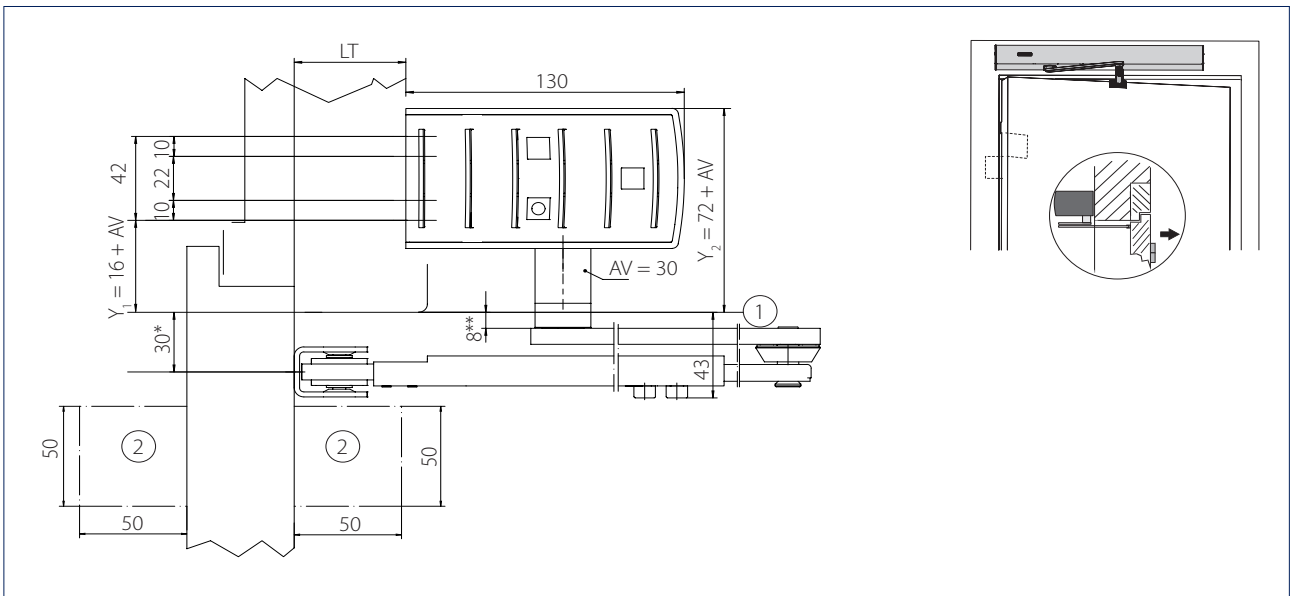

- * = With sensor adapter 35.5 mm LT = Reveal depth
- ** = Important functional dimension 1 = Base lower edge of lintel
- AV = Spindle extension 2 = Space requirement for sensor strips

Mounting plate fitting dimensions

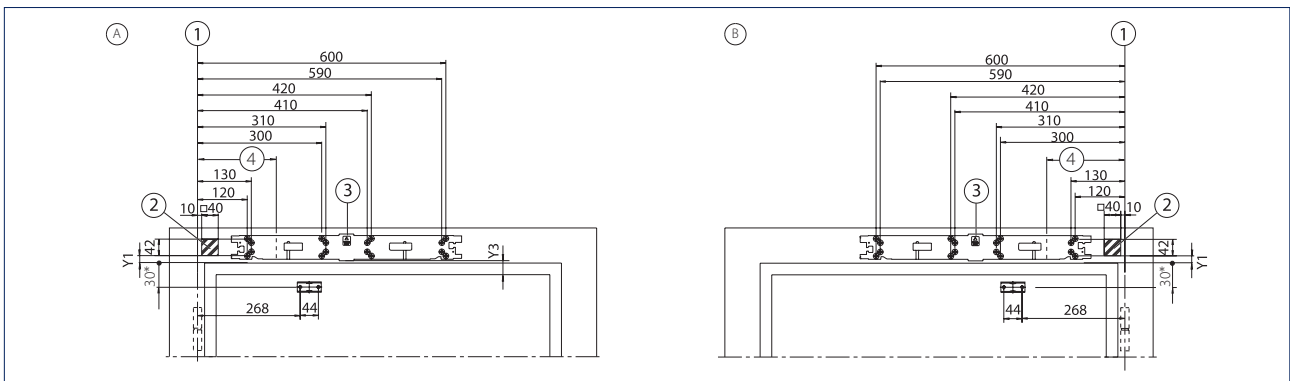

- * = With sensor adapter 35.5 mm 1 = Dimensional reference centre of hinge / upper edge of door
- A = DIN left 2 = Concealed cable routing possible in the hatched area, e.g. Ø 20 mm for the mains connection or low voltage connection
- B = DIN right 3 = Orientation arrow for precise positioning of the mounting plate
- 4 = Hinge size

2-leaf installation with intermediate cover with divided or continuous cover

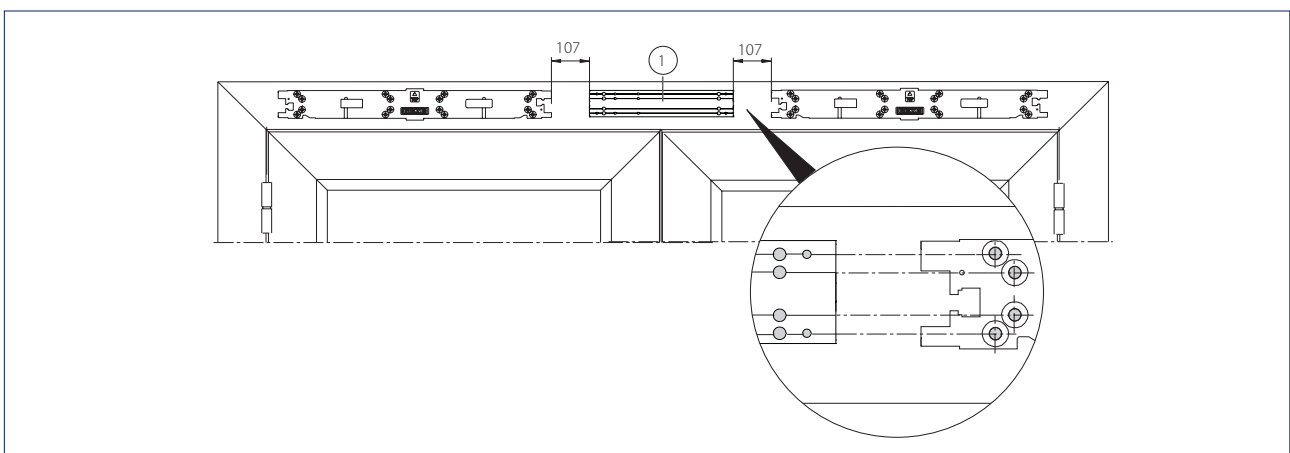

- 1 = Base plate

Powerturn IS/TS: transom installation with guide rail on the hinge side, 2-leaf

Drawing no. 70109-ep21

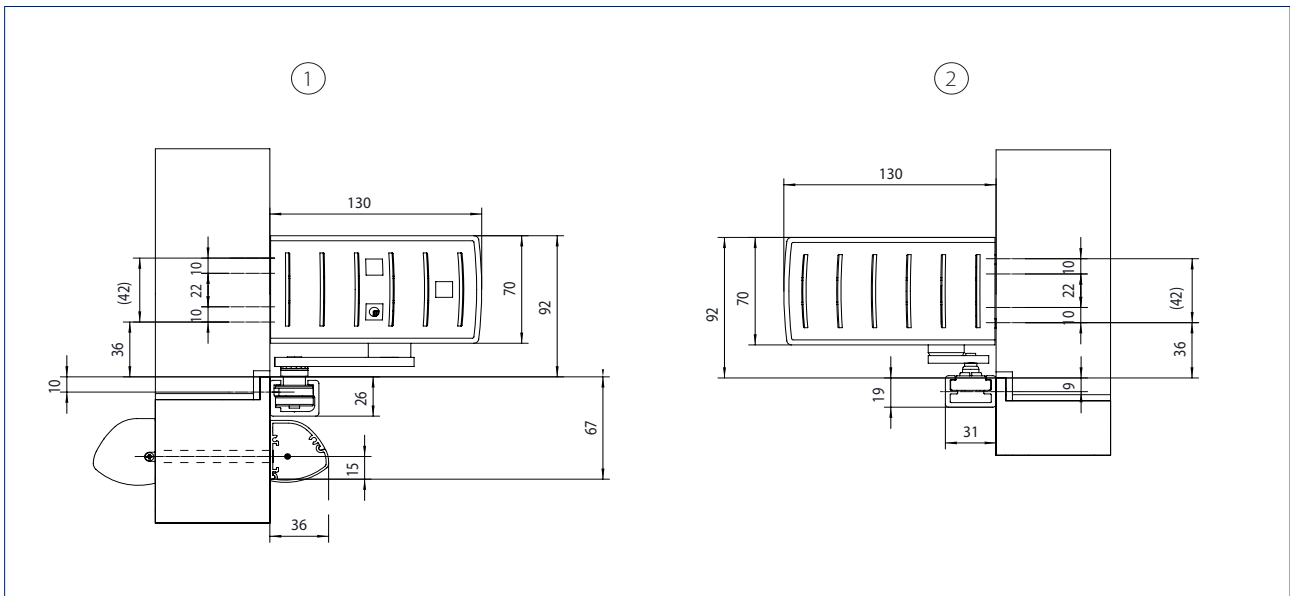

- 1 = Powerturn with roller guide rail and GC 338 sensor strip
- 2 = TS 5000 L door closer with guide rail

Attachment of mounting plate (Powerturn) and base plate (TS 5000 L)

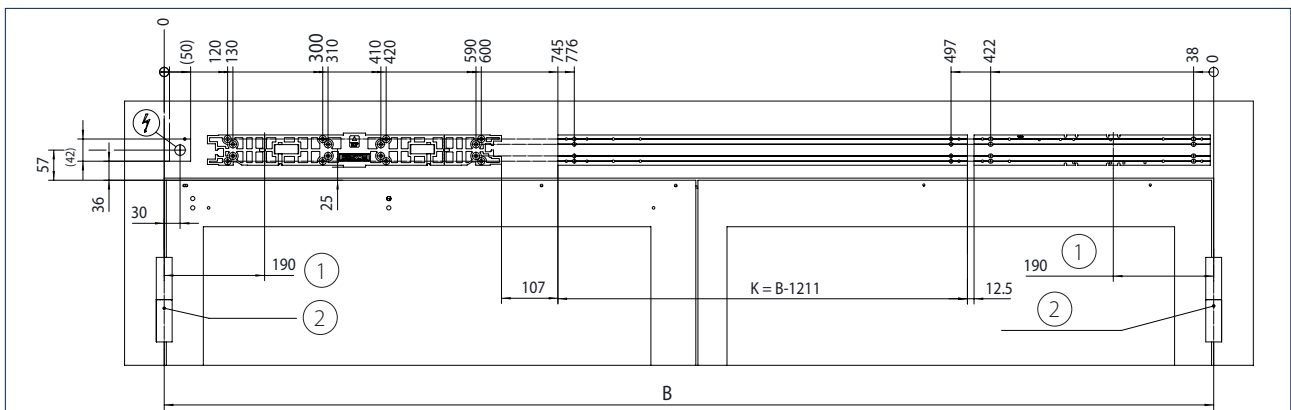

- K = Position of intermediate base plate
- B = Hinge clearance
- 1 = Hinge size
- 2 = Dimensional reference centre of hinge

Maße Rollenschiene (Powerturn), GC 338 und Gleitschiene (TS 5000 L)

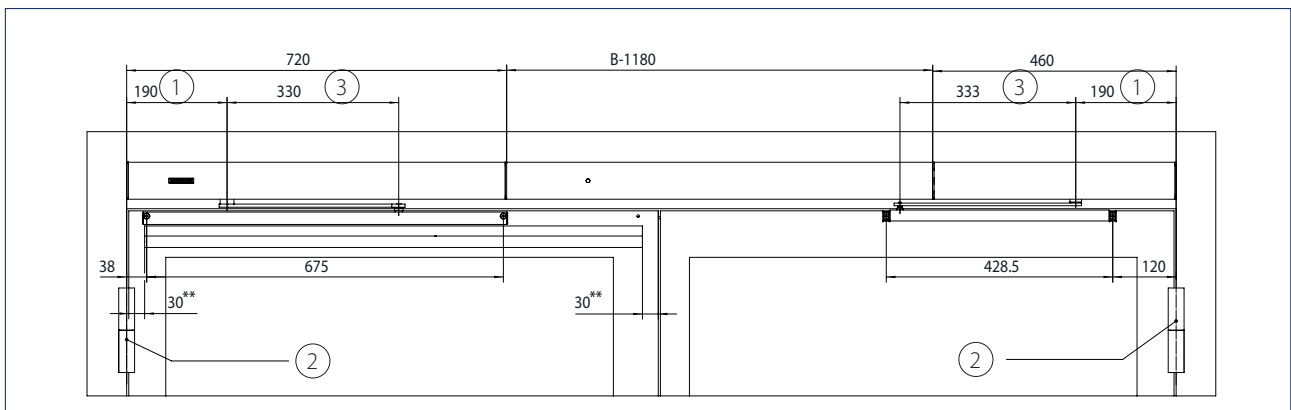

- B = Hinge clearance
- ** = Recommended dimensions for installation of GC 335 and GC 338 sensor strips
- 1 = Hinge size
- 2 = Dimensional reference centre of hinge
- 3 = Lever length

GEZE POWERTURN

Powerturn IS/TS: transom installation with link arm on the opposite hinge side, 2-leaf

Drawing no. 70109-ep25

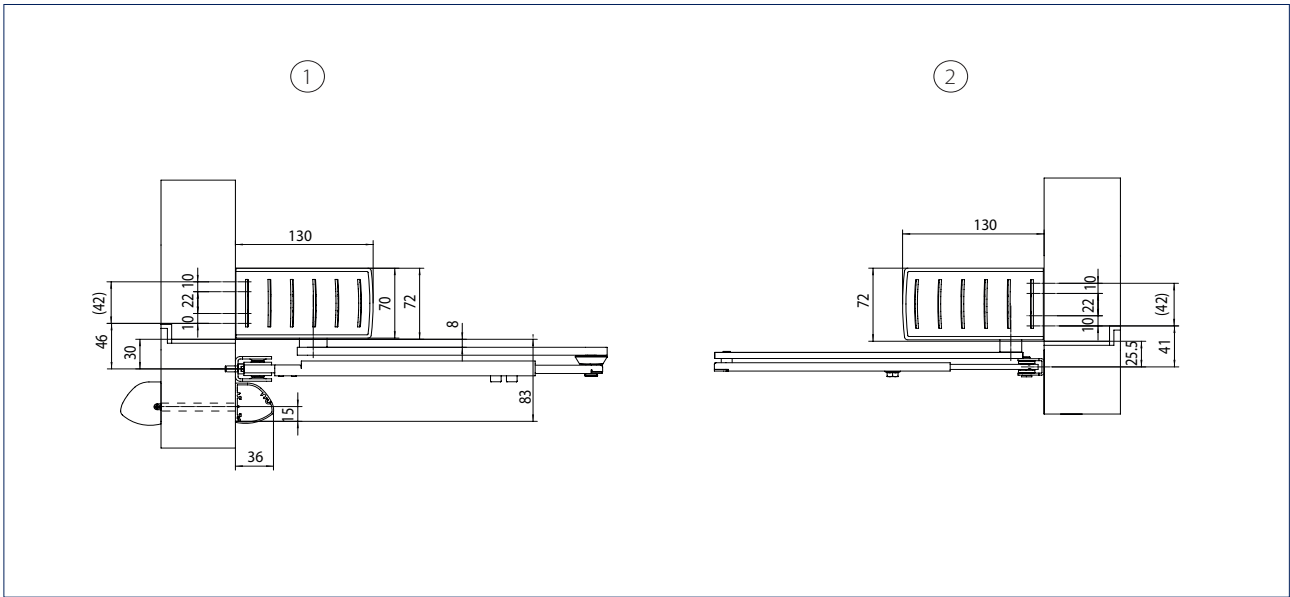

- 1 = Powerturn with link arm and GC 338 sensor strip
- 2 = TS 4000 door closer with link arm

Attachment of mounting plate (Powerturn) and base plate (TS 4000)

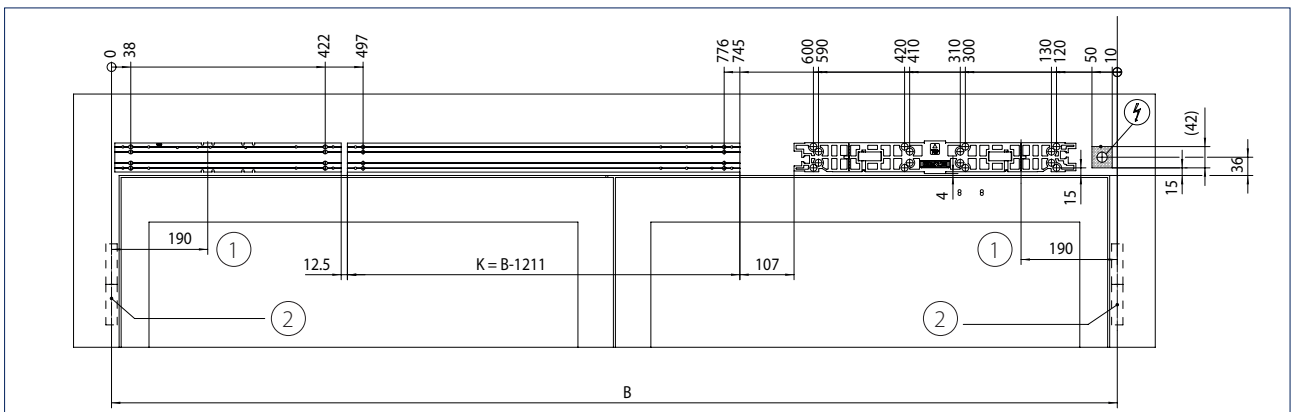

- K = Position of the intermediate base plate
- B = Hinge clearance
- 1 = Hinge size
- 2 = Dimensional reference centre of hinge

Dimensions link arm (Powerturn), GC 338 and link arm (TS 4000)

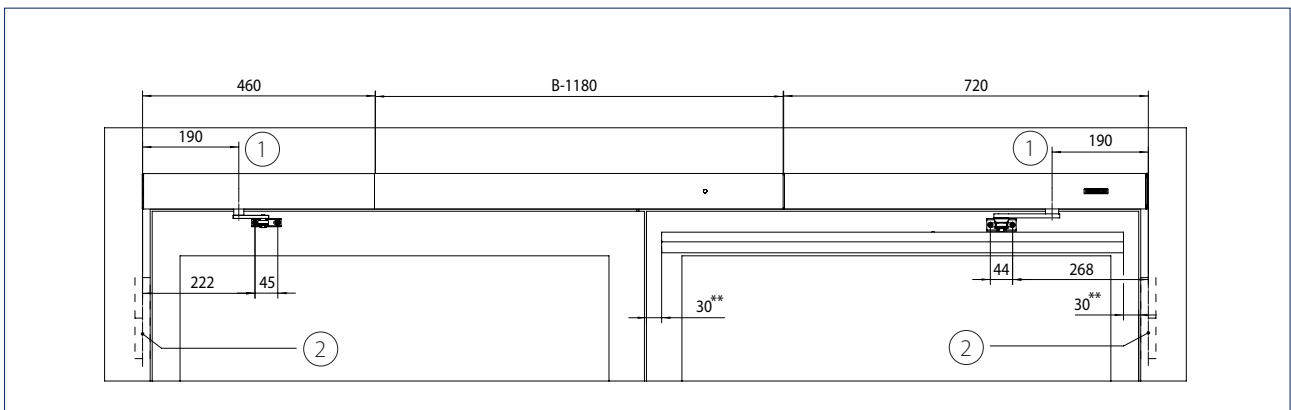

- B = Hinge clearance
- ** = Recommended dimensions for installation of GC 335 und GC 338 sensor strips
- 1 = Hinge size
- 2 = Dimensional reference centre of hinge

Legend for the cable diagrams

Cable

- 1 = NYM-J 3 x 1.5 mm²
- 2 = J-Y(ST)Y 1 x 2 x 0.6 LG
- 3 = J-Y(ST)Y 2 x 2 x 0.6 LG
- 4 = J-Y(ST)Y 4 x 2 x 0.6 LG
- 5 = LiYY 2 x 0.25 mm²
- 6 = LiYY 4 x 0.25 mm²
- 7 = Scope of supply sensor strip or LiYY 5 x 0.25 mm²
- 8 = Route empty pipe with pull-wire inner diameter 10 mm

Notes

- Cable diagrams can also be prepared for specific building projects after receipt of order
- Version of standard cable diagrams in accordance with GEZE specifications
- Cable routing according to VDE0100/ IEE regulations
- Allow the cable for the drive to project at least 1500 mm out of the wall

- 1) Door transmission cable (included in the scope of supply for sensor strip), cable routing through a hole in the door leaf is not permitted for fire control doors.
- 2) Cable exit for door drive, see installation drawings for Powerturn
- 3) Cable included in the scope of supply for the sensor
- 4) Install in the direct vicinity of the door
- 5) Mains connection box WxHxD min. 65 x 65 x 57 with PG-11 duct, on site
- 6) Low-voltage connection box WxHxD min. 94 x 65 x 57 with PG-11 duct, on site
- 7) E.g. door transmission cable, 8-wire, art. no. 066922
- 8) Branch box, on site

Abbreviations

- HS = Main switch
- NOT = Emergency-stop switch
- UT = Circuit breaker CLOSE DOOR (only with F variant)
- KB = Contact sensor authorised
- PS = Programme switch
- ST = Emergency stop
- KI = Contact sensor inside
- KA = Contact sensor outside
- TOE = Door opener
- RM = Bar message
- RS = Smoke switch (only with F variant)
- RSZ = Smoke switch control unit (only with F variant)
- TS = Door closer
- MK = Magnetic contact

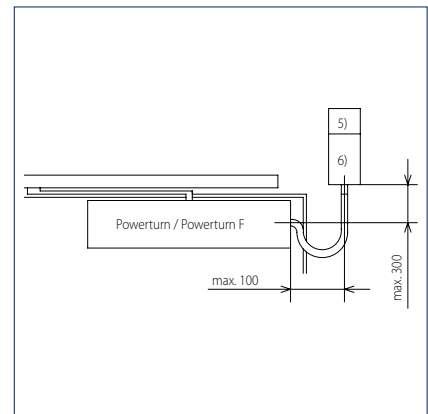
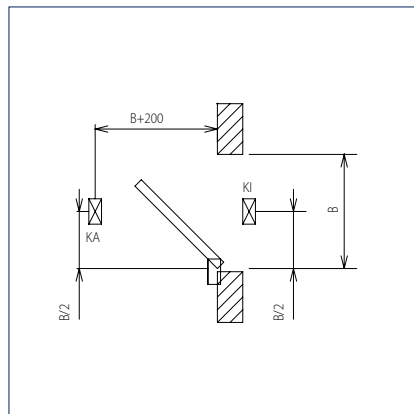
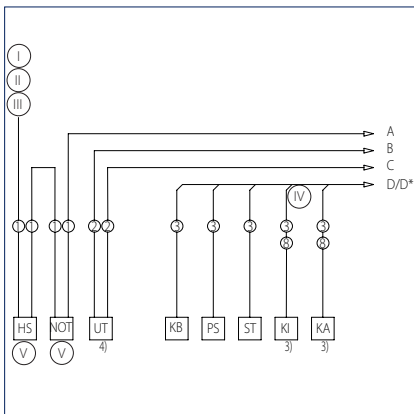

- I = Feeder 230 V / 50 Hz
- II = 10 A fuse
- III = Connected value 230 W, 1 A 1-, 2-leaf with manual fixed leaf; connected value 400 W, 1 A with 2-leaf
- IV = And / Or
- V = Option

GEZE POWERTURN

1-leaf

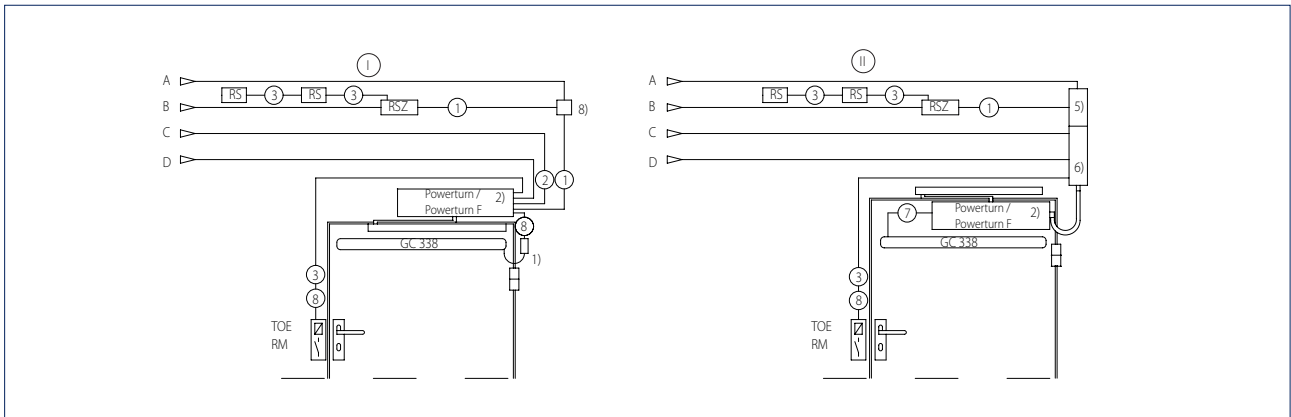

2-leaf

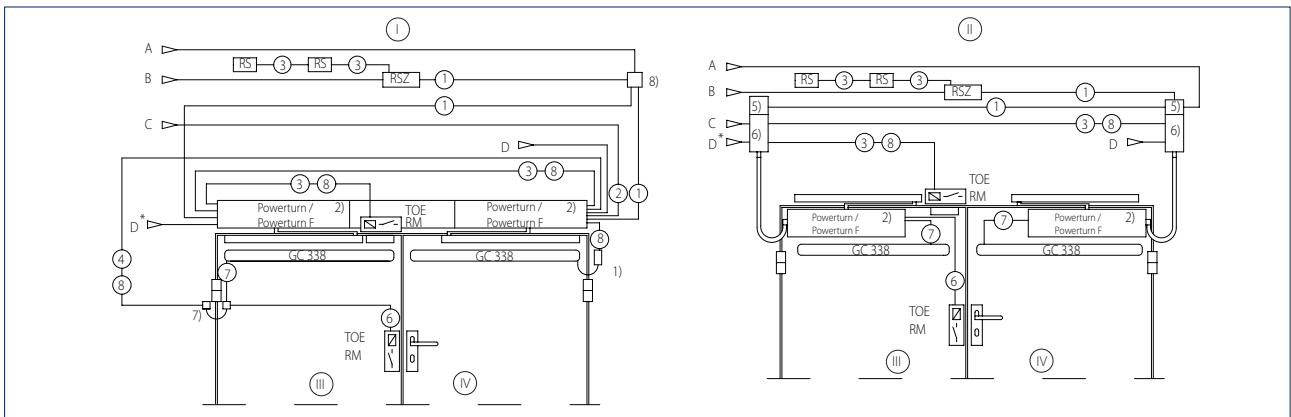

- I = Transom installation
- II = Door leaf installation
- III = Fixed leaf
- IV = Active leaf



Photo: GEZE GmbH

Accessories for swing door systems

Hood, mounting plate, link arm, roller guide rail with lever

Hood

The hood is available in an anodised or coloured finish. In the case of double-leaf versions, the hood can be ordered as a continuous variant or with intermediate hood.

Mounting plate for drives (option)

A mounting plate may be necessary, depending on the installation situation. A mounting plate is generally recommended to make installation easier. A respective mounting plate is supplied according to the hood version.

Link arms

are offered for different reveal depths

Roller guide rail with lever

Installation depends on the type of hinge action chosen.

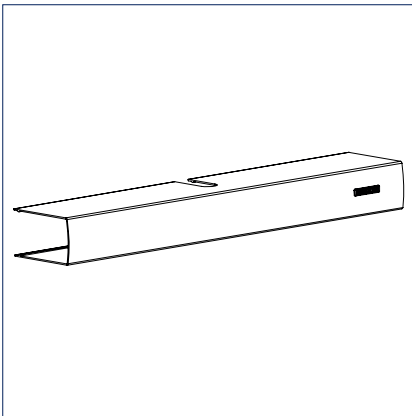

Cover

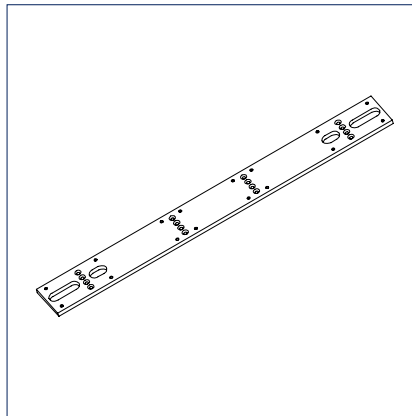

Mounting plate

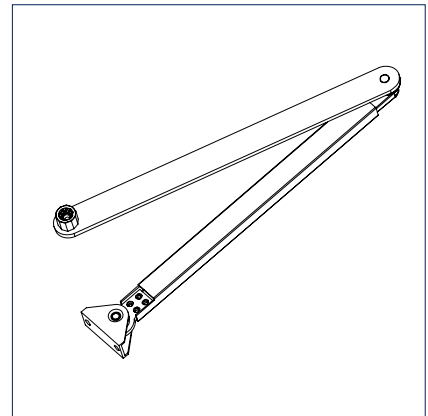

Link arm

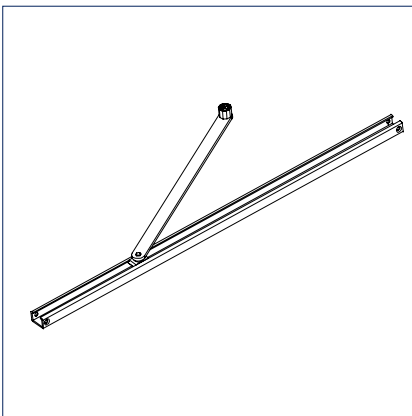

Roller guide rail / guide rail with lever

Operating automatic swing doors

Programme switches for the selection of the operating mode for automatic swing doors

Note

More detailed information on the following accessories can be found in the catalogue: **GEZE activation devices and sensor systems**

GEZE offers programme switches for a wide range of individual requirements. The switches are suitable for universal use – for surface-mounted or flush-mounted installation. The following switch types are available:

Display programme switch (DPS)

Key programme switch (TPS)

Mechanical programme switch (MPS)

The following operating modes can be set:

“Permanently open”

The door moves to the OPEN position and remains open. Movement detector or opening button are deactivated.

“Night”

The movement detectors are switched inactive, the door closes. The door can only be opened with contact sensor authorised (KB) or manual release. Option: The door leaves are locked electrically to prevent forced opening.

“Shop closing” (One-direction operation from the inside to the outside)

The door only opens and closes when someone goes out from the inside.

The movement detector outside is switched inactive, the one inside is switched active.

“Automatic”

The door opens as soon as it is actuated via the movement detector or keys, and closes after a certain individually adjustable time. Safety sensors protect the leaves’ travel path. If there is someone in the door opening, the door will not close.

“OFF” (depending on model)

Drive motor, locking, activation and safety sensors are switched off, the door leaves can be moved manually.

Key switch

The programme switch can be blocked using a key switch.

Securing the programme switches

The mechanical programme switch (MPS) is also available in a lockable version. The display programme switch (DPS) and key programme switch (TPS) can be combined with a key switch. Alternatively, the DPS and TPS programme switches can be secured using a code.



Display programme switch (DPS)



Key programme switch (TPS)



Mechanical programme switch (MPS)

Automatic activation

Reliable activation with GEZE sensors

Radar movement detector

Radar movement detectors register all objects that move within the radar field. All movements within the radiation range are recorded as a switching pulse which is forwarded as a door opening signal. The pre-programmed convenience setting of the GEZE radar movement detectors ensures they can be put into operation quickly. Automatic configuration is possible via keys or a remote control. Reliable detection is achieved with a clearly defined radar field. Energy can be saved through detection of people's direction of movement. Excessive door opening is avoided since cross-traffic can be faded out.



Radar movement detector GC 304



GEZE TSA 160 NT IS and radar movement detector, Andels Hotel, Berlin, Germany (Photo: Stefan Dauth)

Manual activation

Push buttons

GEZE push buttons for the wireless activation of system doors – reliable, convenient and safe at the push of a button.

Capacitive push button

The design-oriented and sturdy LED sensor button makes intuitive and straightforward operation possible. No great efforts are required for activation – touching the button slightly is sufficient. Suitable for use both indoors and outdoors, the LED sensor button can be recognised easily in the dark thanks to the blue LED lighting. In addition, the sensor has raised Braille lettering on it. A visual signal initiates activation through the push button. The push button is waterproof, impact-resistant and vandalism-proof. This makes it very well suited for outdoor use or installation in the floor.

Non-contact proximity switch

Open doors in a flash: With GEZE infrared sensors, internal doors without precise perception requirement can be actuated cleanly and comfortably. Active infrared sensors ensure hygienic access to toilet facilities, for example. The risks of infection are also minimised in hotel kitchens, hospitals and doctors' surgeries. The impulse generator is installed at hand height and precisely detects people and objects – independently of their direction of movement – both in the direct vicinity of only 5 cm as well as 0.6 m away. The different scanning ranges can be optimally adapted to existing environmental conditions and the wishes of the user groups. The non-contact sensor system provides maximum operating convenience – people only need to approach them to trigger the automatic opening mechanism. The optimum system structure permits simple and time-saving installation in the flush-mounted box.

Radio activation

GEZE radio transmitters are used for wireless activation of doors and windows as a multi-channel solution. For every additional channel, an additional electrical device or function can be switched at the push of a button. Thanks to the very small size of the radio modules, radio transmitters can easily be integrated in the drive or in a flush-mounted box. They can also be clipped directly into the elbow switched and mounted without wires on glass.



Push button



LED sensor button



Non-contact proximity switch GC 306



Radio activation



Plastic elbow switch



Stainless steel elbow switch IP65

Electronic protection

Safety sensor strips

Safety sensor strips are used to monitor and safeguard the pivoting area of automatic swing door leaves. They are installed on both sides of the door, directly on the leaf. This guarantees maximum protection both during opening and closing of the door.

GEZE safety sensors work with infrared light. Electromagnetic waves which are invisible to the human eye record people or objects within the area of detection. A receiver absorbs the reflected infrared beams and converts them into an electric signal which is transmitted to the control unit of the door drive. Door movement in the opening direction is stopped as soon as the sensor registers an obstacle. It is possible for the wall areas to be faded out by the safety sensors (teachable). In closing direction, the sensor actuates the drive of the closing door and opens it again.

GC 338 sensor strip

The energy- and space-saving sensor strip GC 338 has a very large safety range and offers enhanced protection on the primary and secondary closing edges. In addition, the sensor has a wall blanking feature which makes it possible to guarantee maximum safety even with doors that open against walls. Safeguarding all GEZE swing door drives with door leaf widths of up to 1500 millimetres is achieved with only one sensor system. The GC 338 not only offers advantages for installation and commissioning – the complete door system is supplied via an interface. The sensor strip automatically adapts to its environment. This saves learning time and installation costs. The GEZE sensor strip GC 338 has the following features:

- Reliable function under all weather and floor conditions up to 3.5 m in accordance with DIN 18650 / EN 16005
- One sensor system safeguards door leaf widths of up to 1500 mm
- Wall blanking: The sensor can detect a wall and blank this out automatically
- Elegant roller guide rail can even be used with slim door profiles
- Current consumption in operating mode: 200 mA
- Quick and easy installation of the modules using the SNAP-IN mechanism, allowing modules to be positioned and fixed in the profile without tools



GC 338 sensor strip

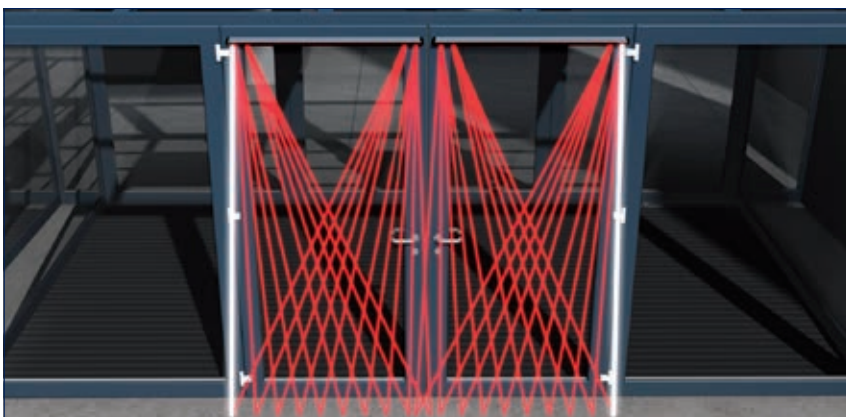

Frontal detection field



Integrated wall blanking

ACCESSORIES

Safety sensors on door leaf with vertical handle bars

To secure the door in accordance with DIN 1860 / EN 16005, the following modules are required additionally for each door side:

- 1 transmitter module
- 1 receiver module

Please find more details in the GC 338 operation manual.

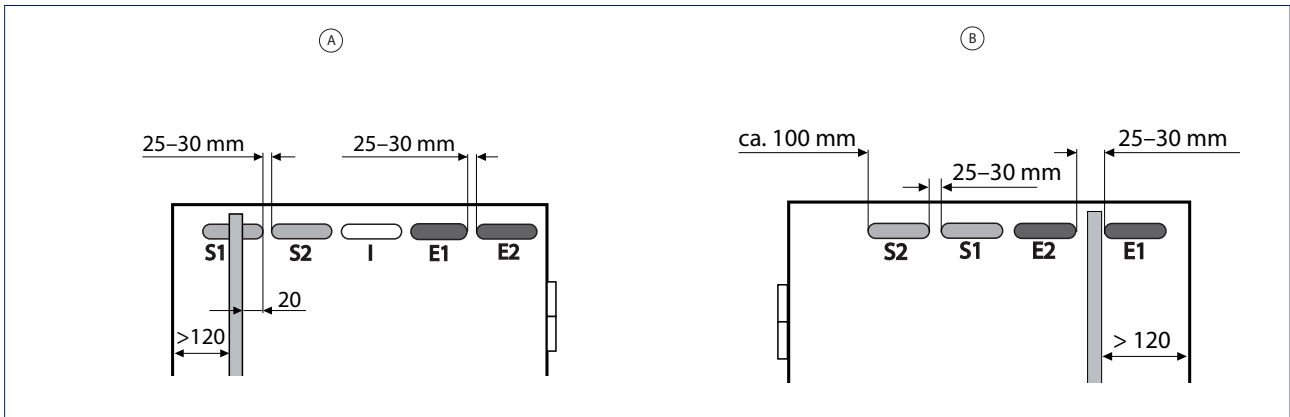

- A = Handle bar left
- B = Handle bar right

Installation on the hinge side

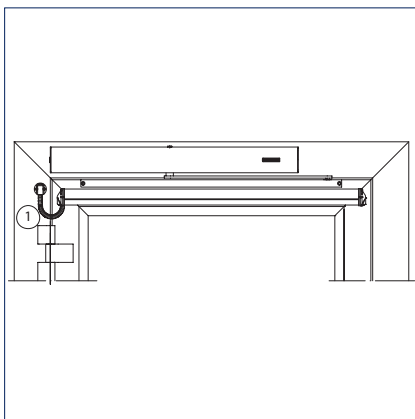

Safety sensor „open“ mounted on the hinge side

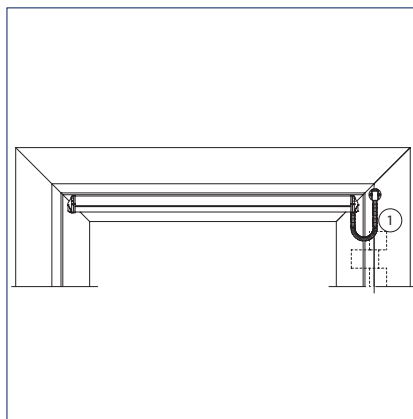

Safety sensor „close“ mounted on the opposite hinge side

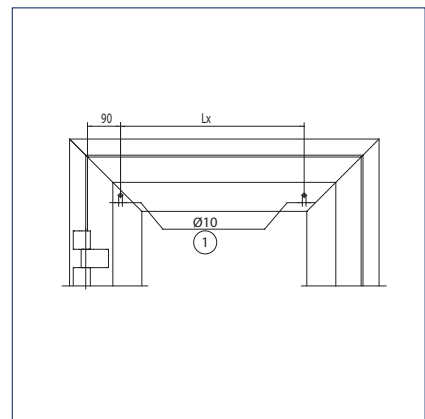

Safety sensor drill hole distances hinge side

Installation on the opposite hinge side

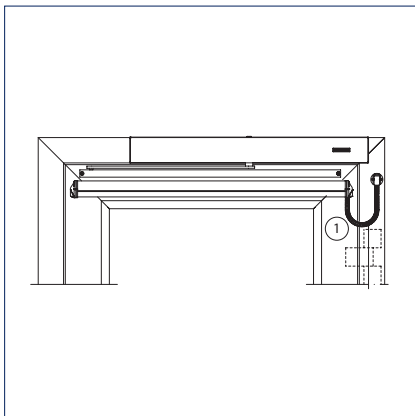

Safety sensor „close“ mounted on the opposite hinge side

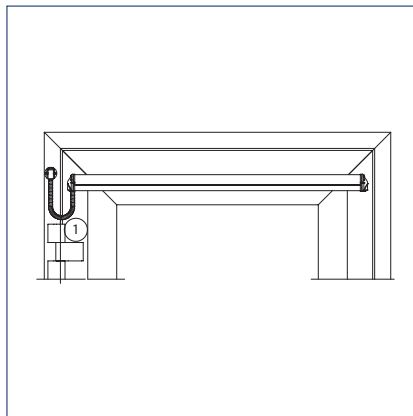

Safety sensor „open“ mounted on the hinge side

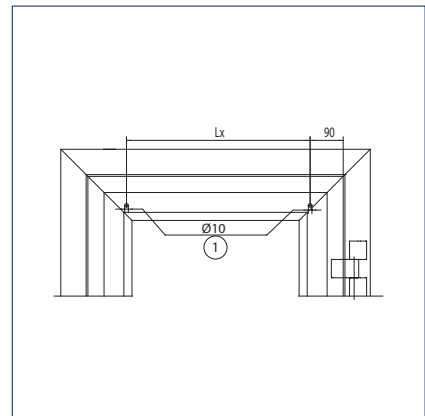

Safety sensor drill hole distances opposite hinge side

1 = optional power supply, concealed routing possible. Drill hole Ø 10 for concealed cable routing.

Lx = Profile length 1100 mm : Lx = 489 mm; profile length 1500 mm : Lx = 699 mm

Sensor roller guide rail GC GR - the ideal combination of safety and design

The GC GR sensor roller guide rail is available for the complete range of Slimdrive EMD models as well as all the TSA 160 NT and Powerturn drive versions. The sensor and the roller guide rail can be put together in such a way that they look like a single compact and more integrated design. The features at a glance:

- Suitable for single and double-leaf swing door
- Available for all TSA 160 NT, Slimdrive EMD and Powerturn variants with roller guide rail
- Sensor and roller guide rail profile are available separately, facilitating retrofittings to existing systems
- The rain cover is available as accessory

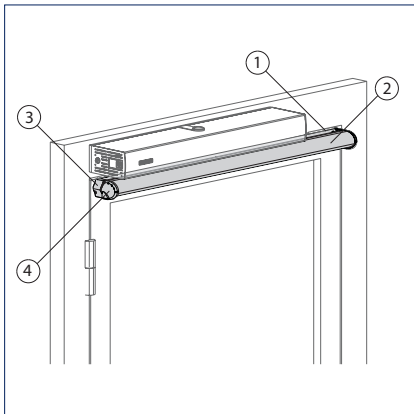

- 1 = Sensor roller guide rail
- 2 = Sensor strip
- 3 = End cap for sensor roller guide rail
- 4 = End cap for sensor strip



Sensor roller guide rail GC GR



Adapter for sensor and link arm for slimdrive EMD and TSA 160 NT - Integration of link arm and sensor strips on one level

Exactly similar as in case of the sensor roller guide rail GC GR, the newly introduced adapter for link arm and sensor enables an optimal installation on doors with slim frames. The link arm program of the Slimdrive EMD and TSA 160 NT drives was re-worked, so that the adapter can be combined with new link arms. Advantages:

- Better integration of link arm and sensor strip GC 338, GC 335 or GC 338 into the door design
- Simple installation, in particular in case of slim door frames
- With the new link arms a maximum reveal depth of 400 mm can now be bridged

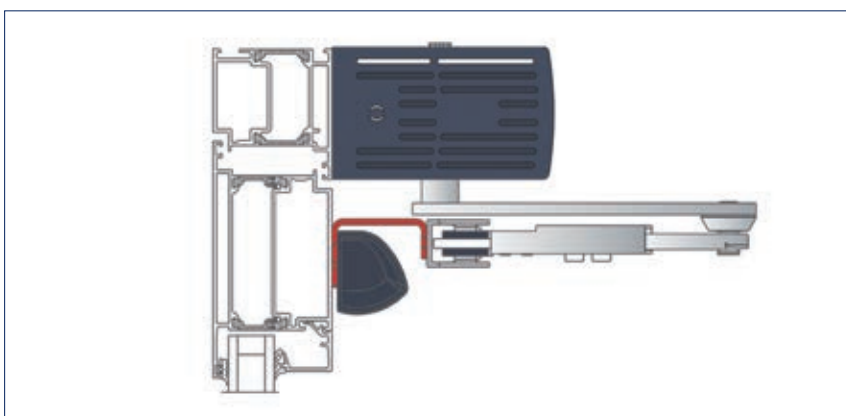

Adapter for sensor and link arms for Slimdrive EMD and TSA 160 NT

ACCESSORIES

EMD and GC GR (GC 338) transom installation with roller guide rail on the hinge side

Drawing no. 70106-ep35

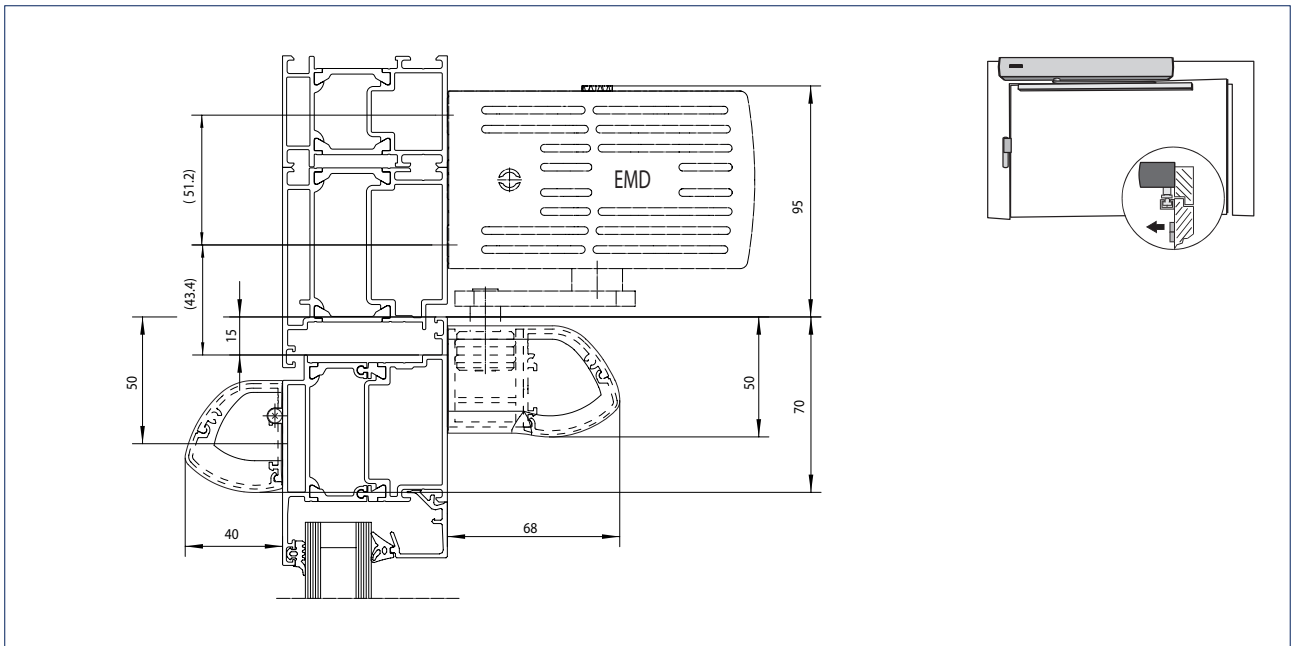

EMD and GC GR (GC 338) transom installation with roller guide rail on the opposite hinge side

Drawing no. 70106-ep35

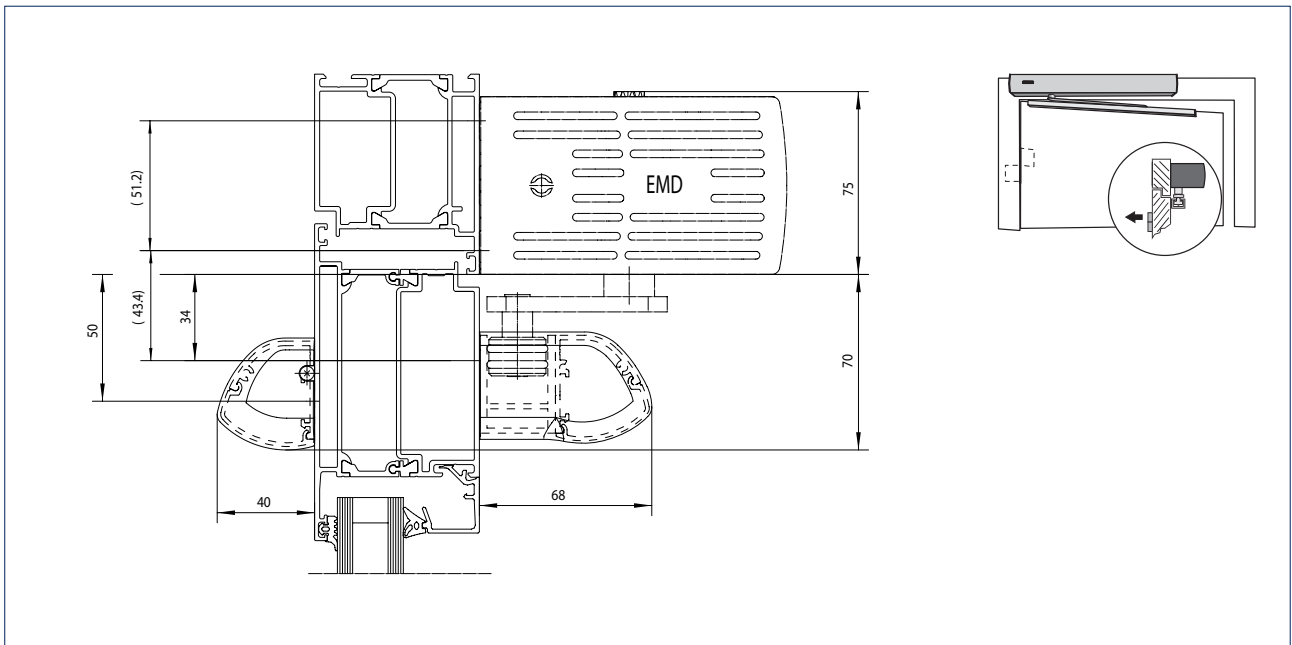

TSA 160 NT and GC GR (GC 338) transom installation with roller guide rail on the hinge side

Drawing no. 70106-ep35

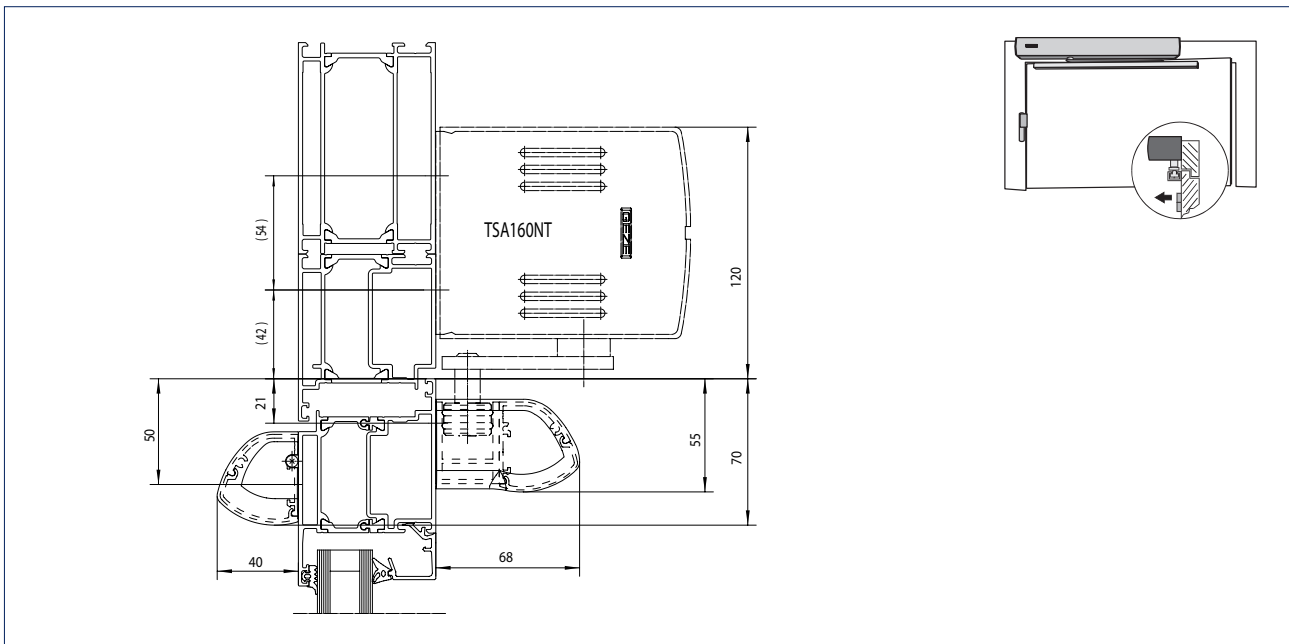
**GC GR (GC 338) 1200 mm with roller guide rail, single leaf**

Drawing no. 70106-ep35

Note: For double-leaf doors mirror and add this view.

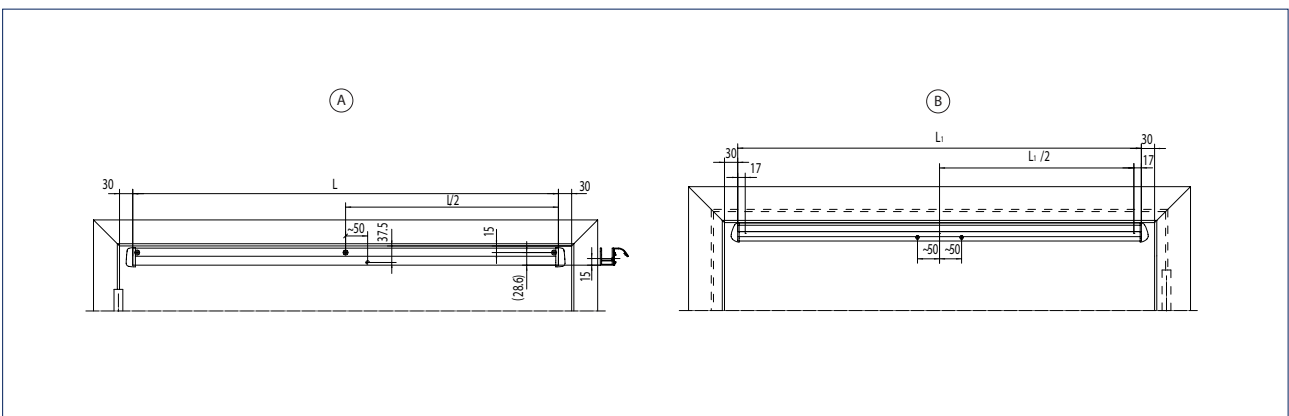

- A = Hinge side
- B = Opposite hinge side
- L = Length

ACCESSORIES

GEZE laser scanner GC 342

Laser scanner for the protection of automatic swing doors in compliance with DIN 18650/EN 16005

The compact and space-saving GEZE sensor GC 342 serves to protect automatic swing doors in compliance with DIN 18650/EN 16005. The sensor is preferred for use with difficult floor conditions (e.g. floor mats, metal runners, dark and absorbent floors). A large field of detection ensures protection of the main and secondary closing edges, with a wide recording field across the entire width of the door. The sensor also has wall blanking, guaranteeing maximum security even with doors that run against walls. The GC 342 automatically learns its environment. With just one sensor system, the safety of all GEZE swing doors drives up to door leaf widths of 1600 mm can be achieved.

Thanks to the integrated wall blanking, the sensor learns its permanently installed environment – walls, radiators, windowsills. The parameter adjustment of the wall blanking in the drive can be omitted. The installation on the upper edge of the door near the hinge is cleverly solved and therefore is quick and easy to achieve. The door leaf width to be locked is learned using hand movements. Settings such as the position of the master module on the hinge side/opposite hinge side, immunity, background monitoring and monitoring of the secondary closing edge can be handled easily using dip switches.



Photo: GEZE GmbH

Service Tools

GEZEconnects

Bluetooth is an internationally standardised short-distance radio signal with a range of up to ten metres. The software GEZEconnects makes wireless connection via Bluetooth possible between a computer and the automatic door systems from GEZE. All door system settings can be carried out via an intuitive graphic interface, stored, sent by e-mail and transferred to a word processing programme as a protocol. Diagnosis functions show the most important function parameters of the door system in real time, so that problems are recognised at a glance and can be eliminated. All the pre-settings can be taken over very easily for further door systems. The convenient documentation of initial operation, servicing and diagnosis protocols as well as all statistical data can be downloaded at any time. Password protection to freeze operating parameters and servicing data guarantees there will be no unauthorised modifications made.

Service terminal ST 220

Mobile, handy and straightforward – that is the parameter setting for the automatic GEZE door systems using the service terminal ST 220. Communication and data exchange between the service terminal and the door drive is via an integrated RS485 interface. The large illuminated display is easy to operate thanks to the plain text display. The service terminal is equipped with a readout function for servicing and diagnosis work. Power is supplied via the door system. Password protection to freeze operating parameters and servicing data guarantees there will be no unauthorised modifications made.

A service adapter for the ST 220 which is available separately can be laterally inserted from the outside into the drive, allowing operating parameters and service data to be read out and parameters to be set without the drive cover having to be removed.

Notes

- GEZE service tools are available for the Slimdrive EMD, TSA 160 NT and Powerturn range of drives.
- Parameters of GEZE drives may only be changed by technicians trained in accordance with DIN 18650/EN 16005 and authorized by the manufacturer (GEZE).



GEZEconnects



Service terminal ST 220



Service adapter for ST 220



Bluetooth service adapter for ST 220

References

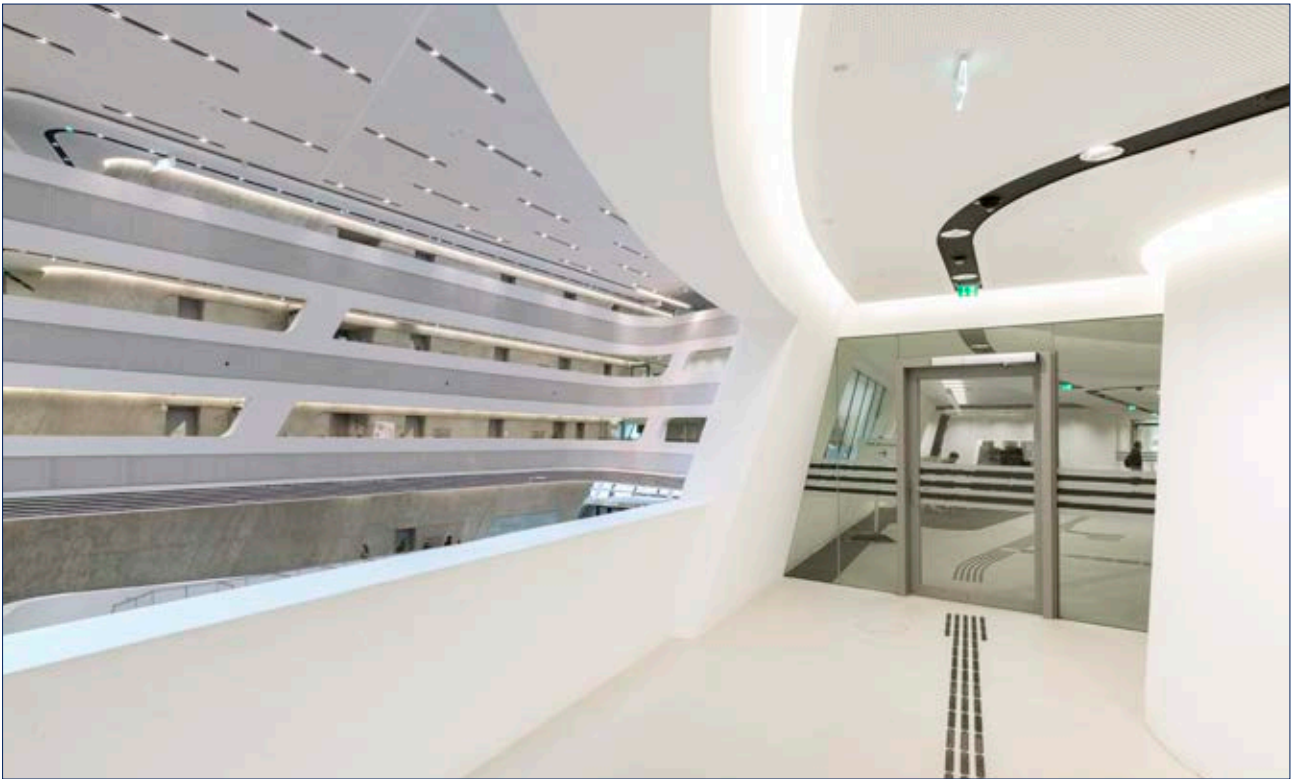

Vienna University of Economics and Business, Austria (Photo: Sigrid Rauchdobler)



Vitra Haus, Weil am Rhein, Germany (Photo: Oliver Look)



Municipal Library, Stuttgart, Germany (Photo: Lazaros Filoglou)



Danish Association for Disabled, Taastrup, Denmark (Photo: Morten Bak)

POTENTIAL APPLICATIONS OF GEZE PRODUCTS

You will find more product information in the relevant brochures, see ID numbers.

Door technology	
01	Overhead door closers ID 091593, ID 091594
02	Hold-open systems ID 091593, ID 091594
03	Integrated door closers ID 091609
04	Floor springs and all-glass fittings ID 091607
05	Sliding fitting systems and linear guides ID 123605, ID 000586
Automatic door systems	
06	Swing doors ID 144785
07	Sliding, telescopic and folding doors ID 143639
08	Curved sliding doors ID 135772
09	Revolving doors ID 132050
10	Activation devices and sensors ID 142655
Smoke and heat extraction and window technology	
11	Fanlight opening systems ID 127787
12	Electric opening and locking systems ID 127785, ID 127789
13	Electrical spindle and linear drives ID 127785, ID 127789
14	Electric chain drives ID 127785, ID 127789
15	Smoke and heat extraction systems ID 127785, ID 139075
Safety technology	
16	Emergency exit systems ID 132408
17	Access control systems ID 132158
18	Panic locks ID 132848
19	Electric strikes ID 148666
20	Building management system ID 132408
Glass systems	
21	Manual sliding wall systems (MSW) ID 104377
22	Integrated all-glass systems (IGG) ID 104366



POTENTIAL APPLICATIONS OF GEZE PRODUCTS



Door technology

The functionality, superior performance and reliability of GEZE door closers are impressive. A common design across the range, the ability to use them on all common door leaf widths and weights, and the fact that they can be individually adjusted makes their selection simple. They are continually being improved and enhanced with up-to-date features. For example, the requirements of fire protection and accessibility are fulfilled with a door closer system.

Automatic door systems

GEZE automatic door systems open up a huge variety of options in door design. The latest, innovative high-performance drive technology, safety, ease of accessibility and first class universal drive design set them apart. GEZE offers complete solutions for individual requirements. A dedicated division is responsible for the development and construction of individual special designs.

Smoke and heat extraction and window technology

GEZE smoke and heat extraction systems and ventilation technology provide complete systems solutions combining the many requirements of different types of windows. We supply a full range from energy efficient drive systems to natural ventilation and complete solutions for supplying and extracting air, also as certified SHEVs.

Safety technology

GEZE safety technology sets the standards where preventative fire protection, access control and anti-theft security in emergency exits are concerned. For each of these objectives GEZE offers tailored solutions, which combine the individual safety requirements in one intelligent system and close doors and windows in case of danger in a coordinated manner.

Building systems

In GEZE's Building Management System GEZE door, window and safety products can be integrated in to the security and control systems of the building. A central control and visualisation system monitors various automation components in the building and offers security through many different networking capabilities.

Glass systems

GEZE glass systems stand for open and transparent interior design. They can either blend discreetly into the architecture of the building or stand out as an accentuated feature. GEZE offers a wide variety of technologies for functional, reliable and aesthetic sliding wall or sliding door systems providing security with lots of design scope.

GEZE GmbH
P.O. Box 1363
71226 Leonberg
Germany

GEZE GmbH
Reinhold-Vöster-Straße 21-29
71229 Leonberg
Germany
Telefon +49 7152 203 0
Telefax +49 7152 203 310
www.geze.com

Germany
 GEZE GmbH
 Niederlassung Süd-West
 Breitwiesenstraße 8
 71229 Leonberg
 Tel. +49 7152 203 594
 Fax +49 7152 203 438
 leonberg.de@geze.com

GEZE GmbH
 Niederlassung Süd-Ost
 Parking 17
 85748 Garching bei München
 Tel. +49 7152 203 6440
 Fax +49 7152 203 77050
 muenchen.de@geze.com

GEZE GmbH
 Niederlassung Ost
 Albert-Einstein-Ring 5
 14532 Kleinmachnow bei Berlin
 Tel. +49 7152 203 6840
 Fax +49 7152 203 76849
 berlin.de@geze.com

GEZE GmbH
 Niederlassung Mitte/Luxemburg
 Adenauerallee 2
 61440 Oberursel (b. Frankfurt)
 Tel. +49 7152 203 6888
 Fax +49 7152 203 6891
 frankfurt.de@geze.com

GEZE GmbH
 Niederlassung West
 Heltorfer Straße 12
 40472 Düsseldorf
 Tel. +49 7152 203 6770
 Fax +49 7152 203 76770
 duesseldorf.de@geze.com

GEZE GmbH
 Niederlassung Nord
 Albert-Schweitzer-Ring 24-26 (3. OG)
 22045 Hamburg
 Tel. +49 7152 203 6602
 Fax +49 7152 203 76608
 hamburg.de@geze.com

GEZE Service GmbH
 Niederlassung Süd-West
 Reinhold-Vöster-Straße 25
 71229 Leonberg
 Tel. +49 1802 923392
 Fax +49 7152 9233 359
 service-leonberg.de@geze.com

GEZE Service GmbH
 Niederlassung Süd
 Parking 17
 85748 Garching bei München
 Tel. +49 1802 923392
 Fax +49 7152 9233 859
 service-muenchen.de@geze.com

GEZE Service GmbH
 Niederlassung Mitte
 Oberurseler Str. 69
 61440 Oberursel
 Tel. +49 1802 923392
 Fax +49 7152 9233 659
 service-oberursel.de@geze.com

GEZE Service GmbH
 Niederlassung West
 Heltorfer Straße 12
 40472 Düsseldorf
 Tel. +49 1802 923392
 Fax +49 7152 9233 559
 service-duesseldorf.de@geze.com

GEZE Service GmbH
 Niederlassung Ost
 Albert-Einstein-Ring 5
 14532 Kleinmachnow bei Berlin
 Tel. +49 1802 923392
 Fax +49 7152 9233 759
 service-berlin.de@geze.com

GEZE Service GmbH
 Niederlassung Nord
 Albert-Schweitzer-Ring 24-26 (3. OG)
 22045 Hamburg
 Tel. +49 1802 923392
 Fax +49 7152 9233 459
 service-hamburg.de@geze.com

Austria
 GEZE Austria
 Wiener Bundesstrasse 85
 A-5300 Hallwang
 Tel: +43 6225 87180
 Fax: +43 6225 87180 299
 austria.at@geze.com

**Baltic States –
 Lithuania / Latvia / Estonia**
 Tel. +371 678960 35
 baltic-states@geze.com

Benelux
 GEZE Benelux B.V.
 Industrieterrein Kapelbeemd
 Steenoven 36
 5626 DK Eindhoven
 Tel. +31 4026290 80
 Fax +31 4026290 85
 benelux.nl@geze.com

Bulgaria
 GEZE Bulgaria - Trade
 Representative Office
 Nickolay Haitov 34 str., fl. 1
 1172 Sofia
 Tel. +359 247043 73
 Fax +359 247062 62
 office-bulgaria@geze.com

China
 GEZE Industries (Tianjin) Co., Ltd.
 Shuangchenzhong Road
 Beichen Economic Development
 Area (BEDA)
 Tianjin 300400, P.R. China
 Tel. +86 22 26973995
 Fax +86 22 26972702
 chinasales@geze.com.cn

GEZE Industries (Tianjin) Co., Ltd.
 Branch Office Shanghai
 Jia Little Exhibition Center
 Room C 2-102
 Shenzhuan Rd. 6000
 201619 Shanghai, P.R. China
 Tel. +86 21 52340960
 Fax +86 21 64472007
 chinasales@geze.com.cn

GEZE Industries (Tianjin) Co., Ltd.
 Branch Office Guangzhou
 Room 17 C 3
 Everbright Bank Building, No.689
 Tian He Bei Road
 510630 Guangzhou, P.R. China
 Tel. +86 20 38731842
 Fax +86 20 38731834
 chinasales@geze.com.cn

GEZE Industries (Tianjin) Co., Ltd
 Branch Office Beijing
 Room 04-05, 7th Floor
 Red Sandalwood Plaza
 No. 27 Jianguo Road
 Chaoyang District
 100024 Beijing, P.R.China
 Tel. +86 10 85756009
 Fax +86 10 85758079
 chinasales@geze.com.cn

France
 GEZE France S.A.R.L.
 ZAC de l'Orme Rond
 RN 19
 77170 Servon
 Tel. +33 1 606260 70
 Fax +33 1 606260 71
 france.fr@geze.com

Hungary
 GEZE Hungary Kft.
 Hungary-2051 Biatorbágy
 Vendel Park
 Huber u. 1.
 Tel. +36 23532 735
 Fax +36 23532 738
 office-hungary@geze.com

Iberia
 GEZE Iberia S.R.L.
 C/ Andorra 24
 08830 Sant Boi de Llobregat
 (Barcelona)
 Tel. +34 902194 036
 Fax +34 902194 035
 info@geze.es

India
 GEZE India Private Ltd.
 MF 2 & 3, Guindy Industrial Estate
 Ekkattuthangal
 Chennai 600 097
 Tamilnadu
 Tel. +91 44 406169 00
 Fax +91 44 406169 01
 office-india@geze.com

Italy
 GEZE Italia S.r.l
 Sede di Vimercate
 Via Fiorbellina 20
 20871 Vimercate (MB)
 Tel. +39 0399530401
 Fax+39 039 9530459/419
 italia.it@geze.com

Sede di Roma
 Via Lucrezia Romana, 91
 00178 Roma
 Tel. +39 039 9530401
 Fax +39 039 9530449
 italia.it@geze.com

Poland
 GEZE Polska Sp. z o.o.
 ul. Marywilska 24
 03-228 Warszawa
 Tel. +48 224 404 440
 Fax +48 224 404 400
 geze.pl@geze.com

Romania
 GEZE Romania S.R.L.
 IRIDE Business Park,
 Str. Dimitrie Pompeiu nr. 9-9a,
 Building 10, Level 2, Sector 2,
 020335 Bucharest
 Tel.: +40 212507 750
 Fax: +40 316201 258
 office-romania@geze.com

Russia
 OOO GEZE RUS
 Gamsonovskiy Per. 2
 115191 Moscow
 Tel. +7 495 93306 59
 Fax +7 495 93306 74
 office-russia@geze.com

Scandinavia – Sweden
 GEZE Scandinavia AB
 Mallslingan 10
 Box 7060
 18711 Täby, Sweden
 Tel. +46 87323 400
 Fax +46 87323 499
 sverige.se@geze.com

Scandinavia – Norway
 GEZE Scandinavia AB avd. Norge
 Industriveien 34 B
 2073 Dal
 Tel. +47 63957 200
 Fax +47 63957 173
 norge.se@geze.com

Scandinavia – Denmark
 GEZE Danmark
 Branch office of GEZE Scandinavia AB
 Mårkærvej 13 J-K
 2630 Taastrup
 Tel. +45 463233 24
 Fax +45 463233 26
 danmark.se@geze.com

Singapore
 GEZE (Asia Pacific) Pte. Ltd.
 21 Bukit Batok Crescent
 #23-75 Wcga Tower
 Singapore 658065
 Tel: +65 6846 1338
 Fax: +65 6846 9353
 gezesea@geze.com.sg

South Africa
 Geze South Africa (Pty) Ltd.
 GEZE, Building 3, 1019 Morkels Close
 Midrand 1685
 Tel: + 87 94337 88
 Fax: + 86 66137 52
 info@gezesa.co.za

Switzerland
 GEZE Schweiz AG
 Zeliglimatte 1A
 6260 Reiden
 Tel. +41 62 28554 00
 Fax +41 62 28554 01
 schweiz.ch@geze.com

Turkey
 GEZE Kapı ve Pencere Sistemleri
 San. ve Tic. Ltd. Sti.
 İstanbul Anadolu Yakası Organize
 Sanayi Bölgesi
 Gazi Bulvarı Caddesi 8.Sokak No:8
 Tuzla-İstanbul
 Tel. + 90 216 45543 15
 Fax + 90 216 45582 15
 office-turkey@geze.com

Ukraine
 LLC GEZE Ukraine
 ul. Viskoznaya, 17,
 Building 93-B, Office 12
 02660 Kiev
 Tel./Fax +38 445012225
 office-ukraine@geze.com

United Arab Emirates/GCC
 GEZE Middle East
 P.O. Box 17903
 Jebel Ali Free Zone
 Dubai
 Tel. +971 48833 112
 Fax +971 48833 240
 gezeme@geze.com

United Kingdom
 GEZE UK Ltd.
 Blenheim Way
 Fradley Park
 Lichfield
 Staffordshire WS13 8SY
 Tel. +44 15434430 00
 Fax +44 15434430 01
 info.uk@geze.com

GEZE REPRESENTATIVE